

# ARO Industrial Tools



**DOBCO** EQUIPMENT LTD Toll-Free 1-866-763-6226 Phone: 905-672-5557  
Fax: 905-672-5559 Email: [sales@dobcoeqp.com](mailto:sales@dobcoeqp.com)



# Table of Contents

---

<b>Industrial Air Tools Introduction</b>	1
--	---

---

## Assembly Tools

Introduction and Product Overview .....	4
Screwdrivers and Nutsetters .....	6
SE Series Screwdrivers .....	26
Pulse Nutrunners .....	32
Torque Analysis System .....	36
Screwdriver and Nutsetter Accessories .....	37
Drills and Tappers .....	40
Drill and Tapper Accessories .....	48
Impact Wrenches .....	49
Workstations and Ergonomic Accessories .....	52



## Finishing Tools

Introduction and Product Overview .....	56
Elite® Random Orbital Sanders .....	59
Elite® and Jet Vac™ Random Orbital Sanders .....	60
Elite®, Jet Vac™ and Classic Line Random Orbital Sanders .....	61
Classic Line Random Orbital, Orbital Sanders .....	62
Elite® Grinders, Sanders, Polishers .....	66
Elite® Heavy Duty Grinders .....	72
Classic Line Grinders, Sanders, Polishers .....	76
Finishing Tool Accessories .....	84



## Special Purpose Tools

Introduction and Product Overview .....	86
Marking Pens .....	88
Peening and Scaling Hammer .....	88
Laminate Trimmer .....	88
Portable Electrode Dressers .....	89



## General Accessories

Tune-up and Service Kits .....	95
Ergonomic Accessories .....	96
Warranty Information .....	101
Index and Quick Reference .....	102
Warning Information .....	104
Contact Information .....	105

# ARO Industrial Tools



“The fastening requirements on this assembly have changed. I need tools that will help us meet the spec consistently.”

“We’re considering full vacuum operation in our sanding areas to improve our results. Can you make a recommendation?”

“We’re redesigning one of our production departments to improve ergonomics. We need some help in selecting proper tools and accessories.”

New requirements. New processes. New demands and desires for a more efficient, more comfortable workplace. New problems confront decision makers in industrial production and maintenance everyday. ARO provides solutions that blend solid expertise with tools designed to simply do the job better than any competitive offering. ARO people and products are problem solvers working for you.

This catalog reflects a stronger, more focused organization and product line, backed by investments in the latest manufacturing systems, tool designs, and materials. You’ll find the highly regarded Series 20/50 screwdrivers, nutsetters, drills, and of pulse nutrunners, along with many other products that complete the Assembly Tools line. More than half the models in the Finishing Tools line are new or recent introductions, underscoring ARO’s commitment to this function. And the Special Purpose Tools section is the best example of ARO’s unique dedication to meeting specific customer needs.

ARO Series 20/50 drills combine power and speed with operator comfort.



# ARO Industrial Tools

Throughout the Finishing Tools section, you'll note the expansion of the Elite® Series products, now including new random orbital sanders and heavy duty grinders, sanders, and polishers. The Elite Series products define the highest level of advancement in finishing tools, utilizing new materials such as lightweight composites, ergonomic design for enhanced operator comfort, and the ultimate in power and performance.

The Classic Line represents the most popular models from ARO's established range of tools, reflecting more traditional design and materials. All Classic Line models carry a well-earned reputation for performance and durability, and many have pioneered ergonomic design trends through size, weight, and housing configurations. They're the best of the tools that helped build the ARO reputation.

Throughout the catalog, you'll find details on the features that distinguish ARO tools every day in production sites around the world: the exceptionally fast shut-off action of the ASO clutch in many ARO assembly tools delivers superior accuracy and repeatability, while minimizing operator exposure to torque reaction. High speed, light weight, and variable grip sizes to suit different operators are just some of the hallmarks of the new Elite Series composite random orbital sanders. The new Elite Series heavy duty grinders have the power to tackle heavy material removal while protecting operators, with a patented motor controller and adjustable guards. There's much more.

ARO workstations, combined with proper tool selection, help achieve neutral hand/arm positions and minimal grip force for repetitive operations. They also help maximize tool performance and create a cleaner, more efficient workplace. Tool features and accessories such as workstations are just the beginning of the ARO ergonomics portfolio. Your ARO distributor or representative can provide a wealth of information, including our HPE (High Performance Ergonomics) Solutions capabilities brochure (Form No. 52881).

If your needs extend beyond the portable tools addressed in this catalog, check into ARO Custom Tools – modified versions of standard products that meet specific assembly or finishing requirements. ARO Air Hoists are compact, powerful, and reliable – even in the most demanding material handling applications. ARO Automatic Machining Tools provide high precision, low cost solutions for secondary machining operations, in pneumatic and electric/pneumatic models. And refer to the IRAX Accessories catalog for a complete selection of quality air tool and air line accessories, in addition to those covered here. Consult your ARO distributor or representative for more details and separate catalogs on these products.



Classic Line tools have helped establish the ARO reputation for solid durability.



Elite Series tools incorporate the latest in ergonomic design, new materials, and efficient performance.



Impact Wrenches, Workstations, Special Purpose and Custom Tools exemplify ARO's ability to meet individual customer needs.



# High Performance Ergonomics

User-oriented design with a difference you can measure. What distinguishes an ergonomically correct or enhanced tool from a pretender? How can you recognize form and function rather than mere cosmetics? Ingersoll-Rand has translated the linkage of tool, task, and tool user into a quantifiable factor of productivity improvement – a concept called High Performance Ergonomics. It means more than just bringing performance and ergonomics together. It means bringing them to a whole new level.



## High Performance Ergonomics

IR offers ETC's objective ergonomics evaluation, training, and consulting services to customers, as one aspect of our High Performance Ergonomics Solutions initiative. It can be as simple and specific as a workplace evaluation or custom training module. Or as extensive as an assembly process redesign. And IR can offer complementary products from our growing portfolio for a comprehensive solution – including IR Zimmerman ergonomic handling systems, and more.

This focus on user-oriented design and workplace productivity is nothing new for IR. We've earned five prestigious IDEA awards for excellence in product design from the Industrial Designers Society of America and Business Week magazine, for our Cyclone finishing tools, 2131 and 2080 impact wrenches, D Series fastening tools, and now, our Q2 Series tools. This recognition is a reflection of our drive to help you improve the quality of your products and processes. And our total range of solutions – coupled with new asset management software, analysis tools, and other interface options – will help you measure the difference we can make.



## Assembly Tools



The relentless drive for improved process quality is constantly changing and advancing the requirements of assembly functions. Intense global competition and the rise of ergonomics have brought about a sharper focus on workplace productivity and the performance of every element. With one of the most extensive lines in the industry, ARO can deliver expert consultation and superior solutions in assembly tools.

The ARO Series 20 and 50 screwdrivers, nutsetters, and drills feature high efficiency air motors in compact configurations with ergonomically-correct handle designs. Their lightweight, balanced construction promotes proper working positions, helping to reduce operator fatigue and other negative effects. To match the requirements of any task, ARO offers a complete selection of pistol-grip, straight and 90° angle models — plus 45° angle drills — to allow for appropriate hand/arm positioning relative to the fastening angle.

For assembly tasks involving threaded fasteners, the ARO Series 20 and 50 screwdrivers and nutsetters offer unbeatable torque capability with fast automatic shut-off features. They deliver repeatable torque accuracy time after time, independent of individual operator — and variable joint — characteristics. To increase operator productivity, ARO offers several trigger options on assembly tools — push-to-start, lever permit, trigger permit, trigger start, and quick-reverse trigger.

The ARO Series 20 and 50 drills offer the most comprehensive selection of speeds available. A wide variety of spindle options and menu-driven selection systems allow you to customize tools for specific application requirements.

The ARO Model 7672-A18 Woodworking Screwdriver — one of our most popular models — is designed specifically for jobs that require wood screw fastening. Developed to deliver speed and power, the “Wooddriver” provides quick, smooth rundown in even the toughest hardwoods. And, it’s equipped with value-added features that give you more tooling for your investment.

**Screwdrivers and Nutsetters** ..... Pgs. 6 – 31

Choose from an extensive range of configurations and clutch types, all designed to achieve precise results. The ARO line includes quiet, convenient DC electric models as well.

**Pulse Nutrunners** ..... Pgs. 32 – 39

ARO Pulse and Pulse Plus Nutrunners meet the demands of assembly operations with the high speed rundown of fasteners, exceptional accuracy and consistency in torque delivery, and operator oriented design.

**Drills** ..... Pgs. 40 – 48

High-efficiency motors deliver increased speed and power for faster, smoother drilling. Compact ergonomic design promotes operator comfort and productivity.

**Impact Wrenches** ..... Pgs. 49 – 51

Durable, powerful, and easy to handle, ARO impact wrenches are ideal for many assembly, maintenance, and service operations.

**Workstations** ..... Pgs. 52 – 55

ARO workstations deliver practical benefits with proper ergonomic positioning and a clean, uncluttered workspace.

To be sure that your assembly tools are achieving consistent results, the ETT (Expert Torque Tester) series is the ideal quality control companion for assembly operations with stringent torque control standards. It features exceptional accuracy in a portable size to provide a convenient method for measuring and calibrating the torque output at the job site.

To meet the needs of the operators who use them, ARO is dedicated to producing tools that provide a comfortable work environment. By developing smaller, lighter, and quieter products, the ARO designs offer higher levels of comfort, safety, and reliability.

The ARO "Woodriver" is an economical solution for wood screw fastening requirements.





# Screwdriver Selection

## Screwdrivers and Nutsetters



Phone: 905-672-5557  
 sales@dobcoeqp.com

### Screwdriver Selection

When selecting a production screwdriver, it is important to take into account the following considerations:

- A Type of Joint:**  
 First, consider the type of joint you will be working with. Since joints vary according to the type of screw and fastening involved, you should always verify the type of screw and material you'll be working with.
- B Torque Requirements:**  
 Next, you should take into account the amount of torque needed for your production requirements. Screwdriver type, length, and the type of steel it's made of all effect torque requirements.
- C Clutch Options:**  
 Finally, production screwdrivers come with four different clutch options. Selection of the proper clutch depends on the type of joints, screws used, and torque required in production.

Use these easy steps to determine which ARO production screwdriver best meets your specific production requirements.

### A - Types of Joints

When choosing a production screwdriver, always take the type of joint and screws you'll be working with into account. This information will also help you determine torque and clutch requirements.

#### Fastening Applications

Clutch Options	Free-Running Sudden-Stop	Soft Pull-Up	Self-Tapping in Thick Material	Sheet Metal Screws	Lock Nuts	Wood Screws
<b>Automatic Shutoff</b>	Excellent for all size screws.		Not suitable if tapping torque exceeds stripping	Good for all size screws. torque or clutch setting.	Excellent for all size screws.	
<b>Adjustable Ball</b>	Good for all size screws where close torque control is not required.	Good for most screws where close torque control is not required.	Good for most screws. With proper operator technique can be used where tapping torque exceeds stripping torque.	Good for most screws. With proper operator technique can be used where tapping torque exceeds stripping torque.	Good for most screws where close torque control is not required.	Good for all size screws.
		Slow on large screws with long heavy pull-up.	Slow on large screws.			
<b>Positive</b>		Good for small to medium size screws.	Good for most screws where stripping torque is considerably higher than tapping torque.	Good for all size screws where stripping torque is considerably higher than tapping torque.	Fair for all size screws.	Excellent for all size screws.
		Requires considerable operator pressure on large screws.	Excellent in non-uniform or misaligned material.	Excellent when sheets are frequently misaligned.		
<b>Direct Drive</b>		Good for large and medium size screws. Must be adjusted to run rather slowly for small screws.	Not recommended unless stripping torque is considerably higher than tapping torque.	Not recommended unless stripping torque is considerably higher than tapping torque.	Good for large and medium screws. Must be adjusted to run rather slowly for small screws.	Excellent for large and medium screws. Must be adjusted to run rather slowly for small screws.



# Screw Torque Guide

## Screwdrivers and Nutsetters

### B - Screw Torque Guide<sup>1</sup>

Screw Size	Low Carbon Steel		18-8 Stainless		Brass		Silicon Bronze		Aluminum 2024-T4		316 Stainless		Monel	
	in.-lb	Nm	in.-lb	Nm	in.-lb	Nm	in.-lb	Nm	in.-lb	Nm	in.-lb	Nm	in.-lb	Nm
2-56	2.2	.25	2.5	.28	2.0	.23	2.3	.26	1.4	.16	2.6	.29	2.5	.28
2-64	2.7	.31	3.0	.34	2.5	.28	2.8	.32	1.7	.19	3.2	.26	3.1	.35
3-48	3.5	.40	3.9	.44	3.2	.36	3.6	.41	2.1	.24	4.0	.45	4.0	.45
3-56	4.0	.45	4.4	.50	3.6	.41	4.1	.46	2.4	.27	4.6	.52	4.5	.51
4-40	4.7	.53	5.2	.59	4.3	.49	4.8	.54	2.9	.33	5.5	.62	5.3	.60
4-48	5.9	.67	6.6	.75	5.4	.61	6.1	.69	3.6	.41	6.9	.78	6.7	.76
5-40	6.9	.78	7.7	.87	6.3	.71	7.1	.80	4.2	.48	8.1	.92	7.8	.88
5-44	8.5	.96	9.4	1.06	7.7	.87	8.7	.98	5.1	.58	9.8	1.11	9.6	1.09
6-32	8.7	.98	9.6	1.09	7.9	.89	8.9	1.01	5.3	.60	10.1	1.14	9.8	1.11
6-40	10.9	1.23	12.1	1.37	9.9	1.12	11.2	1.27	6.6	.75	12.7	1.44	12.3	1.39
8-32	17.8	2.01	19.8	2.24	16.2	1.83	18.4	2.08	10.8	1.22	20.7	2.34	20.2	2.28
8-36	19.8	2.24	22.0	2.49	18.2	2.01	20.4	2.31	12.0	1.36	23.0	2.60	22.4	2.53
10-24	20.9	2.35	22.8	2.58	18.6	2.10	21.2	2.40	13.8	1.59	23.8	2.69	25.9	2.93
10-32	29.7	3.36	31.7	3.58	25.9	2.93	29.3	3.31	19.2	2.17	33.1	3.74	34.9	3.94
1/4-20	65.0	7.35	75.2	8.50	61.5	6.95	68.8	7.77	45.6	5.15	78.8	8.90	85.3	9.64
1/4-28	90.0	10.20	90.0	10.20	77.0	8.70	87.0	9.83	57.0	6.44	99.0	11.20	106.0	12.00
5/16-18	129.0	14.60	132.0	14.90	107.0	12.10	123.0	13.90	80.0	9.04	138.0	15.60	149.0	16.80
5/16-24	139.0	15.70	142.0	16.10	116.0	13.10	131.0	14.80	86.0	9.72	147.0	16.60	160.0	18.10

(1) Screw types and materials affect the amount of torque needed for a given production job. Use this table to determine your specific needs. Source: "Fasteners" published by Industrial Fasteners Institute.

### C - Clutch Selection



**Direct Drive** – Good for non-precision fastening in wood, aluminum, and soft draw applications. Torque output is determined only by the stall torque of the motor at a given air pressure.



**Positive Clutch** – Good general purpose clutch for soft draw applications in wood and aluminum. Allows motor to run without bit turning until pressure is applied to the spindle to engage jaws. Clutch with angle jaws ratchets as fastener resistance overcomes operator pressure on the driver. Torque output is determined by the force applied by the operator and the ratchet time. Clutch with 90° jaws acts as a direct drive when jaws are engaged and stalls motor as fastener resistance builds.



**Adjustable Ball Clutch** – Excellent general purpose clutch; provides good torque control for most assembly line applications. Allows motor to run without bit turning until pressure is applied to the spindle to engage the 90° jaws. As fastener resistance overcomes spring force, balls are displaced which causes the clutch to ratchet. Torque output is determined by adjusting the clutch spring force.



**Automatic Shut-Off Clutch** – Best clutch for all threaded fasteners and where controlled fastening is required. Motor is actuated and bit rotates when pressure is applied to the spindle which opens the throttle. When pre-set torque is achieved, the throttle is automatically closed and the tool stops. Torque output is determined by adjusting the clutch spring force.

Check your torque requirements and the types of materials and screw being used to determine which clutch best suits your needs.

# Torque Conversion Table

## Screwdrivers and Nutsetters

Torque Conversion Table

in.-lbs	ft.-lbs	Nm	in.-lbs	ft.-lbs	Nm	in.-lbs	ft.-lbs	Nm	in.-lbs	ft.-lbs	Nm
1	.08	.11	27	2.25	3.05	54	4.50	6.10	80	6.66	9.04
2	.17	.23	28	2.33	3.16	55	4.58	6.21	81	6.75	9.15
3	.25	.34	29	2.42	3.28	56	4.68	6.33	82	6.83	9.27
4	.33	.45	30	2.50	3.39	57	4.75	6.44	83	6.92	9.38
5	.42	.57	31	2.58	3.50	58	4.83	6.55	84	7.00	9.49
6	.50	.68	32	2.67	3.62	59	4.92	6.67	85	7.08	9.61
7	.58	.80	33	2.75	3.73	60	5.00	6.78	86	7.16	9.72
8	.66	.90	34	2.83	3.84	61	5.08	6.89	87	7.25	9.83
9	.75	1.02	36	3.00	4.07	62	5.16	7.01	88	7.33	9.94
10	.83	1.13	37	3.08	4.18	63	5.25	7.12	89	7.42	10.06
11	.92	1.24	38	3.16	4.29	64	5.33	7.23	90	7.50	10.17
12	1.00	1.35	39	3.25	4.41	65	5.42	7.35	91	7.58	10.28
13	1.08	1.47	40	3.33	4.52	66	5.50	7.46	92	7.66	10.40
14	1.16	1.58	41	3.42	4.63	67	5.58	7.57	93	7.75	10.51
15	1.25	1.70	42	3.50	4.75	68	5.66	7.68	94	7.83	10.62
16	1.33	1.81	43	3.58	4.86	69	5.75	7.80	95	7.92	10.74
17	1.42	1.92	44	3.66	4.97	70	5.83	7.91	96	8.00	10.85
18	1.50	2.03	45	3.75	5.09	71	5.92	8.02	97	8.08	10.96
19	1.58	2.15	46	3.83	5.20	72	6.00	8.14	98	8.16	11.07
20	1.66	2.26	47	3.92	5.31	73	6.08	8.25	99	8.25	11.19
21	1.75	2.37	48	4.00	5.42	74	6.14	8.36	100	8.33	11.30
22	1.83	2.49	49	4.08	5.54	75	6.25	8.48	108	9.00	12.20
23	1.92	2.60	50	4.16	5.65	76	6.33	8.59	120	10.00	13.50
24	2.00	2.71	51	4.25	5.76	77	6.42	8.70	132	11.00	14.90
25	2.08	2.83	52	4.33	5.88	78	6.50	8.81			
26	2.16	2.94	53	4.42	5.99	79	6.58	8.93			

Inch Pounds x 0.113 = Newton Meters  
 Newton Meters x 8.849 = Inch Pounds  
 Foot Pounds x 1.356 = Newton Meters  
 Newton Meters x 0.737 = Foot Pounds

### Model Identification Guide

Example: SA024C-26-Q

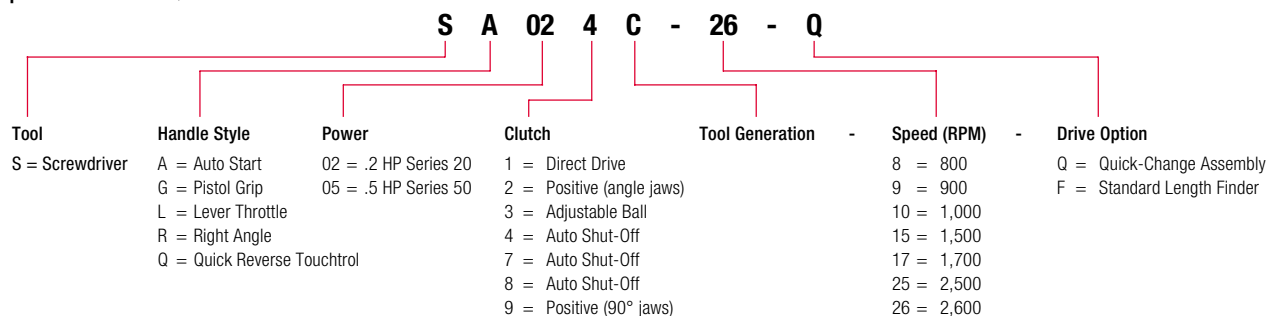

Toll-Free 1-866-763-6226 Phone: 905-672-5557  
 Fax: 905-672-5559 Email: sales@dobcoeqp.com

# Quick Reverse (QRT) Models Screwdrivers and Nutsetters

**Torque Output: 3 to 100 in.-lbs (0.34 to 11.3 Nm)**

## Ordering Information

Tools are equipped with a Quick-Change Assembly (-Q Drive Option) as standard. To order a tool equipped with a (FINDER) option, specify the following option:

- Standard Length Finder.**

Change the "-Q" in the model number to "-F" and specify one of the FINDER KITS listed in the chart below.

**Note:** Apex Magnetic Bit Holder (40259), and Magna Magnetic Bit Holder (36585) may be ordered separately.

**Example: SQ024C-9-A Drive Option.**

Finder Kit	Screw Size		Bit to Use Order Separately
	Flat head	Round head	
46343-1	1	2	F164
46343-2	2	3	F1645
46343-3	3	4	XF165
46343-4	4	5	XF166
46343-5	5	6	XF167
46343-6	6	8	XF168
46343-8	8	10	XF169
46343-10	10	12	XF1610

**Note:** Tools ordered with the **Finder Option** will not accommodate the "-Q", options. Consult factory.



Quick-Change Assembly (Q)

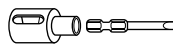

Standard Length Finder (F)

## QRT Screwdrivers

**800 to 2600 RPM**

- Exclusive ARO Quick-Reverse Touchtrol™ trigger enables instant, single-hand control of spindle rotation and speed.
- Ideal for applications in which reversing or fastener realignment occurs frequently.
- Ergonomically-correct handle design and well-balanced construction provide comfortable handling and reduce operator fatigue.
- Wide selection of speeds and torque outputs ensures the proper tool for the assembly conditions.

## Standard Equipment

- 1/4" Hex Bit Holder
- Quick-Change Chuck on Direct Drive Models
- Quick-Change Assembly on Series 20 and 50 Models



## Automatic Shut-Off Screwdrivers

Model No.	Free Speed rpm	Torque Range-Soft Draw						Tool Length		Spindle Offset		Tool Weight		@ Free Speed		
		Spring		Spring		Spring		in.	mm	in.	mm	lbs	kg	Air Cons.	Sound Level	
		in.-lbs	Nm	in.-lbs	Nm	in.-lbs	Nm						cfm	L/s	dB(A)	
<b>Series 20</b>		<b>Brown</b>		<b>Green</b>		<b>Red</b>										
<b>Trigger Permit<sup>1</sup></b>																
SQ024C-26-Q	2,600	-	-	-	-	3-10	.34-1.1	7.1	180	.75	19	1.9	.8	15	7	79
SQ024C-15-Q	1,500	-	-	8-20	.9-2.3	3-10	.34-1.1	7.5	191	.75	19	2.0	.9	15	7	79
SQ024C-9-Q	900	10-30	1.1-3.4	8-20	9-2.3	3-10	.34-1.1	7.5	191	.75	19	2.0	.9	15	7	79
SQ024C-8-Q	800	12-40	1.4-4.5	10-26	1.1-2.9	4-13	.50-1.5	7.5	191	.75	19	2.0	.9	15	7	79
<b>Series 50</b>		<b>Yellow</b>		<b>Brown</b>		<b>Green</b>										
<b>Trigger Permit<sup>1</sup></b>																
SQ054C-24-Q	2,400	-	-	-	-	15-40	1.7-4.5	8.3	211	.94	24	3.0	1.3	25	12	78
SQ054C-16-Q	1,600	-	-	25-60	2.8-6.8	15-40	1.7-4.5	8.8	224	.94	24	3.2	1.4	25	12	78
SQ054C-10-Q	1,000	35-80	4.0-9.0	25-60	2.8-6.8	15-40	1.7-4.5	8.8	224	.94	24	3.2	1.4	25	12	78
SQ054C-8-Q	800	35-100	4.0-11.3	25-60	2.8-6.8	15-40	1.7-4.5	8.8	224	.94	24	3.2	1.4	25	12	78

Air Inlet – 1/4" NPTF

Recommended Air Pressure – 90 PSI (6.2 bar)

Recommended Hose Size – 5/16" (8mm) I.D.

**Note:** The torque values shown for a given model indicate the clutch spring(s) included with the tool. The torque value in bold type indicates the standard spring equipped in the clutch.

(1) Series 20 and 50 QRT Screwdrivers feature a push-to-start throttle mechanism with a trigger permit for forward rotation. The reverse trigger position provides instant full-power reverse rotation.



**Toll-Free 1-866-763-6226 Phone: 905-672-5557**  
**Fax: 905-672-5559 Email: sales@dobcoeqp.com**



Quick Reverse (QRT) Models

# Screwdrivers and Nutsetters

**Torque Output: 15 to 110 in.-lbs (1.7 to 12.5 Nm)**

**Performance Tip:**

Check the tolerance in your work pieces. Misaligned parts may lead to a loss of power and torque. Be sure to check the dimensions and alignment of any pre-drilled or punched holes, as well as the dimensions of the screws being used.



8515-APR-P

Model No.	Free Speed rpm	Clutch Type	Stall Torque		Torque Range		Tool Length		Spindle Offset		Tool Weight		@ Free Speed		
			in.-lbs	Nm	Soft Draw	in.-lbs	Nm	in.	mm	in.	mm	lbs	kg	Air Consp. cfm	L/s
<b>000 Series</b>															
8684-BPR-D	2300	Direct Drive	15	1.7	-	-	4.8	123	.8	20	1.3	.6	23	10.8	82
8683-BPR-D	750	Direct Drive	50	5.7	-	-	6.0	152	.8	20	1.6	.7	17	8.0	82
8684-BPR-P	2300	Positive	15 <sup>2</sup>	1.7	-	-	6.3	160	.8	20	1.7	.8	23	10.8	82
8683-BPR-P	750	Positive	50 <sup>2</sup>	5.7	-	-	7.1	179	.8	20	2.0	.9	17	8.0	82
8684-BPR-(1)	2300	Adj. Ball	-	-	3-16	.3-1.8	7.0	178	.8	20	1.8	.8	23	10.8	82
8683-BPR-(1)	750	Adj. Ball	-	-	3-20	.3-2.3	8.1	206	.8	20	2.1	.9	17	8.0	82
<b>0 Series</b>															
8521-BPR-D	2100	Direct Drive	45	5.1	-	-	6.8	173	.9	23	2.2	1.0	27	12.7	82
• 8515-BPR-D	1500	Direct Drive	50	5.7	-	-	8.2	208	.9	23	2.8	1.3	27	12.7	82
8509-BPR-D	900	Direct Drive	80	9.1	-	-	8.2	208	.9	23	2.8	1.3	26	12.2	82
• 8506-BPR-D	600	Direct Drive	110	12.5	-	-	8.2	208	.9	23	2.8	1.3	24	11.3	82
8521-APR-P	2100	Positive	45 <sup>2</sup>	5.1	-	-	6.8	173	.9	23	2.2	1.0	27	12.7	82
8515-APR-P	1500	Positive	50 <sup>2</sup>	5.7	-	-	8.2	208	.9	23	2.9	1.3	27	12.7	82
8509-APR-P	900	Positive	80 <sup>2</sup>	9.1	-	-	8.2	208	.9	23	2.9	1.3	26	12.2	82
8506-APR-P	600	Positive	110 <sup>2</sup>	12.5	-	-	8.2	208	.9	23	2.9	1.3	24	11.3	82
8521-APR-A	2100	Adj. Ball	-	-	8-40	.9-4.5	7.5	190	.9	23	2.5	1.1	27	12.7	82
8515-APR-A	1500	Adj. Ball	-	-	8-45	.9-5.1	7.5	190	.9	23	2.5	1.1	27	12.7	82
8509-APR-A	900	Adj. Ball	-	-	8-50	.9-5.7	8.9	226	.9	23	3.1	1.4	26	12.2	82
8506-APR-A	600	Adj. Ball	-	-	8-70	.9-7.9	8.9	226	.9	23	3.1	1.4	24	11.3	82

• Most popular model.

Air Inlet – 1/4" NPTF

Recommended Air Pressure – 90 PSI (6.2 bar)

Recommended Hose Size – 5/16" (8mm) I.D.

(1) Add -A for internal adjustment clutch or -F for external clutch adjustment.

(2) Controlled by operator technique.

Note: The torque values shown for a given model indicate the clutch spring(s) included with the tool.



Toll-Free 1-866-763-6226 Phone: 905-672-5557

Fax: 905-672-5559 Email: sales@dobcoeqp.com

# Screwdrivers and Nutsetters

Torque Output: 3 to 100 in.-lbs (.34 to 11.3 Nm)



AG028A-15-Q



AG058A-10-Q

## Reversible Pistol Grip Screwdrivers

Model No.	Free Speed rpm	Torque Range-Soft Draw						Tool Length		Spindle Offset		Tool Weight		@ Free Speed		
		Spring		Spring		Spring		in.	mm	in.	mm	lbs	kg	Air Cons. cfm	Sound Level dB(A)	
		in.-lbs	Nm	in.-lbs	Nm	in.-lbs	Nm									
<b>Series 20</b>		<b>Brown</b>		<b>Green</b>		<b>Red</b>										
<b>Push-to-Start</b>																
AG024A-26-Q	2,600	-	-	-	-	3-10	.34-1.1	7.875	200	0.662	17	1.76	0.78	15	7	76
AG024A-15-Q	1,500	-	-	8-20	.9-2.3	3-10	.34-1.1	8.250	210	0.662	17	1.86	0.85	15	7	76
AG024A-9-Q	900	10-30	1.1-3.4	8-20	.9-2.3	3-10	.34-1.1	8.250	210	0.662	17	1.86	0.85	15	7	76
AG024A-8-Q	800	12-40	1.4-4.5	10-26	1.1-2.9	4-13	.5-1.5	8.250	210	0.662	17	1.86	0.85	15	7	76
<b>Trigger Start</b>																
AG027A-26-Q	2,600	-	-	-	-	3-10	.34-1.1	7.875	200	0.662	17	1.76	0.78	15	7	76
AG027A-15-Q	1,500	-	-	8-20	.9-2.3	3-10	.34-1.1	8.250	210	0.662	17	1.86	0.85	15	7	76
AG027A-9-Q	900	10-30	1.1-3.4	8-20	.9-2.3	3-10	.34-1.1	8.250	210	0.662	17	1.86	0.85	15	7	76
AG027A-8-Q	800	12-40	1.4-4.5	10-26	1.1-2.9	4-13	.5-1.5	8.250	210	0.662	17	1.86	0.85	15	7	76
<b>Trigger Permit</b>																
AG028A-26-Q	2,600	-	-	-	-	3-10	.34-1.1	7.875	200	0.662	17	1.76	0.78	15	7	76
AG028A-15-Q	1,500	-	-	8-20	.9-2.3	3-10	.34-1.1	8.250	210	0.662	17	1.86	0.85	15	7	76
AG028A-9-Q	900	10-30	1.1-3.4	8-20	.9-2.3	3-10	.34-1.1	8.250	210	0.662	17	1.86	0.85	15	7	76
AG028A-8-Q	800	12-40	1.4-4.5	10-26	1.1-2.9	4-13	.5-1.5	8.250	210	0.662	17	1.86	0.85	15	7	76
<b>Series 50</b>		<b>Yellow</b>		<b>Brown</b>		<b>Green</b>										
<b>Push-to-Start</b>																
AG054A-24-Q	2,400	-	-	-	-	15-40	1.7-4.5	8.375	212	0.865	22	2.70	1.20	25	12	80
AG054A-16-Q	1,600	-	-	25-60	2.8-6.8	15-40	1.7-4.5	8.875	225	0.865	22	2.90	1.29	25	12	80
AG054A-10-Q	1,000	35-80	4.0-9.0	25-60	2.8-6.8	15-40	1.7-4.5	8.875	225	0.865	22	2.90	1.29	25	12	80
AG054A-8-Q	800	35-100	4.0-11.3	25-60	2.8-6.8	15-40	1.7-4.5	8.875	225	0.865	22	2.90	1.29	25	12	80
<b>Trigger Start</b>																
AG057A-24-Q	2,400	-	-	-	-	15-40	1.7-4.5	8.375	212	0.865	22	2.70	1.20	25	12	80
AG057A-16-Q	1,600	-	-	25-60	2.8-6.8	15-40	1.7-4.5	8.875	225	0.865	22	2.90	1.29	25	12	80
AG057A-10-Q	1,000	35-80	4.0-9.0	25-60	2.8-6.8	15-40	1.7-4.5	8.875	225	0.865	22	2.90	1.29	25	12	80
AG057A-8-Q	800	35-100	4.0-11.3	25-60	2.8-6.8	15-40	1.7-4.5	8.875	225	0.865	22	2.90	1.29	25	12	80
<b>Trigger Permit</b>																
AG058A-24-Q	2,400	-	-	-	-	15-40	1.7-4.5	8.375	212	0.865	22	2.70	1.20	25	12	80
AG058A-16-Q	1,600	-	-	25-60	2.8-6.8	15-40	1.7-4.5	8.875	225	0.865	22	2.90	1.29	25	12	80
AG058A-10-Q	1,000	35-80	4.0-9.0	25-60	2.8-6.8	15-40	1.7-4.5	8.875	225	0.865	22	2.90	1.29	25	12	80
AG058A-8-Q	800	35-100	4.0-11.3	25-60	2.8-6.8	15-40	1.7-4.5	8.875	225	0.865	22	2.90	1.29	25	12	80

• Most popular model.

Air Inlet – 1/4" NPTF

Recommended Air Pressure – 90 PSI (6.2 bar)

Recommended Hose Size – 5/16" (8mm) I.D.

Note: The torque values shown for a given model indicate the clutch spring(s) included with the tool. Torque value in bold type indicates the standard spring equipped in the clutch.

# Screwdrivers and Nutsetters

**Torque Output: 3 to 100 in.-lbs (.34 to 11.3 Nm)**

## Ordering Information

Tools are equipped with a Quick-Change Assembly (-Q Drive Option) as standard. To order a tool equipped with a (FINDER) option, specify the following option at no extra cost:

- Standard Length Finder.**

Change the “-Q” in the model number to “-F” and specify one of the FINDER KITS listed in the chart at right.

**Note:** Apex Magnetic Bit Holder (40259), and Magna Magnetic Bit Holder (36585) may be ordered separately.

**Example: AS028A-15-F with 46343-4. Order bit separately.**



Quick-Change Assembly (Q)

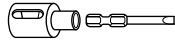

Standard Length Finder (F)

Finder Kit	Screw Size		Bit to Use Order Separately
	Flat head	Round head	
46343-1	1	2	F164
46343-2	2	3	F1645
46343-3	3	4	XF165
46343-4	4	5	XF166
46343-5	5	6	XF167
46343-6	6	8	XF168
46343-8	8	10	XF169
46343-10	10	12	XF1610

**Note:** Tools ordered with the **Finder Option** will not accommodate the “-Q”, option. Consult factory.



SA024C-9-Q



AS028A-15-Q



AS054C-10-Q

## Reversible In-Line Screwdrivers

Model No.	Free Speed rpm	Torque Range-Soft Draw						Tool Length in. mm		Spindle Offset in. mm		Tool Weight lbs kg		@ Free Speed Air Consp. Sound Level cfm L/s dB(A)		
		Spring in.-lbs Nm		Spring in.-lbs Nm		Spring in.-lbs Nm										
<b>Series 20</b>																
		<b>Brown</b>		<b>Green</b>		<b>Red</b>										
<b>Push-to-Start</b>																
SA024C-26-Q	2,600	-	-	-	-	3-10	.34-1.1	8.25	210	0.6	15	1.20	0.5	15	7	76
SA024C-15-Q	1,500	-	-	8-20	.9-2.3	3-10	.34-1.1	8.625	219	0.6	15	1.30	0.6	15	7	76
SA024C-9-Q	900	10-30	1.1-3.4	8-20	.9-2.3	3-10	.34-1.1	8.625	219	0.6	15	1.30	0.6	15	7	76
SA024C-8-Q	800	12-40	1.4-4.5	10-26	1.1-2.9	4-13	.5-1.5	8.625	219	0.6	15	1.30	0.6	15	7	76
<b>Lever Permit</b>																
AS028A-26-Q	2,600	-	-	-	-	3-10	.34-1.1	9.062	230	0.6	15.2	1.40	0.63	15	7	73.6
AS028A-15-Q	1,500	-	-	8-20	.9-2.3	3-10	.34-1.1	9.473	240	0.6	15.2	1.50	0.68	15	7	73.6
AS028A-9-Q	900	10-30	1.1-3.4	8-20	.9-2.3	3-10	.34-1.1	9.473	240	0.6	15.2	1.50	0.68	15	7	73.6
AS028A-8-Q	800	12-40	1.4-4.5	10-26	1.1-2.9	4-13	.5-1.5	9.473	240	0.6	15.2	1.50	0.68	15	7	73.6
<b>Series 50</b>																
		<b>Yellow</b>		<b>Brown</b>		<b>Green</b>										
<b>Push-to-Start</b>																
SA054C-25-Q	2,500	-	-	-	-	15-40	1.7-4.5	9.75	248	0.865	22	2.60	1.2	25	12	80
SA054C-17-Q	1,700	-	-	25-60	2.8-6.8	15-40	1.7-4.5	10.25	260	0.865	22	2.80	1.3	25	12	80
SA054C-10-Q	1,000	35-80	4.0-9.0	25-60	2.8-6.8	15-40	1.7-4.5	10.25	260	0.865	22	2.80	1.3	25	12	80
SA054C-8-Q	800	35-100	4.0-11.3	25-60	2.8-6.8	15-40	1.7-4.5	10.25	260	0.865	22	2.80	1.3	25	12	80
<b>Lever Permit</b>																
AS058A-25-Q	2,500	-	-	-	-	15-40	1.7-4.5	10.437	265	0.865	22	2.80	1.26	25	12	75.8
AS058A-17-Q	1,700	-	-	25-60	2.8-6.8	15-40	1.7-4.5	10.937	278	0.865	22	3.00	1.36	25	12	75.8
AS058A-10-Q	1,000	35-80	4.0-9.0	25-60	2.8-6.8	15-40	1.7-4.5	10.937	278	0.865	22	3.00	1.36	25	12	75.8
AS058A-8-Q	800	35-100	4.0-11.3	25-60	2.8-6.8	15-40	1.7-4.5	10.937	278	0.865	22	3.00	1.36	25	12	75.8

• Most popular model.

Air Inlet – 1/4" NPTF

Recommended Air Pressure – 90 PSI (6.2 bar)

Recommended Hose Size – 9/16" (8mm) I.D.

**Note:** The torque values shown for a given model indicate the clutch spring(s) included with the tool. Torque value in bold type indicates the standard spring equipped in the clutch.



**Toll-Free 1-866-763-6226 Phone: 905-672-5557**

**Fax: 905-672-5559 Email: sales@dobcoeqp.com**



# Screwdrivers and Nutsetters

**Torque Output: 3 to 130 in.-lbs (.30 to 14.7 Nm)**

## Ordering Information

Specify the Base Model Number for the tool with the desired free speed and torque range from the charts below. Add the appropriate Dash No. / Letter to indicate one of the following Drive Options:

- **1/4" Square Drive.**  
Add "-1" to the end of the base model number. Not available on Models AR058A-6H-().
- **3/8" Square Drive.**  
Add "-2" to the end of the base model number. Not available on Models AR028A-()L-().
- **1/4" Female Hex Bit Holder.**  
Add "-H" to the end of the base model number.
- **Standard Length Finder.**  
Add "-F" to the end of the base model number and Not available on Models AR028A-()L-().

**Example: AR028A-48L-1**

### Right Angle Heads available:

- "L" – Light Duty (aircraft head)
- "R" – Regular Duty
- "H" – Heavy Duty



AR028A-14L-H

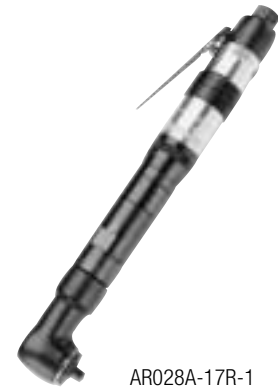

AR028A-17R-1



AR058A-16R-2



AR058A-16R-1

## Reversible Right Angle Screwdrivers and Nutsetters

Model No.	Free Speed rpm	Torque Range-Soft Draw						Tool Length		Spindle Offset		Tool Weight		@ Free Speed		
		Spring		Spring		Spring		in.	mm	in.	mm	lbs	kg	Air Consp. cfm	Sound Level L/s dB(A)	
<b>Series 20</b>		<b>Brown</b>		<b>Green</b>		<b>Red</b>										
<b>Lever Throttle</b>																
AR028A-48L-()	4,800	-	-	-	-	3-7	.30-.80	12.9	328	0.33	8.3	2.20	1.0	15	7	76
AR028A-25L-()	2,500	-	-	-	-	5-10	.60-1.1	12.9	328	0.33	8.3	2.20	1.0	15	7	76
AR028A-14L-()	1,425	-	-	8-20	.9-2.3	5-10	.60-1.1	13.3	338	0.33	8.3	2.30	1.0	15	7	76
AR028A-9L-()	875	10-30	1.1-3.4	8-20	.9-2.3	5-10	.60-1.1	13.3	338	0.33	8.3	2.30	1.0	15	7	76
AR028A-17R-()	1,750	-	-	-	-	7-16	.80-1.8	11.9	302	0.58	14.8	2.21	1.0	15	7	76
AR028A-10R-()	1,000	-	-	10-26	1.1-2.9	7-16	.80-1.8	11.9	302	0.58	14.8	2.30	1.0	15	7	76
AR028A-5R-()	500	15-40	1.7-4.5	10-26	1.1-2.9	7-16	.80-1.8	12.4	315	0.58	14.8	2.30	1.0	15	7	76
<b>Series 50</b>		<b>Yellow</b>		<b>Brown</b>		<b>Green</b>										
<b>Lever Throttle</b>																
AR058A-24R-()	2,400	-	-	-	-	20-40	2.2-4.5	13.5	343	0.58	14.7	3.60	1.6	25	12	80
AR058A-16R-()	1,650	-	-	-	-	25-58	2.8-6.5	13.5	343	0.58	14.7	3.60	1.6	25	12	80
AR058A-9R-()	950	-	-	25-90	2.8-10.2	25-58	2.8-6.5	14.0	356	0.58	14.7	3.80	1.7	25	12	80
AR058A-6H-()	600	35-130	4.0-14.7	23-81	2.6-9.2	23-52	2.6-5.9	14.2	360	0.65	16.5	4.00	1.8	25	12	80

Air Inlet – 1/4" NPTF

Recommended Air Pressure – 90 PSI (6.2 bar)

Recommended Hose Size – 5/16" (8mm) I.D.

Note: The torque values shown for a given model indicate the clutch spring(s) included with the tool. The torque value in bold type indicates the standard spring equipped in the clutch.



**Toll-Free 1-866-763-6226 Phone: 905-672-5557**  
**Fax: 905-672-5559 Email: sales@dobcoeqp.com**

# Screwdrivers and Nutsetters

Torque Output: 4 to 100 in.-lbs (.5 to 11.3 Nm)



SG023B-15-Q



SG053B-17-Q

## Reversible Pistol Grip Screwdrivers

Model No.	Free Speed rpm	Torque Range-Soft Draw						Tool Length		Spindle Offset		Tool Weight		@ Free Speed		
		Spring in.-lbs	Spring Nm	Spring in.-lbs	Spring Nm	Spring in.-lbs	Spring Nm	in.	mm	in.	mm	lbs	kg	Air Cons. cfm	Sound Level L/s dB(A)	
<b>Series 20</b>		Blue		Yellow		-										
<b>Trigger Start</b>																
SG023B-26-Q	2,600	-	-	4-12	.5-1.4	-	-	6.6	169	.66	17	1.7	.8	15	7	76
• SG023B-15-Q	1,500	-	-	4-20	.5-2.3	-	-	7.0	178	.66	17	1.8	.8	15	7	76
• SG023B-9-Q	900	20-30	2.3-3.4	4-20	.5-2.3	-	-	7.0	178	.66	17	1.8	.8	15	7	76
<b>Series 50</b>		Gray		Blue		Yellow										
<b>Trigger Start</b>																
SG053B-25-Q	2,500	-	-	-	-	10-40	1.1-4.5	8.9	226	.80	21	2.9	1.4	25	12	78
• SG053B-17-Q	1,700	-	-	15-60	1.7-6.8	10-40	1.1-4.5	9.4	238	.80	21	3.1	1.5	25	12	78
• SG053B-10-Q	1,000	-	-	15-80	1.7-9.0	10-40	1.1-4.5	9.4	238	.80	21	3.1	1.5	25	12	78
SG053B-8-Q*	800	45-100	5.1-11.3	15-80	1.7-9.0	10-40	1.1-4.5	9.4	238	.80	21	3.1	1.5	25	12	78

\* Most popular model.

Air Inlet – 1/4" NPTF

Recommended Air Pressure – 90 PSI (6.2 bar)

Recommended Hose Size – 5/16" (8mm)

Note: The torque values shown for a given model indicate the clutch spring(s) included with the tool. The torque value in bold type indicates the standard spring equipped in the clutch.

# Screwdrivers and Nutsetters

**Torque Output: 4 to 100 in.-lbs (.5 to 11.3 Nm)**

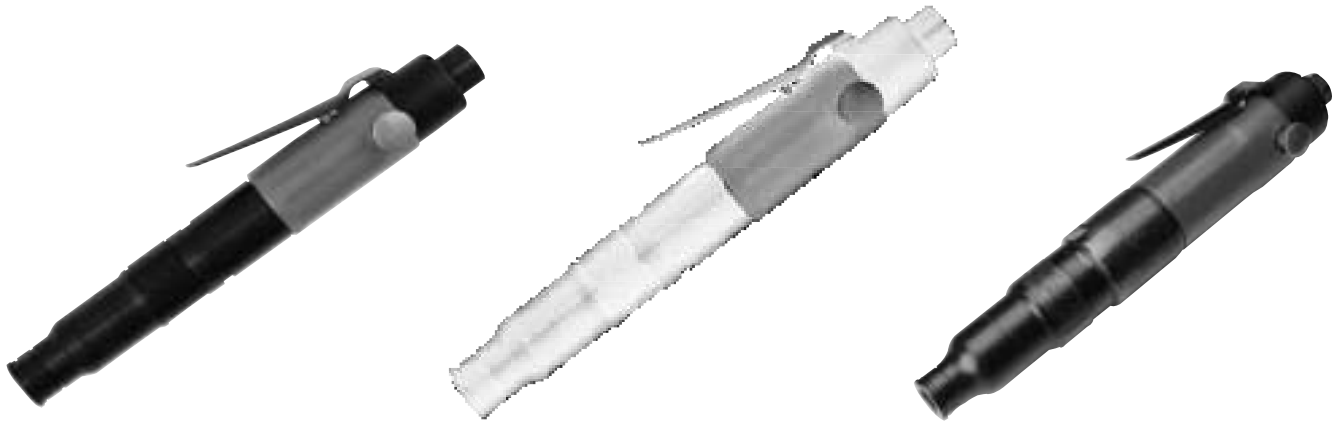

SA023B-9-Q

SL023B-15-Q

SL053B-17-Q

## Reversible In-Line Screwdrivers

Model No.	Free Speed rpm	Torque Range-Soft Draw						Tool Length in. mm		Spindle Offset in. mm		Tool Weight lbs kg		@ Free Speed Air Consp. Sound Level cfm L/s dB(A)			
		Spring in.-lbs Nm		Spring Nm		Spring in.-lbs Nm											
<b>Series 20</b>		<b>Blue</b>		<b>Yellow</b>		<b>-</b>											
<b>Push-to-Start</b>																	
SA023B-26-Q	2,600	-	-	4-12	.5-1.4	-	-	8.2	208	.60	15	1.2	.5	15	7	76	
• SA023B-15-Q	1,500	-	-	4-20	.5-2.3	-	-	8.5	217	.60	15	1.3	.6	15	7	76	
• SA023B-9-Q	900	20-30	2.3-3.4	4-20	.5-2.3	-	-	8.5	217	.60	15	1.3	.6	15	7	76	
<b>Lever Throttle</b>																	
SL023B-26-Q	2,600	-	-	4-12	.5-1.4	-	-	8.2	208	.60	15	1.2	.5	15	7	76	
• SL023B-15-Q	1,500	-	-	4-20	.5-2.3	-	-	8.5	217	.60	15	1.3	.6	15	7	76	
• SL023B-9-Q	900	20-30	2.3-3.4	4-20	.5-2.3	-	-	8.5	217	.60	15	1.3	.6	15	7	76	
<b>Series 50</b>		<b>Gray</b>		<b>Blue</b>		<b>Yellow</b>											
<b>Push-to-Start</b>																	
SA053B-25-Q	2,500	-	-	-	-	10-40	1.1-4.5	10.4	264	.80	21	2.6	1.2	25	12	78	
SA053B-17-Q	1,700	-	-	15-60	1.7-6.8	10-40	1.1-4.5	10.9	277	.80	21	2.8	1.3	25	12	78	
SA053B-10-Q	1,000	-	-	15-80	1.7-9.0	10-40	1.1-4.5	10.9	277	.80	21	2.8	1.3	25	12	78	
SA053B-8-Q	800	45-100	5.1-11.3	15-80	1.7-9.0	10-40	1.1-4.5	10.9	277	.80	21	2.8	1.3	25	12	78	
<b>Lever Throttle</b>																	
SL053B-25-Q	2,500	-	-	-	-	10-40	1.1-4.5	10.4	264	.80	21	2.9	1.4	25	12	78	
• SL053B-17-Q	1,700	-	-	15-60	1.7-6.8	10-40	1.1-4.5	10.9	277	.80	21	3.1	1.5	25	12	78	
• SL053B-10-Q	1,000	-	-	15-80	1.7-9.0	10-40	1.1-4.5	10.9	277	.80	21	3.1	1.5	25	12	78	
• SL053B-8-Q	800	45-100	5.1-11.3	15-80	1.7-9.0	10-40	1.1-4.5	10.9	277	.80	21	3.1	1.5	25	12	78	

• Most popular model.

Air Inlet – 1/4" NPTF

Recommended Air Pressure – 90 PSI (6.2 bar)

Recommended Hose Size – 5/16" (8mm)

Note: The torque values shown for a given model indicate the clutch spring(s) included with the tool. The torque value in bold type indicates the standard spring equipped in the clutch.



# Screwdrivers and Nutsetters

**Torque Output: 2 to 135 in.-lbs (.2 to 15.3 Nm)**

## Ordering Information

### Right Angle Nutsetters –

Specify the Base Model Number of the desired tool and add either a “-1” for a 1/4” Square Drive or “-2” for a 3/8” Square Drive. “-1” Not available on Series 50 R/A Nutsetters

### Right Angle Screwdrivers –

Specify the Base Model Number of the desired tool and add the appropriate Dash No. / Letter to indicate one of the following Drive Options.

- **1/4” Square Drive Assembly.**  
Add “-1” to the end of the base model number. “-1” Not available on Series 50 R/A Screwdrivers
- **1/4” Female Hex Bit Holder.**  
Add “-H” to the end of the base model number.
- **Standard Length Finder.**  
Add “-F” to the end of the base model number and specify one of the Finder Kits listed in the chart at right.  
Note: Finder option is not available on SR023B-()L-().

**Example: SR023B-25L-H**

### Right Angle Heads available:

- “L” – Light Duty (aircraft head)
- “R” – Regular Duty
- “H” – Heavy Duty

Finder Kit	Screw Size		Bit to Use Order Separately
	Flat head	Round head	
46343-1	1	2	F164
46343-2	2	3	F1645
46343-3	3	4	XF165
46343-4	4	5	XF166
46343-5	5	6	XF167
46343-6	6	8	XF168
46343-8	8	10	XF169
46343-10	10	12	XF1610

Note: Tools ordered with the **Finder Option** will not accommodate the “-Q”, options. Consult factory.



SR023B-17R-I



SR053B-16R-H

## Reversible Right Angle Screwdrivers

Model No.	Free Speed rpm	Torque Range-Soft Draw						Tool Length		Spindle Offset		Tool Weight		@ Free Speed		
		Spring in.-lbs	Spring Nm	Spring in.-lbs	Spring Nm	Spring in.-lbs	Spring Nm	in.	mm	in.	mm	lbs	kg	Air Consp. cfm	Sound Level dB(A)	
<b>Series 20</b>		Gray		Blue		Yellow										
SR023B-48L-()	4,800	-	-	-	-	2-5	.2-.6	12.9	328	0.33	8.3	2.1	0.95	15	7	76
SR023B-25L-()	2,500	-	-	-	-	4-10	.4-1.1	12.9	328	0.33	8.3	2.1	0.95	15	7	76
SR023B-14L-()	1,000	-	-	-	-	4-17	.4-1.9	13.3	338	0.33	8.3	2.2	1.00	15	7	76
SR023B-9L-()	900	-	-	-	-	6-23	.7-2.6	13.3	338	0.33	8.3	2.2	1.00	15	7	76
SR023B-17R-()	1,750	-	-	-	-	7-16	.8-1.8	11.9	302	0.58	14.8	2.2	1.00	15	7	76
SR023B-10R-()	1,000	-	-	-	-	10-26	1.1-2.9	11.9	302	0.58	14.8	2.3	1.00	15	7	76
SR023B-5R-()	500	-	-	25-40	2.8-4.5	10-26	1.1-2.9	12.4	315	0.58	14.8	2.3	1.00	15	7	76
<b>Series 50</b>																
SR053B-16R-()	1,650	-	-	-	-	25-58	2.8-6.5	13.5	343	0.58	14.7	3.6	1.60	25	12	80
SR053B-9R-()	950	-	-	25-90	2.8-10.2	25-58	2.8-6.5	14.0	356	0.58	14.7	3.8	1.70	25	12	80
SR053B-11H-()	1,150	-	-	20-70	2.2-7.9	-	-	14.2	360	0.65	16.5	4.0	1.80	25	12	80
SR053B-8H-()	800	-	-	25-100	2.8-11.3	-	-	14.2	360	0.65	16.5	4.0	1.80	25	12	80
SR053B-6H-()	500	40-135	4.5-15.3	25-100	2.8-11.3	-	-	14.2	360	0.65	16.5	4.0	1.80	25	12	80

Air Inlet – 1/4” NPTF

Recommended Air Pressure – 90 PSI (6.2 bar)

Recommended Hose Size – 5/16” (8mm)

Note: The torque values shown for a given model indicate the clutch spring(s) included with the tool. The torque value in bold type indicates the standard spring equipped in the clutch.



**Toll-Free 1-866-763-6226 Phone: 905-672-5557**  
**Fax: 905-672-5559 Email: sales@dobcoeqp.com**

# Screwdrivers and Nutsetters

**Torque Output: 2 to 135 in.-lbs (.2 to 15.3 Nm)**



NR023B-10R-1



NR053B-9R-2

## Reversible Right Angle Nutsetters

Model No.	Free Speed rpm	Torque Range-Soft Draw						Tool Length		Spindle Offset		Tool Weight		@ Free Speed		
		Spring		Spring		Spring		in.	mm	in.	mm	lbs	kg	Air Consp.	Sound Level	
		in.-lbs	Nm	in.-lbs	Nm	in.-lbs	Nm							cfm	L/s	dB(A)
<b>Series 20</b>		Gray		Blue		Yellow										
NR023B-17R-(-)	1,750	-	-	-	-	7-16	.8-1.8	11.9	302	0.58	14.8	2.2	1.00	15	7	76
NR023B-10R-(-)	1,000	-	-	-	-	10-26	1.1-2.9	11.9	302	0.38	14.8	2.3	1.00	15	7	76
NR023B-5R-(-)	500	-	-	25-40	2.8-4.5	10-26	1.1-2.9	12.4	315	0.58	14.8	2.3	1.00	15	7	76
<b>Series 50</b>																
NR053B-16R-(-)	1,650	-	-	-	-	25-58	2.8-6.5	13.5	343	0.58	14.7	3.6	1.60	25	12	80
NR053B-9R-(-)	950	-	-	25-90	2.8-10.2	25-58	2.8-6.5	14.0	356	0.58	14.7	3.8	1.70	25	12	80
NR053B-11H-(-)	1,150	-	-	20-70	2.2-7.9	-	-	14.2	360	0.65	16.5	4.0	1.80	25	12	80
NR053B-8H-(-)	800	-	-	25-100	2.8-11.3	-	-	14.2	360	0.65	16.5	4.0	1.80	25	12	80
NR053B-6H-(-)	500	40-135	4.5-15.3	25-100	2.8-11.3	-	-	14.2	360	0.65	16.5	4.0	1.80	25	12	80

Air Inlet – 1/4" NPTF

Recommended Air Pressure – 90 PSI (6.2 bar)

Recommended Hose Size – 5/16" (8mm)

Note: The torque values shown for a given model indicate the clutch spring(s) included with the tool. The torque value in bold type indicates the standard spring equipped in the clutch.

# Screwdrivers and Nutsetters

Torque Output: 12 to 120 in.-lbs (1.4 to 13.6 Nm)



SG022B-15-Q



SG052B-17-Q

## Reversible Pistol Grip Screwdrivers

Model No. with Angle Jaws	Model No. with 90° Jaws	Free Speed rpm	Stall <sup>1</sup> Torque		Tool Length		Spindle Offset		Tool Weight		© Free Speed		
			in.-lbs	Nm	in.	mm	in.	mm	lbs	kg	Air Consp. cfm	L/s	Sound Level dB(A)
<b>Series 20</b>													
SG022B-26-Q	SG029B-26-Q	2,600	12	1.4	5.1	131	.66	17	1.5	.7	15	7	76
• SG022B-15-Q	SG029B-15-Q	1,500	25	2.8	5.5	140	.66	17	1.6	.7	15	7	76
• SG022B-9-Q	SG029B-9-Q	900	38	4.3	5.5	140	.66	17	1.6	.7	15	7	76
<b>Series 50</b>													
• SG052B-25-Q	SG059B-25-Q	2,500	45	4.0	7.2	182	.8	21	2.4	1.1	25	12	78
• SG052B-17-Q	SG059B-17-Q	1,700	65	7.3	7.6	194	.8	21	2.6	1.2	25	12	78
• SG052B-10-Q	SG059B-10-Q	1,000	90	10.2	7.6	194	.8	21	2.6	1.2	25	12	78
SG052B-8-Q	SG059B-8-Q	800	120	13.6	7.6	194	.8	21	2.6	1.2	25	12	78

• Most popular model.

Air Inlet – 1/4" NPTF

Recommended Air Pressure – 90 PSI (6.2 bar)

Recommended Hose Size – 5/16" (8mm)

(1) Operator technique controls final torque input on models with angle clutch jaws.



# Screwdrivers and Nutsetters

**Torque Output: 12 to 120 in.-lbs (1.4 to 13.6 Nm)**



SL022B-9-Q



SL052B-10-Q

### Reversible In-Line Screwdrivers

Model No. with Angle Jaws	Model No. with 90° Jaws	Free Speed rpm	Stall <sup>1</sup> Torque		Tool Length		Spindle Offset		Tool Weight		© Free Speed		
			in.-lbs	Nm	in.	mm	in.	mm	lbs	kg	Air Cons. cfm	L/s	Sound Level dB(A)
<b>Series 20</b>													
SL022B-26-Q	SL029B-26-Q	2,600	12	1.4	6.7	169	.6	15	1.0	.5	15	7	76
SL022B-15-Q	SL029B-15-Q	1,500	25	2.8	7.0	178	.6	15	1.1	.5	15	7	76
SL022B-9-Q	SL029B-9-Q	900	38	4.3	7.0	178	.6	15	1.1	.5	15	7	76
<b>Series 50</b>													
SL052B-25-Q	SL059B-25-Q	2,500	45	4.0	8.6	219	.8	21	2.4	1.1	25	12	78
SL052B-17-Q	SL059B-17-Q	1,700	65	7.3	9.1	232	.8	21	2.6	1.2	25	12	78
SL052B-10-Q	SL059B-10-Q	1,000	90	10.2	9.1	232	.8	21	2.6	1.2	25	12	78
SL052B-8-Q	SL059B-8-Q	800	120	13.6	9.1	232	.8	21	2.6	1.2	25	12	78

Air Inlet – 1/4" NPTF  
 Recommended Air Pressure – 90 PSI (6.2 bar)  
 Recommended Hose Size – 5/16" (8mm)  
 (1) Operator technique controls final torque input on models with angle clutch jaws.

### More Power... Lower Maintenance Cost

- Positive clutch design transfers more power to the screw head.
- Front and rear clutch jaws are interchangeable, low-cost parts.



7672-A18

### Reversible Woodworking Screwdriver

Model No.	Free Speed rpm	Stall Torque in.-ft	Nm	Tool Length in.	mm	Spindle Offset in.	mm	Tool Weight lbs	kg	Bit Holder Hex in.	Air Inlet NPT in.	Air Cons. cfm	© Free Speed
7672-A18	1,800	6.2	8.4	6.6	169	0.86	22	2.6	1.2	1/4	1/4	27	

• Most popular model.  
 Air Inlet – 1/4" NPTF  
 Recommended Air Pressure – 90 PSI (6.2 bar)  
 Recommended Hose Size – 5/16" (8mm)

# Direct Drive Tools

## Screwdrivers and Nutsetters

### Torque Output: 12 to 120 in.-lbs (1.4 to 13.6 Nm)

Tools are equipped with a Quick-Change Assembly (-Q Drive Option) as standard. To order a tool equipped with a (FINDER) option, specify the following option at no extra cost:

- Standard Length Finder.**

Change the "-Q" in the model number to "-F" and specify one of the FINDER KITS listed in the chart at right.

**Note:** Apex Magnetic Bit Holder (40259), and Magna Magnetic Bit Holder (36585) may be ordered separately.

**Example:** SG021B-15-F with 46343-4. Order bit separately.



Quick-Change Assembly (Q)

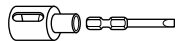

Standard Length Finder (F)

Finder Kit	Screw Size		Bit to Use Order Separately
	Flat head	Round head	
46343-1	1	2	F164
46343-2	2	3	F1645
46343-3	3	4	XF165
46343-4	4	5	XF166
46343-5	5	6	XF167
46343-6	6	8	XF168
46343-8	8	10	XF169
46343-10	10	12	XF1610

**Note:** Tools ordered with the **Finder Option** will not accommodate the "-Q", options. Consult factory.

### Reversible Pistol Grip Screwdrivers

Model No.	Free Speed rpm	Stall Torque		Tool Length		Spindle Offset		Tool Weight		@ Free Speed		
		in.-lbs	Nm	in.	mm	in.	mm	lbs	kg	Air Consp. cfm	L/s	Sound Level dB(A)
<b>Series 20</b>												
• SG021B-26-Q	2,600	12	1.4	4.6	118	.66	17	1.3	.6	15	7	76
• SG021B-15-Q	1,500	25	2.8	5.0	128	.66	17	1.4	.6	15	7	76
• SG021B-9-Q	900	38	4.3	5.0	128	.66	17	1.4	.6	15	7	76
<b>Series 50</b>												
• SG051B-25-Q	2,500	45	4.0	6.9	175	.8	21	2.2	1.0	25	12	78
• SG051B-17-Q	1,700	65	7.3	7.4	187	.8	21	2.4	1.1	25	12	78
• SG051B-10-Q	1,000	90	10.2	7.4	187	.8	21	2.4	1.1	25	12	78
• SG051B-8-Q	800	120	13.6	7.4	187	.8	21	2.4	1.1	25	12	78

• Most popular model.

Air Inlet – 1/4" NPTF

Recommended Air Pressure – 90 PSI (6.2 bar)

Recommended Hose Size – 5/16" (8mm)



SG021B-26-Q



SG051B-17-Q



SL021B-15-Q



SL051B-17-Q

### Reversible In-Line Screwdrivers

Model No.	Free Speed rpm	Stall Torque		Tool Length		Spindle Offset		Tool Weight		@ Free Speed		
		in.-lbs	Nm	in.	mm	in.	mm	lbs	kg	Air Consp. cfm	L/s	Sound Level dB(A)
<b>Series 20</b>												
• SL021B-26-Q	2,600	12	1.4	6.2	157	.6	15	.9	.4	15	7	76
• SL021B-15-Q	1,500	25	2.8	6.5	167	.6	15	1.0	.5	15	7	76
• SL021B-9-Q	900	38	4.3	6.5	167	.6	15	1.0	.5	15	7	76
<b>Series 50</b>												
• SL051B-25-Q	2,500	45	4.0	8.1	206	.8	21	2.2	1.0	25	12	78
• SL051B-17-Q	1,700	65	7.3	8.9	225	.8	21	2.4	1.1	25	12	78
• SL051B-10-Q	1,000	90	10.2	8.9	225	.8	21	2.4	1.1	25	12	78
• SL051B-8-Q	800	120	13.6	8.9	225	.8	21	2.4	1.1	25	12	78

• Most popular model.

Air Inlet – 1/4" NPTF

Recommended Air Pressure – 90 PSI (6.2 bar)

Recommended Hose Size – 5/16" (8mm)

# Screwdrivers and Nutsetters

**Torque Output: 5.5 to 150 in.-lbs (.6 to 17 Nm)**

## Ordering Information

### Right Angle Nutsetters –

Specify the Base Model Number of the desired tool and add either a “-1” for a 1/4” Square Drive or “-2” for a 3/8” Square Drive.

“-1” not available on SR021B-5R and Series 50 R/A Nutsetters.

### Right Angle Screwdrivers –

Specify the Base Model Number of the desired tool and add the appropriate Dash No. / Letter to indicate one of the following Drive Options.

“-1” Not available on SR021B-5R and Series 50 R/A Screwdrivers

- **1/4” Square Drive Assembly.**

Add “-1” to the end of the base model number.

- **1/4” Female Hex Bit Holder.**

Add “-H” to the end of the base model number.

- **Standard Length Finder.**

Add “-F” to the end of the base model number and specify one of the Finder Kits listed in the chart on page 20.

Note: Finder option is not available on SR021B-( )L-( ).

**Example: SR021B-25L-H**

### Right Angle Heads available:

“L” – Light Duty (aircraft head)<sup>1</sup>

“R” – Regular Duty

“H” – Heavy Duty

(1) Square drive not available



SR021B-25L-H



SR051B-24R-H

## Reversible Right-Angle Screwdrivers

Model No.	Free Speed rpm	Stall Torque		Tool Length		Spindle Offset		Tool Weight		@ Free Speed		
		in.-lbs	Nm	in.	mm	in.	mm	lbs	kg	Air Cons. cfm	L/s	Sound Level dB(A)
<b>Series 20</b>												
SR021B-48L-( )	4,800	5.5	.6	10.3	262	0.33	8.3	1.50	0.70	15	7	76
SR021B-25L-( )	2,500	11	1.2	10.3	262	0.33	8.3	1.50	0.70	15	7	76
SR021B-14L-( )	1,400	18	2.0	10.7	272	0.33	8.3	1.60	0.75	15	7	76
SR021B-33R-( )	3,300	8	.9	9.5	241	0.58	14.8	1.65	0.75	15	7	76
SR021B-17R-( )	1,750	17	1.9	9.5	241	0.58	14.8	1.65	0.75	15	7	76
SR021B-10R-( )	1,000	27	3.0	9.9	252	0.58	14.8	1.75	0.80	15	7	76
SR021B-5R-( )	500	53	6.0	9.9	252	0.58	14.8	1.75	0.80	15	7	76
<b>Series 50</b>												
SR051B-24R-( )	2,400	41	4.6	10.7	272	0.58	14.7	2.60	1.20	25	12	80
SR051B-16R-( )	1,600	62	7.0	10.7	272	0.58	14.7	2.60	1.20	25	12	80
SR051B-11H-( )	1,150	80	9.0	11.3	287	0.65	16.5	3.00	1.40	25	12	80
SR051B-8H-( )	800	120	13.5	11.3	287	0.65	16.5	3.00	1.40	25	12	80
SR051B-6H-( )	600	150	17.0	11.3	287	0.65	16.5	3.00	1.40	25	12	80

Air Inlet – 1/4” NPTF

Recommended Air Pressure – 90 PSI (6.2 bar)

Recommended Hose Size – 5/16” (8mm)

# Screwdrivers and Nutsetters

**Torque Output: 5.5 to 150 in.-lbs (.6 to 17 Nm)**

## Ordering Information

### Right Angle Nutsetters –

Specify the Base Model Number of the desired tool and add either a “-1” for a 1/4” Square Drive or “-2” for a 3/8” Square Drive.

“-1” Not available on NR021B-5R and Series 50 R/A Nutsetters

### Right Angle Screwdrivers –

Specify the Base Model Number of the desired tool and add the appropriate Dash No. / Letter to indicate one of the following Drive Options.

- **1/4” Square Drive Assembly.**  
Add “-1” to the end of the base model number.  
“-1” Not available on NR021B-5R and Series 50 R/A Screwdrivers
- **1/4” Female Hex Bit Holder.**  
Add “-H” to the end of the base model number.
- **Standard Length Finder.**  
Add “-F” to the end of the base model number and specify one of the Finder Kits listed in the chart on page 20.

**Example: NR021B-10R-1**

### Right Angle Heads available:

“R” – Regular Duty

“H” – Heavy Duty



NR021B-33R-1

NR051B-16R-2

## Reversible Right-Angle Nutsetters

Model No.	Free Speed rpm	Stall Torque		Tool Length		Spindle Offset		Tool Weight		@ Free Speed		
		in.-lbs	Nm	in.	mm	in.	mm	lbs	kg	Air Consp. cfm	L/s	Sound Level dB(A)
<b>Series 20</b>												
NR021B-33R-()	3,300	8	.9	9.5	241	0.58	14.8	1.78	0.81	15	7	76
NR021B-17R-()	1,750	17	1.9	9.5	241	0.58	14.8	1.78	0.81	15	7	76
NR021B-10R-()	1,000	27	3.0	9.9	252	0.38	14.8	1.90	0.86	15	7	76
NR021B-5R-()	500	53	6.0	9.9	252	0.38	14.8	1.90	0.86	15	7	76
<b>Series 50</b>												
NR051B-24R-()	2,400	41	4.6	10.7	272	0.58	14.7	2.65	1.20	25	12	80
NR051B-16R-()	1,600	62	7.0	10.7	272	0.58	14.7	2.65	1.20	25	12	80
NR051B-11H-()	1,150	80	9.0	14.2	360	0.65	16.5	4.00	1.80	25	12	80
NR051B-8H-()	800	120	13.5	14.2	360	0.65	16.5	4.00	1.80	25	12	80
NR051B-6H-()	600	150	17.0	14.2	360	0.65	16.5	4.00	1.80	25	12	80

Air Inlet – 1/4” NPTF

Recommended Air Pressure – 90 PSI (6.2 bar)

Recommended Hose Size – 5/16” (8mm)

# Screwdrivers and Nutsetters

**Torque Output: 17 to 62 in.-lbs (1.9 to 7.0 Nm)**

## Series 20 / 50 Reversible Right-Angle Screwdrivers

1000 to 1750 RPM

The SRB models are the latest additions to the extensive line of ARO assembly tools. They combine the convenience of pushbutton reverse control with the superior performance standards established by the ARO Series 20 and 50 tools. All six models are right angle, direct drive configurations, with torque output determined by the stall torque of the motor at a given air pressure. The SRB models are perfect for light assembly applications involving limited access spaces in furniture and sheet metal production. Simple functional design and top quality production help insure long service life.

Contact your local ARO distributor or representative for complete details.

- Pushbutton reverse for one-handed operation.
- Direct drive, 1000 – 1750 RPM range.
- 17 – 62 in.lbs. torque range.
- (-H models utilize insert bit spindles)
- (-P models utilize power bit spindles)

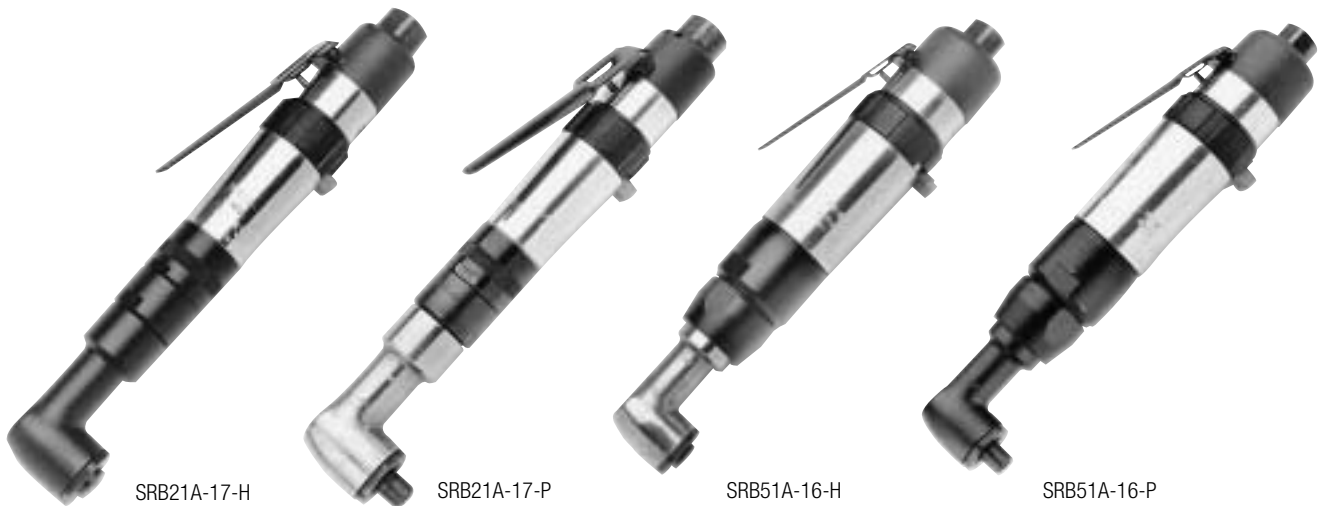

### SRB Reversible Right-Angle Screwdrivers

Model No.	Free Speed rpm	Stall Torque		Tool Weight		Spindle Offset		Tool Length		Angle Height		@ Free Speed Air Consp.		Sound Level dB(A)
		in.-lbs	Nm	lbs	kg	in.	mm	in.	mm	in.	mm	cfm	L/s	
<b>Series 20</b>														
SRB21A-10-H	1,000	30	3.4	1.8	0.8	.54	13.7	9.77	248	1.46	37	15	7	74
SRB21A-10-P	1,000	30	3.4	1.8	0.8	.54	13.7	9.77	248	1.80	46	15	7	74
SRB21A-17-H	1,750	17	1.9	1.7	0.8	.54	13.7	9.47	240	1.46	37	15	7	74
SRB21A-17-P	1,750	17	1.9	1.7	0.8	.54	13.7	9.47	240	1.80	46	15	7	74
<b>Series 50</b>														
SRB51A-16-H	1,600	62	7.0	2.8	1.3	.54	13.7	10.77	274	1.46	37	25	12	76
SRB51A-16-P	1,600	62	7.0	2.8	1.3	.54	13.7	10.77	274	1.80	46	25	12	76

Air Inlet – 1/4" NPTF

Recommended Air Pressure – 90 PSI (6.2 bar)

Recommended Hose Size – 9/16" (8mm)



# Screwdrivers and Nutsetters

**Torque Output: 2 to 24 ft-lbs (3.0 to 33 Nm)**

## Series 50 Right-Angle Nutsetter

400 to 2,400 RPM

- Complete selection of speeds, torque outputs, and drive spindles in both shutoff and stall models ensures the most efficient, cost-effective tool for the fastening application.
- Torque control shutoff models deliver precise, consistent torque output and effectively minimize reaction torque transmitted to the operator.
- Small angle head height enables easy access to tight areas, reducing assembly time and minimizing costly dedicated tooling.
- Protective vinyl boot on the angle housing helps prevent marring the product's finish during assembly.
- Lightweight construction and compact size make for easy handling and control over extended periods of time.
- Superior angle bevel gears give excellent service life.
- Full-circle positioning of the angle head relative to the throttle allows a tool to be set up for a specific fastener location.

Tool Free Speed	Sq. Drives (Dash No.)	
	3/8" (-2)	1/2" (-3)
400	•	•
600	•	•
800	•	•
1,000	•	•
1,600	•	-
2,400	•	-

• Indicates the speeds on which a particular option is available.



NA051A-10-2



NA054A-16-2

## Series 50 Right-Angle Nutsetters

Model No.	Free Speed rpm	Stall Torque				Tool Length		Angle Height		Spindle Offset		Tool Weight		@ Free Speed		
		@ 50 PSI ft-lbs	@ 90 PSI Nm	@ 50 PSI ft-lbs	@ 90 PSI Nm	in.	mm	in.	mm	in.	mm	lbs	kg	Air Consp. cfm	Sound Level L/s dB(A)	
<b>Reversible Stall</b>																
NA051A-24-(-)	2,400	2.4	3.2	3.8	5.2	10.2	259	1.4	36	.56	14	2.8	1.3	25	12	80
NA051A-16-(-)	1,600	3.5	4.7	7.0	11.0	10.2	259	1.4	36	.56	14	2.8	1.3	25	12	80
NA051A-10-(-)	1,000	6.0	9.0	11.0	15.0	10.7	272	1.4	36	.64	16	3.1	1.4	25	12	80
NA051A-8-(-)	800	8.0	11.0	13.0	18.0	10.8	274	1.7	43	.64	16	3.3	1.5	25	12	80
NA051A-6-(-)	600	10.0	14.0	16.0	22.0	10.8	274	1.7	43	.64	16	3.3	1.5	25	12	80
NA051A-4-(-)	400	14.0	19.0	24.0	33.0	10.8	274	1.7	43	.64	16	3.3	1.5	25	12	80
<b>Reversible Auto Shut-Off</b>																
NA054A-24-(-)	2,400	2.0	3.0	3.2	4.0	12.3	312	1.4	36	.56	14	3.5	1.6	25	12	80
NA054A-16-(-)	1,600	3.0	4.0	5.5	7.5	12.3	312	1.4	36	.56	14	3.5	1.6	25	12	80
NA054A-10-(-)	1,000	5.0	7.0	9.0	12.0	12.8	325	1.4	36	.64	16	3.7	1.7	25	12	80
NA054A-8-(-)	800	7.0	9.5	11.0	15.0	12.9	328	1.7	43	.64	16	3.9	1.8	25	12	80
NA054A-6-(-)	600	8.0	11.0	13.0	18.0	12.9	328	1.7	43	.64	16	3.9	1.8	25	12	80
NA054A-4-(-)	400	11.0	15.0	21.0	28.0	12.9	328	1.7	43	.64	16	3.9	1.8	25	12	80

Air Inlet – 1/4" NPTF  
 Recommended Air Pressure – 90 PSI (6.2 bar)  
 Recommended Hose Size – 5/16" (8mm)  
 Refer to chart at top right for square drive options.

# Production Nutsetters Screwdrivers and Nutsetters

**Torque Output: 18 to 90 in.-lbs (2.0 to 10.2 Nm)**

## Flat-Angle Nutsetter

**1,600 RPM / .2 HP (.1 kW)**

- Designed for limited access, light-assembly applications, including major appliances, sheet metal, and steel furniture manufacturing.
- Angle rotates 360° for ease of operation.

**850 & 1450 RPM / .33 HP (.2 kW)**

- Designed for limited access, light-assembly applications, including major appliances, sheet metal, and steel furniture manufacturing.
- Angle rotates 360° for ease of operation.

### Standard Equipment

- Suspension Bail
- Hex (female) Socket Spindle



## Flat-Angle Nutsetters

Model No.	Free Speed rpm	Clutch Type	Hex Drive Size (Female) in.	Stall Torque		Tool Length		Angle Height		Spindle Offset		Tool Weight		@ Free Speed		Std. Spindle Part No.	
				in.-lbs	Nm	in.	mm	in.	mm	in.	mm	lbs	kg	Air Consp. cfm	Sound Level L/s dB(A)		
7509-E	1600	Direct Drive	3/8	18	2.0	10.3	262	.7	18	.5	13	2.6	1.2	16	7	85	33532-5
7456-D	1450	Direct Drive	3/8	54	6.1	11.0	279	.7	18	.5	13	2.9	1.3	23	11	87	33532-5
7453-D	850	Direct Drive	3/8	90	10.2	12.3	312	.7	18	.5	13	3.4	1.5	23	11	87	33532-5

Air Inlet – 1/4" NPTF  
Recommended Air Pressure – 90 PSI (6.2 bar)  
Recommended Hose Size – 5/16" (8mm)

### No Cost Options (Order "With" Option)

For Models	Part No.	Description	See Page	Substitute for standard
All	–	Hex (Female) Socket Spindle	See Below	Socket Spindle
All	33542	1/4" SQ. Drive Adapter	–	–

### Extra Cost Accessories

For Models	Part No.	Description
7456	44360-(-)	Piped Exhaust Assembly
7453	44360-(-)	Piped Exhaust Assembly

### Hex (Female) Socket Spindles

Spindle Part No.	Hex Size in.	Spindle Part No.	Hex Size in.	Spindle Part No.	Hex Size in.
33532-1	1/4	33532-5 <sup>1</sup>	3/8	33532-9	1/2
33532-2	9/32	33532-6	13/32	33532-10	17/32
33532-3	5/16	33532-7	7/16	33532-11	9/16
33532-4	11/32	33532-8	15/32	-	-

(1) Standard

# SE Series Screwdrivers

The SE Series Screwdriver is the latest expression of the ARO design philosophy - creating products that truly reflect the needs of their users.

This versatile DC electric screwdriver combines industry-leading torque accuracy and repeatability with unmatched flexibility and serviceability for light duty, precision assembly applications. At the same time, it sets new standards for ergonomics and operator comfort.



The SE Series Screwdriver's unique appearance immediately signals its difference from anything else in its class. The egg-shaped oval grip fits the hand. The soft touch grip surface feels good and maintains a comfortable temperature. All controls are positioned for easy use by right or left-handed operators.

It delivers exceptional performance at lower sound levels while consuming less power than competitive models (see tables below). It also provides the bottom line benefit of low cost of ownership through flexibility, durability, and reliability.

Throughout the development of the SE Series Screwdriver, assembly experts conducted research in varied industries around the world. We took dozens of attributes into account. The tool had to be accurate and easy to maintain. It had to adapt to a host of applications — from installing a hinge on a microwave door to fastening microchips inside a computer.

We went to the assembly lines and talked to workers, engineers, and managers. We listened to their complaints and suggestions. We considered their hands-on experience and their sound ideas.

The SE Series Screwdriver is the answer to their input. In all of its external and internal detail, it represents substance over mere cosmetics. It is the next step for precision assembly applications in performance, ergonomics, and versatility.

### Torque Accuracy

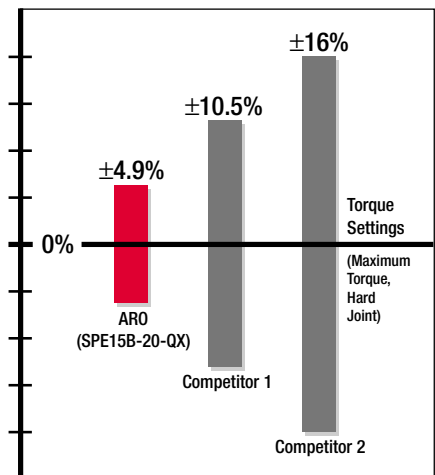

Accuracy may vary depending on model and application.

# DC Electric Screwdrivers

## SE Series Screwdrivers

The SE Series Screwdriver is the Best-In-Class hand-held corded electric screwdriver in the .3 to 40 in.-lbs. category. It incorporates more than a dozen innovative features, and is available in two basic types: high torque and low torque.

### High Torque

The transformerless 115V version is for tasks which require higher torque. This version can be outfitted in three configurations: straight, pistol, and angle - with activation by push-to-start, lever, or trigger. These options, plus accessories for suspending the tool in various positions, provide a solution to virtually every light-assembly application.

### Low Torque with Controller

The 24V version is intended for tasks in which low torque output and speed control are required. The controller serves to activate special features, including soft-start, which allows for the proper positioning of the smallest screws; and run-down speed, which provides application adjustment without changing tools.

### Noise Level

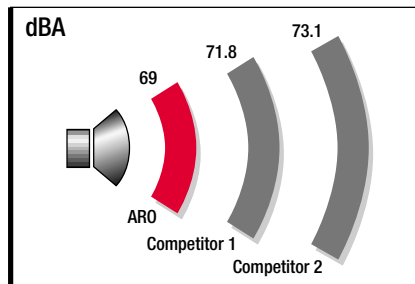

### Power Consumption

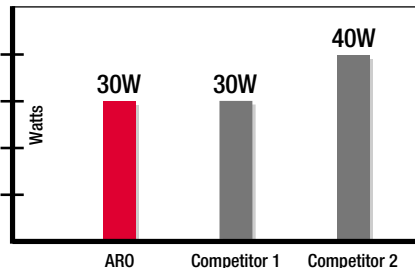

## Three Different Configurations

### Straight

The basic platform of the SE Series Screwdriver, the straight tool, varies in size according to high or low torque versions. It can be configured in dozens of ways through attachments, accessories and adjustments.

### Angle Head (High Torque)

Used with lever models, this configuration allows the SE Series Screwdriver to be exceptionally maneuverable in tight spaces. It is available in three versions: 1/4" female hex drive; 1/4" male hex drive; and with a 1/4" male hex aerospace industry-type head.

### Pistol Grip (High Torque)

The pistol grip can be attached to the lever or push-to-start models, readying the tool instantly for tasks in which a gripping action is required. The pistol attachment has a soft touch surface with a two-finger trigger to evenly distribute grip forces.

DC Electric Screwdrivers  
**SE Series Screwdrivers**

**External Features**

The SE Series Screwdriver represents major advances in design, engineering, and construction...all intended to deliver accuracy, sound ergonomics, and versatility. All versions are based on a common platform as shown below, with supplemental components to address specific needs. A complete assembly line can be outfitted without requiring a huge inventory of spares and variations.

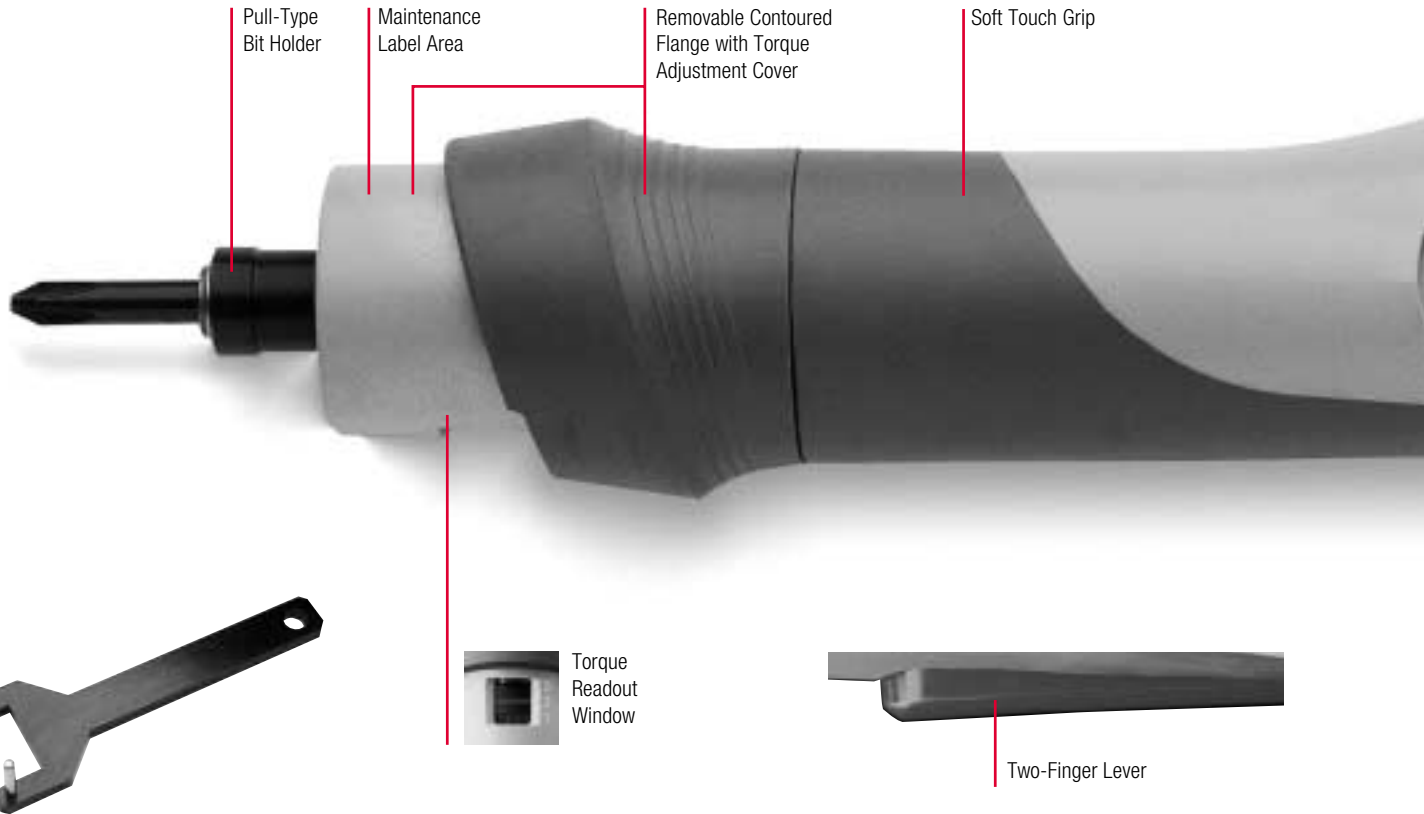

**Torque Adjusting Tool (Optional)**

Used for torque adjustments without removing the adjustment cover. Perfect for on-the-line torque adjustments by authorized personnel.

**Torque Readout Window**

This convenient feature provides instant confirmation of torque output setting.

**Removable Contoured Flange with Torque Adjustment Cover**

The contoured, slanted flange follows the shape of the user's hand and doubles as a torque adjustment cover. It solves the problem of unauthorized torque setting changes. With the SE Series Screwdriver, only a technician using a special tool can reset the torque from the exterior. Yet the cover itself is removable, a convenience when it comes to repair or for torque adjustment by hand.

**Soft Touch Grip**

The unique, egg-shaped grip allows users to hold the tool comfortably without excess force. Engineered to fit almost every hand size, the grip is made from a composite material that provides a soft texture and maintains a relatively constant temperature for comfort and control throughout a shift.

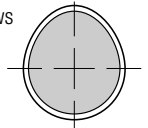

**Two-Finger Lever**

The two-finger lever distributes pressure and provides notable ergonomic benefits in continuous use applications.

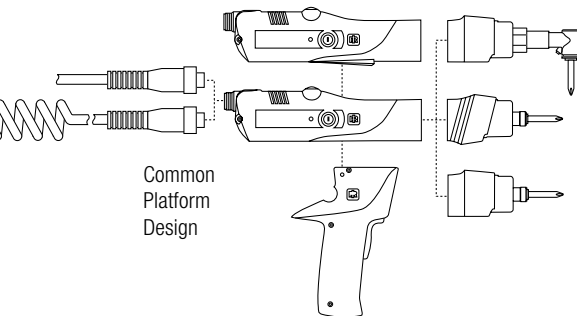
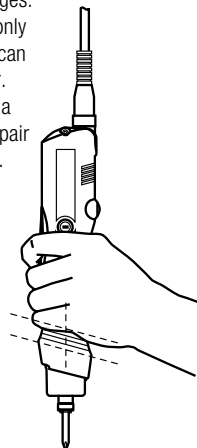

Common Platform Design



# DC Electric Screwdrivers

## SE Series Screwdrivers



### Brush Replacement Light

The brush replacement light illuminates while the tool is rotating to indicate service required at the next shift, promoting good tool maintenance.

### Easy Forward/Reverse

Only one hand is needed to change direction. The forward/reverse toggle is easily accessible, activated smoothly by either the left or right hand. Competitive models require two-handed changes in direction.

### Innovative Cord Connector

**Easy Removal:** The electric power cord, available in a straight or coiled version, is easily detached from the tool by loosening the threaded retainer.

**Dual Positioning:** The cord can be attached either at the top or the side. This means that in whatever position the tool is being used, the cord stays out of the way of the operator and the work.

### Controller For Low Torque Models

#### Variable Speed Adjustment

Adapts the tool to different applications without having to change models.

#### Variable Soft Start

Makes positioning of small screws easy.

#### Signal Output

An optional counter can be attached. This allows for monitoring of group fastening.

#### Mounting Holes

A mounting bracket can be purchased separately for fixturing the controller.

#### Soft Touch and Small Size

A perfect match for delicate operations.

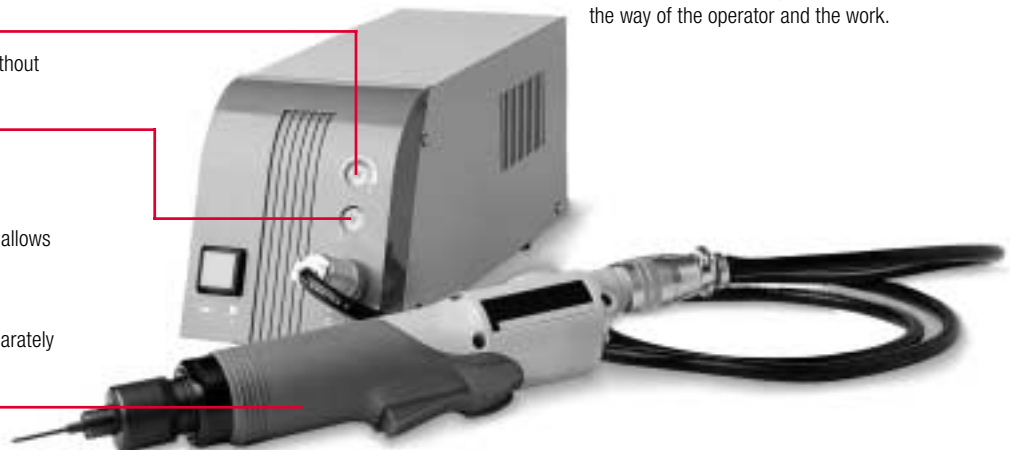

# DC Electric Screwdrivers

## SE Series Screwdrivers

### Internal Features

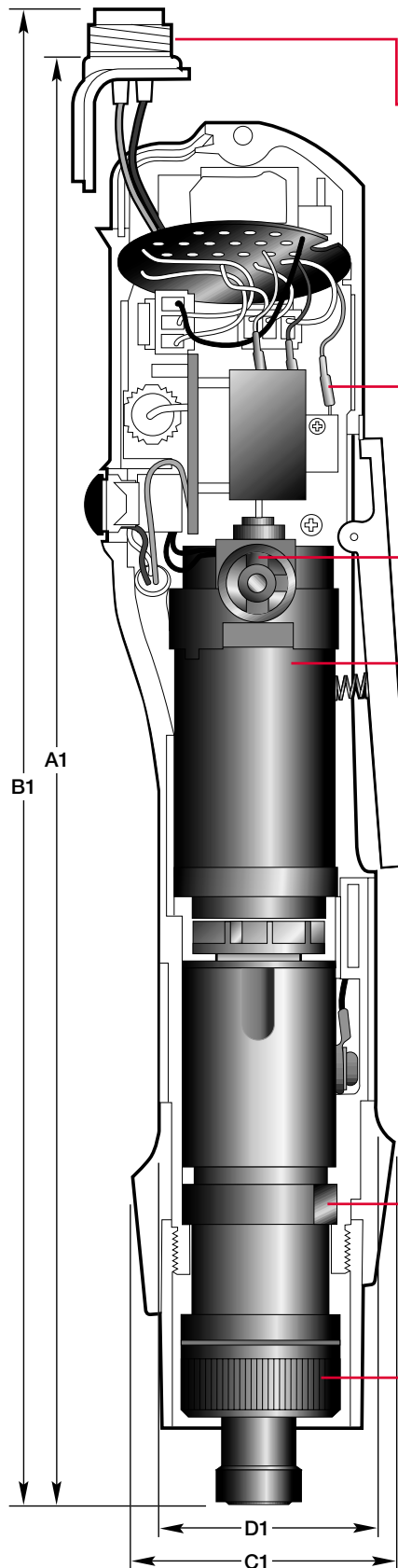

With easy, single-fastener access to the interior, the SE Series Screwdriver has been engineered for fast and simple maintenance.

#### Cord Receptacle

Cord orientation can easily be changed by rotating the receptacle to top or side position while the tool is open.

#### Quick Connectors

It is easy to make electronic repairs, as the controller is replaced by unplugging its quick connectors. On competitive models, it is necessary to cut and then resolder up to eight wires.

#### Easy Brush Replacement

Brush wear and replacement are signalled by the convenient external indicator light. Brushes can easily be replaced without opening the tool.

#### DC Motor

Provides unmatched durability and performance. Duty cycles vary depending on the application.

#### General Rating:

- 0.8 sec. on, 3.2 sec. off
- 0.5 sec. on, 3.5 sec. off (2000 and 1200 rpm models only)

#### Clutch Assembly

Automatic shut-off clutch provides accuracy and precision. One clutch design is common to all high torque models.

#### Torque Adjuster

The internal adjuster allows for a wide range of torque settings and speeds, tailoring the tool for virtually any light-assembly application.

### Model Identification

#### High Torque

- Power: 115V AC
- Cable Length: 8 ft. Straight
- Sound: 69 dBA
- Reversible: Yes



<b>S</b>	<b>P</b>	<b>E</b>	<b>15</b>	<b>B</b>	<b>-</b>	<b>20</b>	<b>-</b>	<b>Q</b>
<b>Tool</b>	<b>Type</b>	<b>Tool</b>	<b>Free Speed</b>	<b>Spindle Option</b>				
S = Screwdriver	E = Electric	Generation	(RPM)	Q = 1/4" Hex				
<b>Configuration</b>	<b>Torque Capacity</b>	<b>Free Speed</b>	<b>Spindle Option</b>					
L = Lever Start	(max. approx.)	(RPM)	Q = 1/4" Hex					
P = Push-To-Start	15 = 15 in.-lbs.	03 = 300	Quick-Change					
T = Trigger Start	26 = 26 in.-lbs.	07 = 700	1S5 = Angle					
	40 = 40 in.-lbs.	10 = 1,000	2S3 = Angle					
		12 = 1,200	2S5 = Angle					
		20 = 2,000						

#### Low Torque (Requires Controller)

- Power: 24V DC From Controller
- Cable Length: 5 ft. Straight
- Sound: 65 dBA
- Reversible: Yes

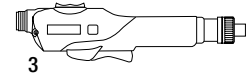

<b>S</b>	<b>L</b>	<b>E</b>	<b>01</b>	<b>A</b>	<b>-</b>	<b>09</b>	<b>-</b>	<b>Q</b>	<b>-</b>	<b>C</b>
<b>Tool</b>	<b>Type</b>	<b>Tool</b>	<b>Spindle Option</b>	<b>Clean Room</b>						
S = Screwdriver	E = Electric	Generation	Q = 1/4" Hex	Certification						
<b>Configuration</b>	<b>Torque Capacity</b>	<b>Free Speed</b>	Quick-Change	C = Class 100						
L = Lever Start	(max. approx.)	(RPM)	W = .16 Hex	Quick-Change						
	01 = 1 in.-lbs.	07 = 700	Quick-Change							
	04 = 4 in.-lbs.	09 = 900								
	10 = 10 in.-lbs.	10 = 1,000								

#### Controller (Used With Low Torque Models)

- Power: 115V AC
- Cable Length: 9.5 ft. Straight
- Speed Control: Yes – Variable
- Soft Start: Yes – Variable

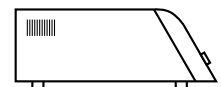

<b>SEC</b>	<b>24</b>	<b>N</b>
<b>Control Base</b>	<b>Tool Voltage</b>	<b>Source Voltage</b>
SEC	24 = 24V	N = 115V

#### Accessories

See Pages 38-39

- A1 = Length of tool with cord receptacle in side position.
- B1 = Length of tool with cord receptacle in top position.
- C1 = Flange Diameter  
Slanted Flange: 52mm  
Straight Flange: 46mm
- D1 = Grip Size = 39mm x 42mm

# DC Electric Screwdrivers

## SE Series Screwdrivers

### High Torque

Model No.	Free Speed rpm	Torque Range		Tool Length		Tool Length		Weight		Bit Size in.
		in.-lbs	Nm	in.	mm	in.	mm	lbs	kg	
<b>Straight Push-To-Start</b>										
				A1		B1				
SPE15B-20-Q	2000	5.0-15.0	.56-1.69	10.75	273	11.25	286	0.25	0.11	1.6
SPE15B-10-Q	1000	5.0-15.0	.56-1.69	10.75	273	11.25	286	0.25	0.11	1.6
SPE26B-12-Q	1200	11.0-26.0	1.24-2.94	10.75	273	11.25	286	0.25	0.11	1.6
SPE26B-7-Q	700	11.0-26.0	1.24-2.94	10.75	273	10.75	273	0.25	0.11	1.6
SPE26B-3-Q	300	11.0-26.0	1.24-2.94	10.75	273	11.25	286	0.25	0.11	1.6
<b>Straight Lever Start</b>										
SLE15B-20-Q	2000	5.0-15.0	.56-1.69	10.75	273	11.25	286	0.25	0.11	1.63
SLE15B-10-Q	1000	5.0-15.0	.56-1.69	10.75	273	11.25	286	0.25	0.11	1.63
SLE26B-12-Q	1200	11.0-26.0	1.24-2.94	10.75	273	11.25	286	0.25	0.11	1.63
SLE26B-7-Q	700	11.0-26.0	1.24-2.94	10.75	273	11.25	286	0.25	0.11	1.63
SLE26B-3-Q	300	11.0-26.0	1.24-2.94	10.75	273	11.25	286	0.25	0.11	1.63
<b>Trigger Start With Pistol Attachment</b>										
STE40B-7-Q	700	18.0-40.0	2.03-4.52	10.75	273	11.25	286	0.25	0.11	1.83
<b>Push-to-Start With Pistol Attachment</b>										
SPE40B-7-Q	700	18.0-40.0	2.03-4.52	10.75	273	11.25	286	0.25	0.11	1.83

### Low Torque

Model No.	Free Speed rpm	Torque Range		Tool Length		Tool Length		Weight		Bit Size in.
		in.-lbs	Nm	in.	mm	in.	mm	lbs	kg	
<b>Straight Lever Start (Controller Required)<sup>1</sup></b>										
				A1		B1				
SLE01A-9-W	650-950	0.26-1.3	0.03-0.15	8.63	219	9.25	235	0.7	0.32	0.16
SLE04A-10-Q (C)	750-1000	0.44-4.79	0.05-0.54	8.63	219	9.25	235	0.8	0.36	0.25
SLE10A-7-Q (C)	500-700	1.74-10.44	0.20-1.18	8.63	219	9.25	235	0.8	0.36	0.25

(1) Two clutch springs are furnished to cover torque range. Tool is shipped with heavier clutch spring installed. (C) Class 100 Clean Room Models.

### Controller for Low Torque Models

Model No.	Input Voltage	Output Voltage	Weight		Size (in.) L x W x H	Soft Start	Speed Adjustment
			lbs	kg			
SEC24N	115	24	5.1	2.3	10.5 x 3.25 x 4.1	Yes	Yes

### Angle Screwdrivers

Model No.	Free Speed rpm	Torque Range		Weight		Head Length		Side to Center		Height	
		in.-lbs	Nm	lbs	kg	in.	mm	in.	mm	in.	mm
<b>1/4" Square Drive</b>											
						A		B		C	
SLE15B-10-2S5	650	6-23	.68-2.6	2.2	1.0	17.64	448	0.52	13.2	1.73	43.94
SLE26B-12-2S5	800	12-36	1.36-4.07	2.2	1.0	17.64	448	0.52	13.2	1.73	43.94
STE40B-7-2S5	450	15-56	1.69-6.33	2.2	1.0	17.64	448	0.52	13.21	1.73	43.94
<b>1/4" Female Hex head</b>											
SLE15B-10-2S3	650	6-23	.68-2.6	2.2	1.0	17.64	448	0.52	13.21	1.73	43.94
SLE26B-12-2S3	800	12-36	1.36-4.07	2.2	1.0	17.64	448	0.52	13.21	1.73	43.94
STE40B-7-2S3	450	15-56	1.69-6.33	2.2	1.0	17.64	448	0.52	13.21	1.73	43.94
<b>1/4" Square Drive Aerospace Head<sup>2</sup></b>											
SLE15B-20-1S5	1850	5-14	.56-1.58	2	0.9	17.45	443	0.33	8.38	1.47	37.34
SLE15B-10-1S5	950	4-17	.45-1.92	2	0.9	17.45	443	0.33	8.38	1.47	37.34
SLE26B-12-1S5	1100	10-26	1.13-2.94	2	0.9	17.45	443	0.33	8.38	1.47	37.34

(2) This head is designed for close quarter applications. Not intended for extensive counterclockwise use. Angle Heads can rotate 360° for application adjustment. Torque output will vary with application.

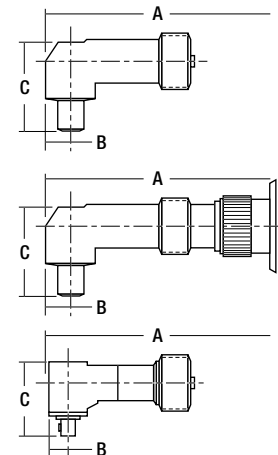

**Notes:**  
SE Series Screwdriver models are UL-listed. Your distributor or ARO representative can provide details.

# Pulse Nutsetters



ARO Pulse and ARO Pulse Plus nutrunners meet the demands of assembly operations with high speed rundown of fasteners, exceptional accuracy and consistency in torque delivery, and operator oriented design. A unique hydraulic impulse mechanism — driven by an air motor — applies torque to fasteners with a degree of control not possible in conventional tools. The result is precision fastening, with virtually no over-torquing in critical applications. Tool users benefit from the added advantages of reduced transmission of torque reaction and vibration, as well as improved balance and quiet operation.

## About Pulse Tools

The impulse mechanism operates by means of a pressure differential, which is developed through the mechanism's rotation around the drive shaft and blade.

When the pulse cycle begins, the blade maintains constant contact with the inner wall of the cylinder during the rotation of the outer mechanism.

The fluid pressure is equal on each side of the drive shaft. By the time the mechanism has rotated 90°, both the blade and the front face of the drive shaft are in contact with the inner wall of the cylinder. At this point, the fluid on the right side of the drive shaft is becoming compressed by the mechanism's rotation. The compression is what converts the inertia of the rotating mechanism into a torque impulse on the drive shaft, and ultimately to the fastener.

The degree of compression and impulse is controlled by the hex adjustment screw. The adjustment of this screw controls the amount of hydraulic fluid that is allowed to bypass the compression stage, thus increasing or decreasing the inertia transferred, and consequently the tool's torque output as well.

Air pressure can move the torque up or down. Decreasing the air pressure not only lowers the torque range but also increases the life of the pulse mechanism. Air pressure should not be lowered to any less than 50-60 psi, as levels below this can decrease the torque accuracy. Increasing the air pressure to above 100 psi is also not recommended. This can decrease the life of the mechanism and the motor.

## Motor Torque Comparison

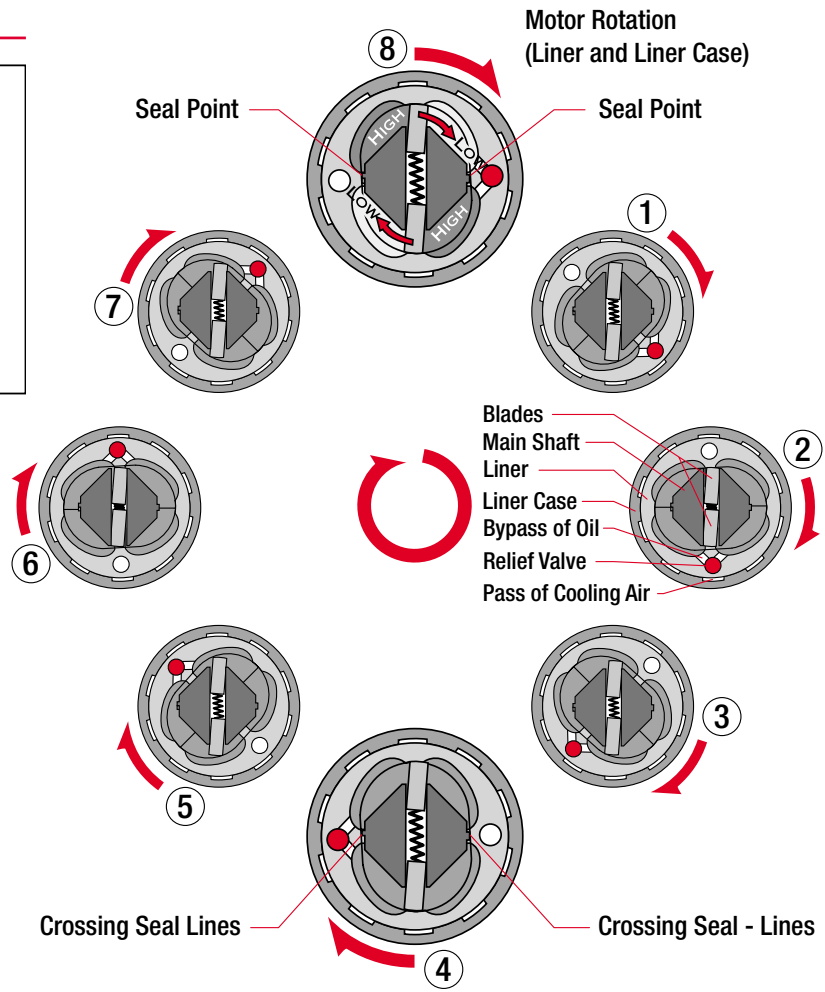
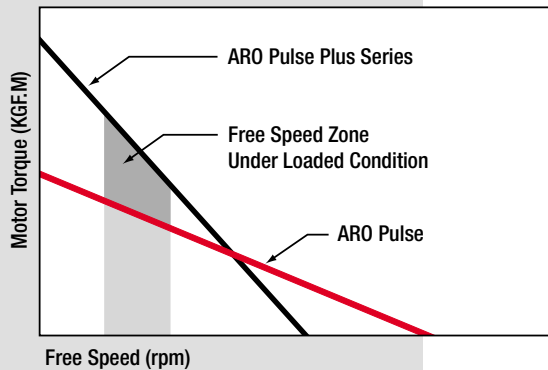

## ARO Pulse Plus Dual Lobe Motor

### Air Flow

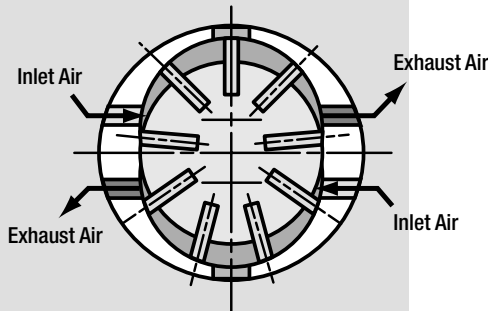

# Pulse Nutsetters

## ARO Pulse Models

ARO offers seven ARO Pulse models in pistol-grip and straight configurations, covering a torque range of 3-26 Nm. Together, they comprise a full line of precision fastening problem solvers from ARO.

### Twin-Blade Mechanism

Delivers two instantaneous, balanced pulses for higher output and faster rundown speed.

### Two Speed Trigger

Provides slow speed for precise, gradual starts as well as high speed for fast rundown.

### Excellent Power-To-Weight Ratios

For more comfortable, convenient operation.

### External Torque Adjustments

Easy external hex wrench torque adjustments, without disassembling the tool or removing it from the production line.

### Efficient Air Cooling System

For long mechanism life.



PG087A-A5



PS087A-A5

## Pulse Series Nutrunner

Model Number	Free Speed rpm	Soft Joint Torque Range			Hard Joint Torque Range			Weight lbs	Length in.	Side to Center in.	Drive Size	
		ft-lb	Nm	Kgf-cm	ft-lb	Nm	Kgf-cm				in.	cfm
PG087A-A5	9,300	3-6	4-8	41-83	3-8	4-11	4-111	1.6	5.6	0.7	1/4" Q.C.	12
PG227A-A5	10,500	6-11	8-15	83-152	14-22	19-30	194-304	2.2	6.5	0.9	1/4" Q.C.	12
PG267A-A5	9,500	10-16	14-22	138-221	16-26	22-35	221-360	2.5	7.0	0.9	1/4" Q.C.	11
PG287A-B1	9,500	12-18	16-24	138-221	18-28	24-38	249-387	2.5	7.0	0.9	3/8" SQ.	11
PS087A-A5	10,000	3-6	4-8	45-83	4-9	5-12	60-120	1.8	8.9	0.8	1/4" Q.C.	12
PS227A-A5	9,000	6-11	8-15	83-152	12-22	16-30	166-304	2.0	8.7	0.9	1/4" Q.C.	9
PS267A-A5	8,000	7-14	10-19	97-194	13-26	18-35	180-360	2.1	9.0	0.9	1/4" Q.C.	11

Note:

Torque ranges are provided as a guide only.

Actual torque output will depend on joint type, air pressure, and type of accessories used.



# Pulse Nutsetters

## ARO Pulse Plus...

### for even greater productivity.

The ARO Pulse Plus series features an innovative dual lobe and nine-vane motor, coupled with a proven two-blade pulse mechanism. This power source delivers more torque and faster rundown speeds on soft joints, and minimizes torque spikes due to inertia effects on hard joints. You can choose from eight models covering a torque range of 22-97 Nm. All feature refined ergonomics, with a more compact size, lighter weight, and easy, comfortable controls... a real plus for productivity.

The efficient packaging of the ARO Pulse Plus models achieves proper balance in the operator's hand. The rubber grip surface on the handle provides insulation from cold, and further minimizes the already low vibration levels. The forward/reverse control is easy to use for right or left-handed operators, and also allows one-handed operation. Virtually no torque reaction reaches the operator's hand... and the ARO Pulse Plus nutrunners are extremely quiet.

## External Features

### Smaller and Lighter

The new ARO Pulse Plus models are smaller and lighter, creating a more comfortable fit to the operator and therefore increasing productivity.

### New and Improved Grip

The handles of the new ARO Pulse Plus models are covered in an easy-to-grip black rubber material with special no-slip indentations. This feature requires less grip pressure and improves control.

### Minimal Vibration

Operators will also appreciate the extremely low vibration levels of these new tools.

### Easy One-Handed Forward / Reverse

The one-handed forward / reverse control allows any user easy access, increases operator comfort and saves valuable time in applications requiring a frequent change of direction. The control is positioned ideally for a right-handed operator, but can also be adjusted for optimum use by a left-handed operator.

### Tease Throttle

Two speed throttle with "tease" control provides slow speed for precise, gradual starts as well as high speed for fast rundown.

### Quiet Operation

The two-bladed pulse mechanism provides a smooth, quiet transmission of torque.

## Internal Features

### Nine-Vane Motor

Powerful, dual-lobe nine-vane motor increases torque output and provides an impressive power-to-weight ratio.

### Twin-Blade Pulse Mechanism

The twin-blade pulse mechanism delivers two instantaneous, balanced pulses for higher output torque and faster rundown speeds.

### Air Cooled Mechanism

The new ARO Pulse Plus tools feature an air-cooled mechanism, with compressed air flowing over the pulse or hydraulic mechanism to reduce heat buildup. Air cooling allows for longer service intervals and provides extended tool life.

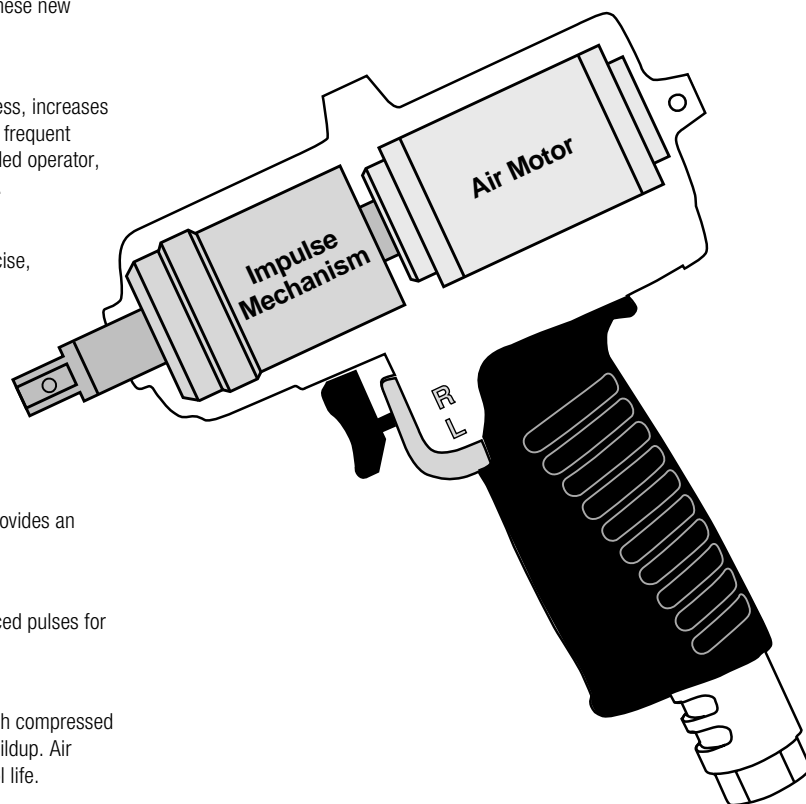
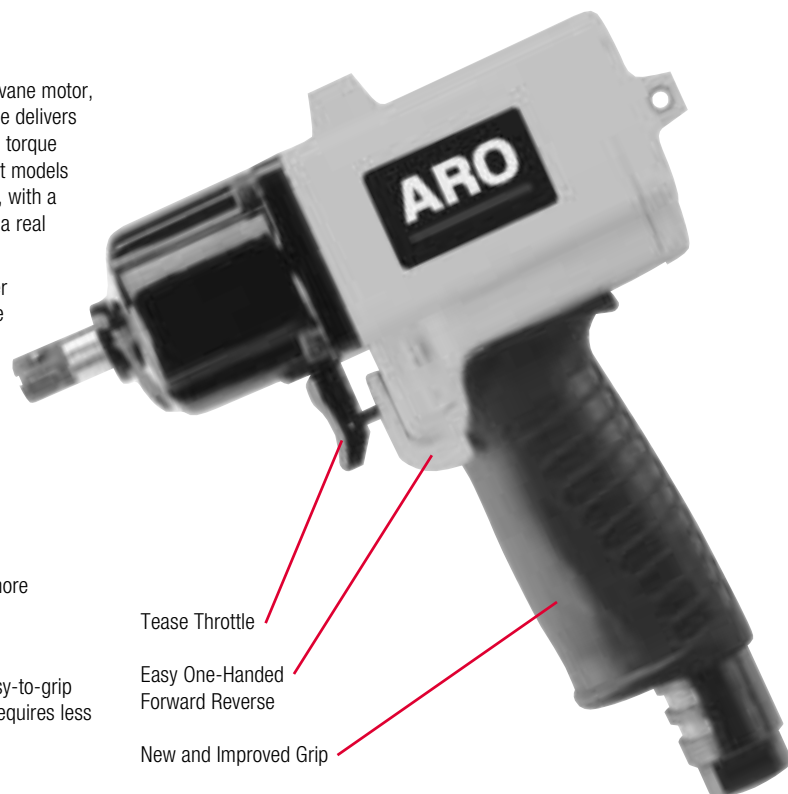

# Pulse Nutsetters

## Pulse Plus Series Nutrunner

Model Number	Soft Joint Torque Range			Soft Joint Torque Range			Speed rpm	Weight lbs	Length in.	Side to Center in.	Drive Size in.
	ft-lb	Nm	Kgf-cm	ft-lb	Nm	Kgf-cm					
PG247A-A5	16-24	20-32	202-330	17-25	23-34	239-349	8,000	2.10	5.70	1.86	1/4" Hex
PG307A-A5	19-30	25-41	257-413	20-30	27-41	275-413	6,000	2.20	6.50	1.86	1/4" Hex
PG347A-B1	16-27	22-36	220-370	19-28	26-3	270-390	8,000	2.10	5.70	1.86	3/8"
PG397A-B1	21-33	28-45	290-460	22-33	30-45	310-460	6,600	2.20	6.50	1.86	3/8"
PG537A-B1	35-52	47-70	480-710	33-50	45-68	460-690	7,000	3.10	7.00	1.96	3/8"
PG857A-D1	50-65	68-88	690-900	50-71	68-96	690-980	6,000	4.00	7.20	2.31	1/2"

Note:

Torque ranges are provided as a guide only.

Actual torque output will depend on joint type, air pressure, and type of accessories used.

## ARO Cordless Pulse Models

### Torque Range

- 6 to 14 ft.-lb.

### Accessories

- BP10P3-951-UL 1-hour Charger
- BP10P3-952-UL 90-minute Charger
- PBG147A-K2-UL 3/8" Square Drive Kit
- PBG147A-QK2-UL 1/4" Hex Quick Change Kit

### Kit Includes:

PGB147, extra battery pack (BP10P3-950), 1-hour Charger (BP10P3-951-UL) and Boot (BP10P-32).



PBG147A-A5

## Pulse Plus Series Nutrunner

Model Number	Soft Joint Torque Range			Soft Joint Torque Range			Speed rpm	Weight lbs	Length in.	Side to Center in.	Drive Size in.
	ft-lb	Nm	Kgf-cm	ft-lb	Nm	Kgf-cm					
PBG147A-A5	6-11	8-14	83-147	7-13	10-17	101-174	2,200	3.8 <sup>1</sup>	8.1	1.0	1/4" Hex
PBG147A-B1	7-12	9-16	90-160	8-14	11-19	110-190	2,200	3.8 <sup>1</sup>	8.1	1.0	3/8"

(1) Weight includes battery

Note:

Torque ranges are provided as a guide only.

Actual torque output will depend on joint type, air pressure, and type of accessories used.

# ETT Expert™ Torque Tester

## Features and Benefits

- Recommended for most hand screwdrivers, wrenches, or power tools
- Ideal for testing output torque of assembly tools in the calibration lab, repair crib, or on the production line
- Six different languages (English, French, German, Italian, Spanish, Swedish) standard on all units
- Nine units of measurement for compatibility with global standards
- Charger is equipped with different adaptors to make it easy to use in most of the world
- Four operation modes: Peak, Click, Impulse and Track modes
- High/Pass/Low LED's
- Auto and manual reset function
- Data transfer function to a PC or Printer via the RS232 port
- Diagnostics keep track of past and future calibration dates and current software release
- 8 hours of battery time under normal use
- Auto power down timer keeps unit charged longer
- Quick-Clamp mounts integrated into housing
- Quick-Disconnect plate available for convenient mounting structure
- Certificate of calibration to National Institute of Standards and Technology (NIST) included with every unit



## Torque Testers

Model	Torque Range				Accuracy FSD	Weight		Dimensions	
	Minimum in.-lbs	Nm	Maximum in.-lbs	Nm		lbs	kg	in.	mm
ETT-1	0.88	0.1	8.8	1	0.5%	5.0	2.7	9¼ x 8¼ x 2¾	213 x 238 x 70
ETT-4	3.50	0.4	35.0	4	0.5%	5.0	2.7	9¼ x 8¼ x 2¾	213 x 238 x 70
ETT-12	10.60	1.2	106	12	0.5%	5.0	2.7	9¼ x 8¼ x 2¾	213 x 238 x 70
ETT-30	26.50	3.0	265	30	0.5%	5.0	2.7	9¼ x 8¼ x 2¾	213 x 238 x 70

## ETA Unit includes:

Model No.	Item
ETT-1/ETT-4/ETT-12/ETT-30	Torque Analyzer
ETT-BC-US/ETT-BC-UK/ETT-BC-EU	Battery Charger
ETT-RA	Rundown Adaptor
ETA2-PC99	PC Connector (RS232)
ETT-CASE	Carrying Case
ETT-P7574	Operating Manual
ETA2-99	Certificate of Calibration

## Available Accessories:

Model No.	Item
ETA2-P925	Printer Connector Cable
ETT-QD	Quick-Disconnect Plate

# Screwdriver Clutches, Bits and Finders

## Screwdrivers and Nutsetters

### Positive Clutch Options

Tool Series	Bit Holder Driven Jaw Number	Drive Jaw Number	Clutch Housing Number
000 QRT's Models 8683, 8684 <sup>2</sup>	1/4" Female Hex with 25° Jaws – 37022 <sup>1</sup>	25° Jaw Assy. – 37018 <sup>1</sup>	with finder adapter – 37024 or with guide – 37026 <sup>1</sup>
	1/4" Female Hex with 90° Jaws – 36518	90° Jaw Assy. – 37020	with finder adapter – 37024 or with guide – 37026
	1/4" Sq. Drive with 25° Jaws – 38814-3	37018	37026-1
0 QRT's Models 8506, 8509, 8515, 8521 <sup>2</sup>	1/4" Female Hex with 25° Jaws – 37021 <sup>1</sup>	25° Jaw Assy. – 37017	with finder adapter – 37023 or with guide – 37025 <sup>1</sup>
	1/4" Female Hex with 90° Jaws – 36322	90° Jaw Assy. – 37019	with finder adapter – 37023 or with guide – 37025
	3/8" Sq. Drive with 25° Jaws – 38815-3	37017	37025-1
	3/8" Sq. Drive with 90° Jaws – 38815-4	37019	37025-1

(1) Standard on positive clutch models. (2) See page 10

### Adjustable Ball Clutch Options

Tool Series	Bit Holder Driven Jaw Number	Clutch Number	Clutch Housing Number
000 QRT's <sup>2</sup>	1/4" Female Hex – 36518 <sup>1</sup>	with Standard Spring Internal Adj. – 36511 <sup>1</sup> or with Heavy-Duty Spring, Internal Adj. – 36511-1	with finder adapter – 45630 or with guide – 45630 <sup>1</sup> 45630
	3/8" Sq. Drive – 38814-4		
0 QRT's <sup>2</sup>	1/4" Female Hex – 36322 <sup>1</sup>	with Standard Spring – 36310 <sup>1</sup> or with Heavy-Duty Spring – 36310-2 or with Light-Duty Spring – 36310-2	with finder adapter – 36786 or with guide – 36788 <sup>1</sup> 36788-1
	3/8" Sq. Drive – 38815-4		

(1) Standard on adjustable ball clutch models. (2) See page 10

## Bits and Finders

### Screwdrivers and Nutsetters

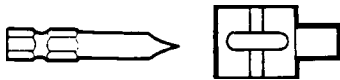

#### 1/4" Hex Shank Bladed Bits and Standard Finders

Screw Size No.	1 5/16" (49mm) Length Bits	Finder Number for		Series 20 & 50 Screwdrivers <sup>1</sup>
		Series 20 & 50 Screwdrivers <sup>1</sup>	3 1/2" (89mm) Length Bits	
1	F164	46343-1	F164	46344-1
2	F1645	46343-2	F1645	46344-2
3	XF165	46343-3	XF165	46344-3
4	XF166	46343-4	XF166	46344-4
5	XF167	46343-5	XF167	46344-5
6	XF168	46343-6	XF168	46344-6
8	XF169	46343-8	XF169	46344-8
10	XF1610	46343-10	XF1610	46344-10
12	XF16	46343-12	XF16	46344-12

(1) Includes 46325 Finder Spring.



#### 1/4" Hex Shank Allen Head Drivers

Hex Size in.	1 5/16" (49mm) Length Bits	Adapter/Guide No.
		Series 20 & 50 Screwdrivers <sup>1</sup>
3/32	HX133	46884(-1)
1/8	HX134	46884(-1)
5/32	HX135	46884(-1)
3/16	HX136	46884(-1)
7/32	HX137	46884(-1)
1/4	HX138	46884(-1)
9/64	HX1345	46884(-1)

(1) 46884 for use with direct drive and automatic shut-off clutches.  
46884-1 for use with adjustable ball and positive clutches.



#### 1/4" Hex Shank Phillips Bits

Screw Point Size	1 5/16" (49mm) Length Bits	2 3/4" (70mm) Length Bits	Adapter/Guide No.
			Series 20 & 50 Screwdrivers <sup>1</sup>
1	XP161	XP221	46884(-1)
2	XP162	XP222	46884(-1)
3	XP163	XP223	46884(-1)

(1) 46884 for use with direct drive and automatic shut-off clutches.  
46884-1 for use with adjustable ball and positive clutches.



#### 1/4" Hex Shank Integral Bit and Finder

Screw Size No.	3 23/32" (94mm) Length Bits	Adapter/Guide No.
		Series 20 & 50 Screwdrivers <sup>1</sup>
5	XR306	46884(-1) <sup>1</sup>
6	XR308	46884(-1) <sup>1</sup>
8	XR3010	46884(-1) <sup>1</sup>
10	XR3012	46884(-1) <sup>1</sup>

(1) 46884 for use with direct drive and automatic shut-off clutches.  
46884-1 for use with adjustable ball and positive clutches.

# Screwdrivers and Nutsetters

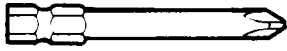

### 1/4" Hex Shank Reed and Prince Bits

Screw Point Size	1 <sup>15</sup> / <sub>16</sub> " (49mm) Lengh Bits	Adapter/Guide No. Series 20 & 50 Screwdrivers <sup>1</sup>
1	XP161	46884(-1)

(1) 46884 for use with direct drive and automatic shut-off clutches.  
46884-1 for use with adjustable ball and positive clutches.



### 1/4" Hex Shank Pozidriv Bits

Screw Point Size	1 <sup>15</sup> / <sub>16</sub> " (49mm) Length Bits	Adapter/Guide No. Series 20 & 50 Screwdrivers <sup>1</sup>
1	XP161	46884(-1)
2	XP162	46884(-1)
3	XP163	46884(-1)

(1) 46884 for use with direct drive and automatic shut-off clutches.  
46884-1 for use with adjustable ball and positive clutches.

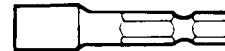

### 1/4" Hex Shank Bit Holders

Apex Mag. Bit Holder No.	Length	Adapter/Guide No. Series 20 & 50 Screwdrivers
40259	2 <sup>31</sup> / <sub>32</sub> " (75mm)	46885(-1)

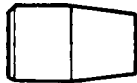

### Sq. Drive Adapters for 5/16" Sq. Bit Inserts<sup>1</sup>

Adapter No.	Sq. Drive Mounting Size in.	Sq. Drive Size in.
2U-812	3/8	5/16

(1) 46884, 46885, 46886 for use with direct drive and automatic shut-off clutches.  
46884-1, 46885-1, 46886-1 for use with adjustable ball and positive clutches.



### 1/4" Hex Bit Inserts

Screw Point Size	Phillips 1" (25mm) Length Bits	Pozidriv 1" (25mm) Length Bits
1	XPB07	XPZB071
2	XPB07	XPZB072
3	XPB073	XPZB073

## Accessories

# SE Series Screwdrivers and Nutsetters

### Electric Accessories

#### Screwdriver Bits for SLE01A-9-W

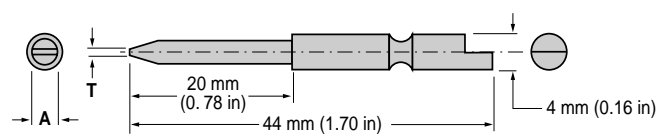
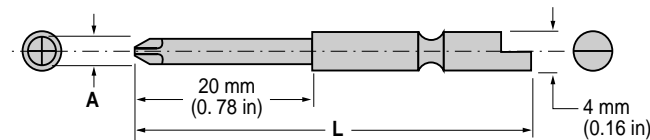

#### Phillips Head for Phillips Head Screws

Bit (Qty 10) Part No.	Point Size	"A" - Dia. in.	mm	Dim. L in.	mm	Screw Size Range
DLB2120-10	0	.071	1.8	1.7	38	0 to 1
DLB2121-10	0	.071	1.8	2.5	64	0 to 1
DLB2122-10	00	.079	2.0	1.7	38	00 to 0
DLB2123-10	00	.079	2.0	2.5	64	00 to 0
DLB2124-10	0	.098	2.5	1.7	38	0 to 1
DLB2125-10	0	.098	2.5	2.5	64	0 to 1
DLB2126-10	1	.118	3.0	1.7	38	2 to 4
DLB2127-10	1	.118	3.0	2.5	64	2 to 4
DLB2128-10	1	.157	4.0	1.7	38	2 to 4
DLB2129-10	1	.157	4.0	2.5	64	2 to 4
DLB2130-10	2	.157	4.0	1.7	38	5 to 10
DLB2131-10	2	.157	4.0	2.5	64	5 to 10
DLB2132-10	3	.236	6.0	1.7	38	10 to 1/4

#### Slotted Head for Slotted Head Screws

Bit (Qty 10) Part No.	Dim. T in.	"A" - Dia. in.	mm	Screw Size Range
DLB2220-10 <sup>1</sup>	.012	.079	2.0	00 to 0
DLB2221-10 <sup>1</sup>	.012	.098	2.5	00 to 0
DLB2222-10 <sup>1</sup>	.016	.118	3.0	0 to 2
DLB2223-10 <sup>1</sup>	.020	.157	4.0	2 to 4
DLB2224-10 <sup>1</sup>	.026	.197	5.0	3 to 5

(1) Only Phillips Bits are meant to be used with Vacuum Pickup Systems.  
Slotted Bits may sometimes be used by undersizing the Bits for the Vacuum Sleeves.

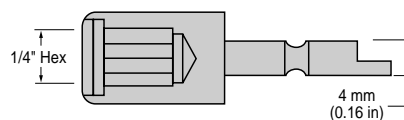

• Insert Bit Holder Adapter (DLW-4100)  
For use with 1/4" Hex Insert Bits



# SE Series Screwdrivers and Nutsetters

## Hexagon - Male and Female

Part No.	Dim. H/B		Dim. L		Screw Size	
	in.	mm	in.	mm	in.	mm
DLB2321-10	0.06	1.5	1.7	44	0.12	3
DLB2322-10	0.08	2	1.7	44	0.16	4
DLB2323-10	0.12	3	1.7	44	0.24	6
DLB2324-10	0.16	4	1.7	44	0.31	8
DLB2420-10	0.09	2.3	1.7	44	-	-
DLB2421-10	0.10	2.5	1.7	44	-	-
DLB2422-10	0.12	3	1.7	44	-	-
DLB2423-10	0.16	4	1.7	44	0.08	2
DLB2424-10	0.18	4.5	1.7	44	0.09	2.3
DLB2425-10	0.20	5	1.7	44	0.01	2.6
DLB2426-10	0.22	5.5	1.7	44	0.12	3

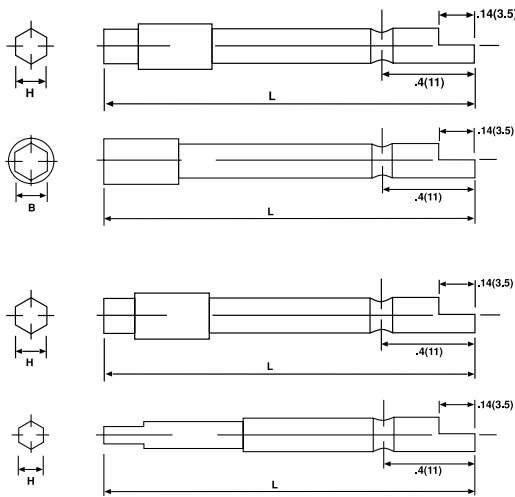

## Vacuum Pickup Sleeves (For use with SLE04A-10-QC & SLE10A-7-QC)

Bit Part No.	Inside Dia.		Outside Dia.	
	in.	mm	in.	mm
DLS2120	.079	2.0	.138	3.5
DLS2121	.087	2.2	.138	3.5
DLS2122	.098	2.5	.138	3.5
DLS2123	.106	2.7	.138	3.5
DLS2124	.122	3.1	.177	4.5
DLS2125	.130	3.3	.177	4.5
DLS2126	.138	3.5	.177	4.5
DLS2127	.146	3.7	.177	4.5
DLS2128	.158	4.0	.212	5.5
DLS2129	.165	4.2	.212	5.5
DLS2130	.177	4.5	.212	5.5
DLS2131	.185	4.7	.212	5.5
DLS2132	.201	5.1	.256	6.5
DLS2133	.209	5.3	.256	6.5
DLS2134	.221	5.6	.256	6.5
DLS2135	.240	6.1	.276	7.0

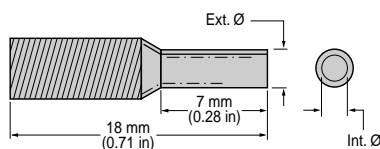

## SE Electric Accessories

### Attachable Pistol-Grip Handle (EP4007N-48)

For use with all high torque models. Lever and push to start.



Attachable Pistol-Grip Handle

### Torque Adjusting Wrench (EP4007N-516)

Used to externally adjust the high torque models without removing the flange.



Torque Adjusting Wrench

### Digital Counter (EC24-DC)

Used with low torque models. Digital display shows number of cycles. Includes modem cord to attach to controller.

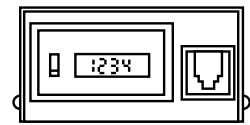

Digital Counter

### Suspension Bails

- High Torque
  - A-Vertical – EP4007N-365
  - B-Horizontal – EP4007N-366
- Low Torque Vertical – EL0109B-365

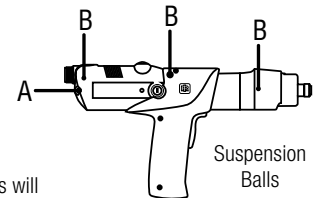

Suspension Balls

### Calibration / Maintenance Labels (EP4007N-302)

Adhesive labels to be placed on tools. This will help with scheduling maintenance or calibration.

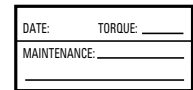

Calibration / Maintenance Labels

### Low Profile Flange (EP4007N-123)

Smaller dimension flange (standard for Pistol and Angle models).

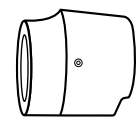

Low Profile Flange

### Mounting Bracket (EC24-MB)

Used to mount controller.

### Spring (Low Torque) (VDS-511)

- 1.5-7 in.-lbs. – EP1510
- 2.0-9 in.-lbs. – EP1520

### Additional Cords (High Torque)

- 6 ft. Coiled – EP4007N-239-C6A
- 12 ft. Straight – EP4007N-239-12A
- 8 ft. Straight – EP4007N-239-8A (Standard)
- 25 ft. Straight – EP4007N-239-25A

### Torque Adjustment Cover

- For use on VersaTec low torque models
- EL0410BC-46

# Drills and Tappers



## Drill Selection

Making sure you have the right tool for the right job is essential for effective drilling with consistent quality. Selecting a portable air drill involves two primary considerations:

- 1 The material and hardness.
- 2 The size of the hole to be drilled.

In general, a smaller, high-speed drill is most appropriate for smaller holes and softer materials, such as wood or aluminum. For larger holes and harder materials, a more powerful tool with slower speeds is required to prevent stalling and bit damage.

## Getting The Most From Your Drill:

To maximize your drill's output, you must use the right accessories. Always keep in mind that the force you apply on the drill will affect how fast the tool drills.

The more you push down, the slower the tool will work. The most you ever want your drill to slow down is 25 to 50 percent of its free speed, so be aware of the amount of pressure you are applying.

## Model Identification Guide Series 20/50

Example: DG021B-33-A

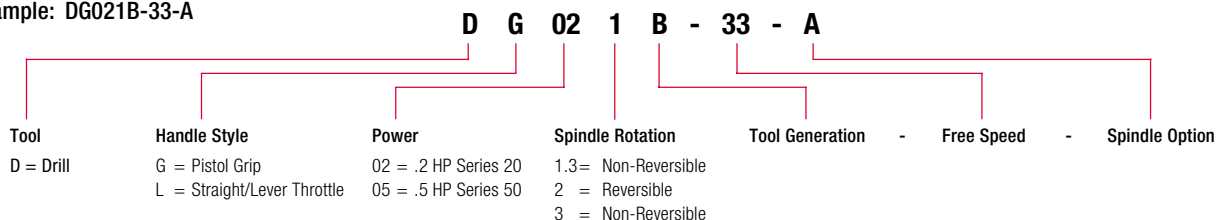

## Recommended Cutting Speed Range – RPM

This chart lists the recommended surface speeds for popular materials with suggested spindle speeds for various hole sizes. These recommendations are intended only as a guide for determining appropriate drill size and speed. Proper tool selection for a specific application must also take into account the operator,

the type of bit used, the amount of compressed air available, as well as other factors. Where there is a choice between ARO Series 20 and 50 drills of about the same speed, final selection is made by preference of a smaller, lighter drill, or a more powerful model to maintain speed under load.

Material	S.F.M. <sup>1</sup>	Hole Diameter							
		1/16"	1/8"	3/16"	1/4"	5/16"	3/8"	7/16"	1/2"
		1.5 mm	3 mm	5 mm	6 mm	8 mm	9.5 mm	11 mm	13 mm
Steel Alloy (300-400 Brinell)	20-30	1250-1800	600-900	400-600	300-450	250-350	200-300	175-250	150-225
Stainless Steel / Cast Iron (hard)	30-40	1800-2500	900-1200	600-800	450-600	350-500	300-400	250-350	225-300
Steel Forgings	40-50	2500-3100	1200-1500	800-1000	600-750	500-600	400-500	350-425	300-400
Tool Steel (Annealed .90-1.20 Carbon)	50-60	3100-3700	1500-1800	1000-1200	750-900	600-700	500-600	425-525	400-450
Steel (.40-.50 Carbon)	70-80	4300-5000	2100-2500	1400-1600	1050-1200	850-1000	700-800	600-700	525-600
Cast Iron (med.-hard)	70-100	4300-6000	2100-3000	1400-2000	1000-1500	850-1200	700-1000	600-900	500-800
Bronze, High-Tensile Strength	70-150	4300-9000	2100-4500	1400-3000	1000-2300	850-1800	700-1530	600-1300	500-1200
Malleable Iron	80-90	5000-5500	2500-2800	1600-1800	1200-1400	950-1100	800-900	700-800	600-700
Mild Steel (.20-.30 Carbon)	80-110	5000-6700	2500-3400	1600-2300	1200-1700	950-1350	800-1150	700-1000	600-850
Cast Iron (soft) / Plastic	100-150	6000-9000	3000-4500	2000-3000	1500-2300	1200-1800	1000-1530	900-1300	800-1200
Aluminum / Brass / Bronze	200-300	12000-18000	6000-9000	4000-6000	3000-4500	2400-3700	2000-3000	1700-2600	1500-2300
Magnesium	250-400	15500-25000	7500-12000	5000-12000	3800-6100	3000-4900	2500-4000	2200-3500	1900-3000
Fiberglass / Wood	300-400	18000-25000	9000-12000	6000-8200	4600-6100	3700-4900	3000-4000	2600-3500	2300-3000

Note: Actual drilling or cutting rpm will be approximately 75% of the rated free speed of a tool. (1) SFM - Surface feet per minute

# Pistol Grip Drills

## Drills and Tappers

**Torque Output: 0.2 to 29 ft-lbs (0.3 to 39 Nm)**  
**Power: 0.25 hp / 0.55 hp (0.34 / 0.73 kW)**



DG021B-33-A



DG051B-15-B

### Pistol Grip Drills

Non Reversible Models	Free Speed rpm	Stall Torque ft-lbs	Stall Torque Nm	Reversible Models	Free Speed rpm	Stall Torque ft-lbs	Stall Torque Nm	Spindle Offset in.	Spindle Offset mm	Length in.	Length mm	Weight lbs	Weight kg	Spindle Thread Male	@ Free Speed Air Cons. cfm	@ Free Speed Sound Level dB(A)	
<b>Series 20</b>																	
DG021B-220-(-)	22,000	0.2	0.3	DG022B-170-(-)	17,000	0.2	0.3	0.66	17	5.7	146	1.5	0.7	3/8"-24	15	7	76
• DG021B-64-(-)	6,400	0.7	1.0	DG022B-50-(-)	5,000	0.6	0.8	0.66	17	5.7	146	1.5	0.7	3/8"-24	15	7	76
• DG021B-33-(-)	3,300	1.3	2.0	• DG022B-26-(-)	2,600	1.2	1.6	0.66	17	5.7	146	1.5	0.7	3/8"-24	15	7	76
• DG021B-19-(-)	1,900	2.3	3.0	DG022B-15-(-)	1,500	2.1	2.8	0.66	17	6.1	155	1.6	0.7	3/8"-24	15	7	76
DG021B-10-(-)	1,000	4.5	6.0	• DG022B-8-(-)	800	4.1	5.5	0.66	17	6.1	155	1.6	0.7	3/8"-24	15	7	76
DG021B-5-(-)	500	8.9	12.0	DG022B-4-(-)	400	8.0	11.0	0.66	17	6.1	155	1.6	0.7	3/8"-24	15	7	76
<b>Series 50</b>																	
DG051B-180-(-)	18,000	0.7	1.0	DG052B-170-(-)	17,000	0.6	0.8	0.9	22	6.8	171	2.3	1.1	3/8"-24	25	12	78
DG051B-52-(-)	5,200	2.4	3.0	DG052B-50-(-)	5,000	2.0	2.7	0.9	22	6.8	171	2.3	1.1	3/8"-24	25	12	78
• DG051B-33-(-)	3,300	3.5	5.0	• DG052B-30-(-)	3,000	2.8	3.8	0.9	22	6.8	171	2.3	1.1	3/8"-24	25	12	78
DG051B-27-(-)	2,700	4.1	5.5	DG052B-25-(-)	2,500	3.3	4.8	0.9	22	6.8	171	2.3	1.1	3/8"-24	25	12	78
• DG051B-15-(-)	1,500	8.0	11.0	• DG052B-15-(-)	1,500	6.4	8.7	0.9	22	7.5	189	2.7	1.2	3/8"-24	25	12	78
• DG051B-11-(-)	1,100	9.5	13.0	• DG052B-10-(-)	1,000	7.6	10.0	0.9	22	7.5	189	2.7	1.2	3/8"-24	25	12	78
DG051B-6-(-)	600	17.0	23.0	• DG052B-6-(-)	600	14.0	19.0	0.9	22	7.5	189	2.7	1.2	3/8"-24	25	12	78
• DG051B-4-(-)	400	29.0	39.0	DG052B-4-(-)	400	23.0	31.0	0.9	22	7.5	189	2.7	1.2	3/8"-24	25	12	78

• Most popular model.  
 Air Inlet – 1/4" NPTF Recommended Air Pressure – 90 PSI (6.2 bar) Recommended Hose Size – 5/16" (8 mm) I.D.

### Ordering Information

Specify the Base Model Number having the desired speed from the specification chart above. Add the appropriate Dash Letter to indicate the desired spindle option from the chart below.

Example: DG021B-19-A

### Spindle Options

Dash Letter	Spindle Option	Series 20 Models Free Speed							Series 50 Models Free Speed							
		Non-Reversible	500	1000	1900	3300	6400	22000	400	600	1100	1500	2700	3300	5200	18000
A	1/4" (6 mm) Cap. Chuck	•	•	•	•	•	•	•	•	•	•	•	•	•	•	•
B	3/8" (9 mm) Cap. Chuck	•	•	•	NR	NR	NR	•	•	•	•	•	•	•	•	NR
L <sup>1</sup>	3/8" (9 mm) Cap. Keyless Chuck	NR	•	•	NR	NR	NR	NR	NR	•	•	•	•	•	•	NR
P	3/8" – 24 Male Thread	•	•	•	•	•	•	•	•	•	•	•	•	•	•	•
Q	1/4" Hex Quick-Change Chuck	•	•	•	•	•	NR	•	•	•	•	•	•	•	•	NR

• Indicates the model speeds on which a particular spindle option is available. NR indicates that the spindle option is not recommended for a particular speed tool.  
 (1) Note: Keyless Chuck is only available on reversible models.

# Straight / Lever Throttle Drills

## Drills and Tappers

**Torque Output: 0.2 to 29 ft-lbs (0.3 to 39 Nm)**  
**Power: 0.25 hp / 0.55 hp (0.34 / 0.73 kW)**



DL021B-19-A



DL051B-33-B

### Straight / Lever Throttle Drills

Non Reversible Models	Free Speed rpm	Stall Torque ft-lbs	Stall Torque Nm	Reversible Models	Free Speed rpm	Stall Torque ft-lbs	Stall Torque Nm	Spindle Offset in.	Spindle Offset mm	Length in.	Length mm	Weight lbs	Weight kg	Spindle Thread Male	Air Consp. cfm	Air Consp. L/s	@ Free Speed Sound Level dB(A)
<b>Series 20</b>																	
DL021B-220-(-)	22,000	0.2	0.3	-	-	-	-	0.6	15	7.2	182	1.0	0.5	3/8"-24	15	7	76
• DL021B-64-(-)	6,400	0.7	1.0	-	-	-	-	0.6	15	7.2	182	1.0	0.5	3/8"-24	15	7	76
• DL021B-33-(-)	3,300	1.3	2.0	DL022B-26-(-)	2,600	1.2	1.6	0.6	15	7.2	182	1.0	0.5	3/8"-24	15	7	76
• DL021B-19-(-)	1,900	2.3	3.0	DL022B-15-(-)	1,500	2.1	2.8	0.6	15	7.5	191	1.1	0.5	3/8"-24	15	7	76
• DL021B-10-(-)	1,000	4.5	6.0	DL022B-8-(-)	800	4.1	5.5	0.6	15	7.5	191	1.1	0.5	3/8"-24	15	7	76
• DL021B-5-(-)	500	8.9	12.0	DL022B-4-(-)	400	8.0	11.0	0.6	15	7.5	191	1.1	0.5	3/8"-24	15	7	76
<b>Series 50</b>																	
• DL051B-180-(-)	18,000	0.7	1.0	-	-	-	-	0.9	22	8.6	218	2.2	1.0	3/8"-24	25	12	78
• DL051B-52-(-)	5,200	2.4	3.0	-	-	-	-	0.9	22	8.6	218	2.2	1.0	3/8"-24	25	12	78
• DL051B-33-(-)	3,300	3.5	5.0	DL052B-30-(-)	3,000	2.8	3.8	0.9	22	8.6	218	2.2	1.0	3/8"-24	25	12	78
• DL051B-27-(-)	2,700	4.1	5.5	DL052B-25-(-)	2,500	3.3	4.8	0.9	22	8.6	218	2.2	1.1	3/8"-24	25	12	78
• DL051B-15-(-)	1,500	8.0	11.0	DL052B-15-(-)	1,500	6.4	8.7	0.9	22	9.3	236	2.5	1.1	3/8"-24	25	12	78
• DL051B-11-(-)	1,100	9.5	13.0	DL052B-10-(-)	1,000	7.6	10.0	0.9	22	9.3	236	2.5	1.1	3/8"-24	25	12	78
• DL051B-6-(-)	600	17.0	23.0	DL052B-6-(-)	600	14.0	19.0	0.9	22	9.3	236	2.5	1.1	3/8"-24	25	12	78
• DL051B-4-(-)	400	29.0	39.0	DL052B-4-(-) <sup>1</sup>	400	23.0	31.0	0.9	22	9.3	236	2.5	1.1	3/8"-24	25	12	78

• Most popular model.

Air Inlet – 1/4" NPTF Recommended Air Pressure – 90 PSI (6.2 bar) Recommended Hose Size – 5/16" (8 mm) I.D.

### Ordering Information

Specify the Base Model Number having the desired speed from the specification chart above. Add the appropriate Dash Letter to indicate the desired spindle option from the chart below.

Example: DL051B-33-B

### Spindle Options

Dash Letter	Spindle Option	Series 20 Models Free Speed							Series 50 Models Free Speed						
		Non-Reversible	500	1000	1900	3300	6400	22000	400	600	1100	1500	2700	3300	5200
		Reversible	400	800	1500	2600		400	600	1000	1500	2500	3000		
A	1/4" (6 mm) Cap. Chuck	•	•	•	•	•	•	•	•	•	•	•	•	•	•
B	3/8" (9 mm) Cap. Chuck	•	•	•	NR	NR	NR	•	•	•	•	•	•	•	NR
J	3/8" Square Drive	•	•	•	•	•	NR	•	•	•	•	•	•	•	NR
K	1/2" Square Drive	•	•	•	•	•	NR	•	•	•	•	•	•	•	NR
P	3/8" – 24 Male Thread	•	•	•	•	•	•	•	•	•	•	•	•	•	•
Q	1/4" Hex Quick-Change Chuck	•	•	•	•	•	NR	•	•	•	•	•	•	•	NR

• Indicates the model speeds on which a particular spindle option is available. NR indicates that the spindle option is not recommended for a particular speed tool.

# Right-Angle Drills Drills and Tappers

**Torque Output: 0.3 to 24 ft-lbs (0.4 to 33 Nm)**  
**Power: 0.25 hp / 0.55 hp (0.34 / 0.73 kW)**



DR021B-50-A



DR021B-26-P



DR051B-36-A



DR051B-4-P

## Right-Angle Drills

Non-Reversible Models	Free Speed rpm	Stall Torque		Spindle Offset		Angle Head Heights				Tool Length		Tool Weight		Air Inlet Female	@ Free Speed		
		ft-lbs	Nm	in.	mm	w/Chuck	w/Collet	in.	mm	in.	mm	lbs	kg		Air Cons. cfm	L/s	Sound Level dB(A)
<b>Series 20</b>																	
DR021B-170-(-)	17,000	0.3	0.4	0.6	15	3.5	89	1.625	41.3	8.7	221	1.5	0.7	1/4" NPT	15	7	78
DR021B-50-(-)	5,000	1.0	1.3	0.6	15	3.5	89	1.625	41.3	8.7	221	1.5	0.7	1/4" NPT	15	7	78
• DR021B-26-(-)	2,600	1.9	2.6	0.6	15	3.5	89	1.625	41.3	8.7	221	1.5	0.7	1/4" NPT	15	7	78
DR021B-15-(-)	1,500	3.4	4.6	0.6	15	3.5	89	1.625	41.3	9.1	231	1.6	0.75	1/4" NPT	15	7	78
DR021B-7-(-)	700	6.6	8.9	0.6	15	3.5	89	1.625	41.3	9.1	231	1.6	0.75	1/4" NPT	15	7	78
<b>Series 50</b>																	
DR051B-125-(-)	12,500	0.8	1.1	0.6	15	3.5	89	1.625	41.3	9.8	249	2.5	1.1	1/4" NPT	25	12	78
• DR051B-36-(-)	3,600	2.9	4.0	0.6	15	3.5	89	1.625	41.3	9.8	249	2.5	1.1	1/4" NPT	25	12	78
DR051B-28-(-)	2,800	3.7	5.0	0.6	15	3.5	89	1.625	41.3	9.8	249	2.5	1.1	1/4" NPT	25	12	78
DR051B-19-(-)	1,900	5.5	7.5	0.6	15	3.5	89	1.625	41.3	9.8	249	2.5	1.1	1/4" NPT	25	12	78
DR051B-11-(-)	1,100	9.8	13.0	0.6	15	3.5	89	1.625	41.3	10.4	263	2.8	1.2	1/4" NPT	25	12	78
DR051B-7-(-)	700	16.0	22.0	0.6	15	3.5	89	1.625	41.3	10.4	263	2.8	1.2	1/4" NPT	25	12	78
DR051B-4-(-)	400	24.0	33.0	0.6	15	3.5	89	1.625	41.3	10.4	263	2.8	1.2	1/4" NPT	25	12	78

• Most popular model. Air Inlet – 1/4" NPTF Recommended Air Pressure – 90 PSI (6.2 bar) Recommended Hose Size – 5/16" (8 mm) I.D.

## Ordering Information

Specify the Base Model Number having the desired speed from the specification chart above. Add the appropriate Dash Letter to indicate the desired spindle option from the chart below.

**Example: DR021B-26-A**

### Spindle Options

Dash Letter	Spindle Option	Series 20 Models Free Speed					Series 50 Models Free Speed							
		700	1500	2600	5000	17000	400	1100	1900	2800	3600	12500	3000	
A	1/4" (6 mm) Chuck	•	•	•	•	•	•	•	•	•	•	•	•	•
B	3/8" (9 mm) Chuck	-	-	-	-	-	•	•	•	•	•	•	•	
C	3/16" (4.8 mm) Collet <sup>1</sup>	•	•	•	•	-	-	-	-	-	-	-	-	
P	3/8" – 24 Male Thread	•	•	•	•	•	•	•	•	•	•	•	•	
T	1/4" -28 Female Thread	•	•	•	•	•	NR	•	•	•	•	•	-	

• Indicates the model speeds on which a particular spindle option is available.

(1) Collet has a 9/32 – 40 male thread. Other size collets may be substituted for standard. See Collet 43497-(-) below.

### Series 43497-(-) One Piece Collets

Size No.	Dash No.	Size No.	Dash No.	Size No.	Dash No.	Size No.	Dash No.	Size No.	Dash No.	Size No.	Dash No.	Size No.	Dash No.	Size No.	Dash No.	Size No.	Dash No.	Size No.	Dash No.
7	5.1 -7	14	4.6 -14	21	4.0 -21	28	3.5 -28	35	2.7 -35	42	2.3 -42	49	1.85 -49	56	1.18 -56	3/32	2.4	-163	
8	5.0 -8	15	4.5 -15	22	3.9 -22	29	3.4 -29	36	2.7 -36	43	2.2 -43	50	1.77 -50	57	1.09 -57	7/64	2.77	-164	
9	4.9 -9	16	4.4 -16	23	3.9 -23	30	3.2 -30	37	2.6 -37	44	2.1 -44	51	1.7 -51	58	1.06 -58	1/8	3.1	-165	
10	4.9 -10	17	4.3 -17	24	3.8 -24	31	3.0 -31	38	2.5 -38	45	2.0 -45	52	1.6 -52	59	1.0 -59	9/64	3.6	-166	
11	4.8 -11	18	4.3 -18	25	3.7 -25	32	2.9 -32	39	2.5 -39	46	2.0 -46	53	1.5 -53	60	1.0 -60	5/32	3.9	-167	
12	4.8 -12	19	4.3 -19	26	3.7 -26	33	2.8 -33	40	2.4 -40	47	1.99 -47	54	1.39 -54	1/16	1.58 -161	11/64	4.3	-168	
13	4.7 -13	20	4.0 -20	27	3.6 -27	34	2.8 -34	41	2.4 -41	48	1.9 -48	55	1.9 -55	5/64	1.98 -162	3/16	4.76	-169	



# Drills and Tappers

Torque Output: 0.7 to 3.8 ft-lbs (0.9 to 5.2 Nm)

Power: 0.25 hp / 0.55 hp (0.34 / 0.73 kW)



DR023B-21-C



DA023B-37-D



DR053B-41-T



DA053B-27-D

## Aircraft Drills

Non-Reversible Models	Free Speed rpm	Stall Torque		Spindle Offset		Angle Head Heights w/Collet w/Female Thd				Tool Length		Tool Weight		Air Inlet Female	@ Free Speed		
		ft-lbs	Nm	in.	mm	in.	mm	in.	mm	in.	mm	lbs	kg		Air Consp. cfm	L/s	Sound Level dB(A)
<b>Series 20 with 90° Angle</b>																	
DR023B-73-(-)	7,300	0.7	0.9	0.325	8.3	1.4	36	1.1	28	9.5	241	1.4	0.6	1/4" NPT	15	7	78
DR023B-37-(-)	3,700	1.3	1.8	0.325	8.3	1.4	36	1.1	28	9.5	241	1.4	0.6	1/4" NPT	15	7	78
• DR023B-21-(-)	2,100	2.4	3.2	0.325	8.3	1.4	36	1.1	28	10.0	254	1.5	0.7	1/4" NPT	15	7	78
• DR023B-11-(-)	1,100	4.6	6.2	0.325	8.3	1.4	36	1.1	28	10.0	254	1.6	0.7	1/4" NPT	15	7	78
DR023B-5-(-)	500	8.9	12.0	0.325	8.3	1.4	36	1.1	28	10.0	254	1.5	0.7	1/4" NPT	15	7	78
<b>Series 20 with 45° Angle</b>																	
DA023B-37-(-)	3,700	1.3	1.8	0.325	8.3	1.7	44	1.6	41	9.9	251	1.4	0.6	1/4" NPT	15	7	78
DA023B-21-(-)	2,100	2.4	3.2	0.325	8.3	1.7	44	1.6	41	10.4	264	1.5	0.7	1/4" NPT	15	7	78
DA023B-11-(-)	1,100	4.6	6.2	0.325	8.3	1.7	44	1.6	41	10.4	264	1.5	0.7	1/4" NPT	15	7	78
DA023B-5-(-)	500	8.9	12.0	0.325	8.3	1.7	44	1.6	41	10.4	264	1.5	0.7	1/4" NPT	15	7	78
<b>Series 50 with 90° Angle</b>																	
DR053B-52-(-)	5,200	2.0	2.7	0.325	8.3	1.4	36	1.1	28	10.8	274	2.4	1.1	1/4" NPT	25	12	78
DR053B-41-(-)	4,100	2.5	3.4	0.325	8.3	1.4	36	1.1	28	10.8	274	2.4	1.1	1/4" NPT	25	12	78
DR053B-27-(-)	2,700	3.8	5.2	0.325	8.3	1.4	36	1.1	28	10.8	274	2.4	1.1	1/4" NPT	25	12	78
<b>Series 50 with 45° Angle</b>																	
DA053B-52-(-)	5,200	2.0	2.7	0.325	8.3	2.0	50	1.9	48	11.2	285	2.4	1.1	1/4" NPT	25	12	78
DA053B-41-(-)	4,100	2.5	3.4	0.325	8.3	2.0	50	1.9	48	11.2	285	2.4	1.1	1/4" NPT	25	12	78
DA053B-27-(-)	2,700	3.8	5.2	0.325	8.3	2.0	50	1.9	48	11.2	285	2.4	1.1	1/4" NPT	25	12	78

• Most popular model. Air Inlet – 1/4" NPTF Recommended Air Pressure – 90 PSI (6.2 bar) Recommended Hose Size – 5/16" (8 mm) I.D.

## Ordering Information

Specify the Base Model Number having the desired speed from the specification chart above. Add the appropriate Dash Letter to indicate the desired spindle option from the chart below.

EXAMPLE: DR023B-21-D

## Spindle Options

Dash Letter	Spindle Option	Series 20 Models Free Speed					Series 50 Models Free Speed		
		500	1100	2100	3700	7300	2700	4100	5200
C	3/16" (4.8 mm) Collet <sup>1</sup>	•	•	•	•	•	•	•	•
D	10-32 Female Thd	•	•	•	•	•	•	•	•
E <sup>2</sup>	5/16" – 24 Female Thd	•	•	•	•	•	•	•	•
T	1/4"-28 Female Thd	•	•	•	•	•	•	•	•

• Indicates the model speeds on which a particular spindle option is available.

(1) Collet has a 9/32 – 40 male thread. Other size collets may be substituted for standard. See Collet 43497-(-) below.

(2) Not available DAO Series 20 and 50

## Series 43497-(-) One Piece Collets

Size No.	Dash No.	Size No.	Dash No.	Size No.	Dash No.	Size No.	Dash No.	Size No.	Dash No.	Size No.	Dash No.	Size No.	Dash No.	Size No.	Dash No.	Size No.	Dash No.
7	5.1 -7	14	4.6 -14	21	4.0 -21	28	3.5 -28	35	2.7 -35	42	2.3 -42	49	1.85 -49	56	1.18 -56	3/32	2.4 -163
8	5.0 -8	15	4.5 -15	22	3.9 -22	29	3.4 -29	36	2.7 -36	43	2.2 -43	50	1.77 -50	57	1.09 -57	7/64	2.77 -164
9	4.9 -9	16	4.4 -16	23	3.9 -23	30	3.2 -30	37	2.6 -37	44	2.1 -44	51	1.7 -51	58	1.06 -58	1/8	3.1 -165
10	4.9 -10	17	4.3 -17	24	3.8 -24	31	3.0 -31	38	2.5 -38	45	2.0 -45	52	1.6 -52	59	1.0 -59	9/64	3.6 -166
11	4.8 -11	18	4.3 -18	25	3.7 -25	32	2.9 -32	39	2.5 -39	46	2.0 -46	53	1.5 -53	60	1.0 -60	5/32	3.9 -167
12	4.8 -12	19	4.3 -19	26	3.7 -26	33	2.8 -33	40	2.4 -40	47	1.99 -47	54	1.39 -54	1/16	1.58 -161	11/64	4.3 -168
13	4.7 -13	20	4.0 -20	27	3.6 -27	34	2.8 -34	41	2.4 -41	48	1.9 -48	55	1.9 -55	5/64	1.98 -162	3/16	4.76 -169

# Drills and Tappers

**Torque Output: 1.0 to 54.5 ft-lbs (1.3 to 74.0 Nm)**

### Standard Equipment

- Chuck
- Suspension Bail on 78XX-E Models
- Side Handle on 600 and 325 rpm, 78XX-E Models

### Pistol Grip and Inline Drills

325 to 18,000 rpm / 0.7 hp (0.5 kW)

Capacity: 1/2" (12 mm) Chuck

- Excellent for production-line drilling of large diameter holes in farm implement and heavy equipment.
- Choice of pistol grip and lever styles.

### Right-Angle Drills

400 to 2,000 rpm / 0.85 hp (0.6 kW)

Capacity: 1/2" (12 mm) Chuck

Head Height w/Chuck: 4.6" (117 mm)

- Designed for drilling holes in limited access areas in sheet metal and woodworking applications.



7846-E



7852-E



7831-B

### Production Drills

Model No.	Speed rpm	Standard Chuck Cap.		Stall Torque		Spindle Thread Male	Spindle Offset		Tool Length		Tool Weight		@ Free Speed		Standard Chuck Part No.	
		in.	mm	ft-lbs	Nm		in.	mm	in.	mm	lbs	kg	Air Cons. cfm	Sound Level L/s dB(A)		
<b>Pistol</b>																
7845-E	4,500	3/8	9	4.0	5.4	1/2" - 20	1.0	25	8.3	210	3.9	1.8	31	14	88	33907
• 7846-E	2,400	3/8	9	7.5	10.0	1/2" - 20	1.0	25	8.3	210	3.9	1.8	31	14	88	33907
7847-E	1,100	1/2	9	16.0	22.0	1/2" - 20	1.0	25	10.5	267	5.4	2.4	31	14	88	30018
• 7848-E	600	1/2	12	29.5	40.0	1/2" - 20	1.0	25	10.5	267	5.4	2.4	31	14	88	30018
• 7849-E	350	1/2	12	54.5	74.0	1/2" - 20	1.0	25	10.5	267	5.4	2.4	31	14	88	30018
<b>Lever</b>																
7850-E	18,000	3/8	9	1.0	1.3	1/2" - 20	.9	24	9.6	244	3.2	1.5	31	14	88	33907
7851-E	4,500	3/8	9	4.0	5.4	1/2" - 20	.9	24	9.6	244	3.2	1.5	31	14	88	33907
7852-E	2,400	3/8	9	7.5	10.0	1/2" - 20	.9	24	9.6	244	3.2	1.5	31	14	88	33907
7853-E	1,100	3/8	9	16.0	22.0	1/2" - 20	.9	24	11.8	299	4.7	2.1	31	14	88	30016
7854-E	600	3/8	9	29.5	40.0	1/2" - 20	.9	24	11.8	299	4.7	2.1	31	14	88	30016
7855-E	325	3/8	9	54.5	74.0	1/2" - 20	.9	24	11.8	299	4.7	2.1	31	14	88	30016
<b>Right Angle</b>																
7832-B	2,000	3/8	9	10.0	13.0	3/8" - 24	.9	24	14.3	363	6.0	2.7	31	14	82	47341
• 7831-B	900	3/8	9	20.0	27.0	1/2" - 20	.9	24	16.0	406	7.5	3.4	31	14	82	30016
7830-B	400	1/2	12	44.0	60.0	1/2" - 20	.9	24	16.0	406	7.5	3.4	31	14	82	30018

• Most popular model. Air Inlet – 1/4" NPTF Recommended Air Pressure – 90 PSI (6.2 bar) Recommended Hose Size – 5/16" (8 mm) I.D.

### No Cost Options (Order "With" Option)

For Models	Part No.	Description	Substitute for Standard
All 78XX-E	33906	1/4" Chuck	Chuck
All 78XX-E	33907	5/16" Chuck	Chuck
All 78XX-E	30016	3/8" Chuck	Chuck
All 78XX-E	30018	1/2" Chuck	Chuck

# Flat-Angle Drills

## Drills and Tappers

**Torque Output: 4.0 to 8.3 ft-lbs (5.4 to 11.3 Nm)**

### Standard Equipment

- Suspension Bail
- 33500-3 Drive Spindle
- Choice of 33628-(-) Collet

### Flat-Angle Drills

**1,450 to 3,300 rpm / 0.4 hp (.3 kW)**

**Capacity: 1/4" (6 mm)**

- Excellent for drilling smaller diameter holes for airframe builders and metal fab shops.
- Flat angle allows reach into limited access areas.



7439-D

### Flat-Angle Drills

Model No.	Speed rpm	Standard Collet Cap.	Throttle Style	Stall Torque		Std. Spindle Thread Female	Tool Length		Angle Head Height w/o Collet		Tool Weight		@ Free Speed		Standard Spindle Part No.	
				ft-lbs	Nm		in.	mm	in.	mm	lbs	kg	Air Cons. cfm	L/s		Sound Level dB(A)
7441-D	3,300	Specify	Lever	4.0	5.4	1/4"-28	10.6	269	.7	17	2.9	1.3	24	11	86	33500-3
7439-D	2,500	Specify	Lever	3.0	4.1	1/4"-28	10.6	269	.7	17	2.9	1.3	24	11	86	33500-3
7438-D	1,450	Specify	Lever	8.3	11.3	1/4"-28	11.9	302	.7	17	3.5	1.6	24	11	86	33500-3

- Most popular model. Air Inlet – 1/4" NPTF Recommended Air Pressure – 90 PSI (6.2 bar) Recommended Hose Size – 5/16" (8 mm) I.D.

### No Cost Options (Order "With" Option)

Drive Spindle No.	Female Thread Size	For Use With
33500-5	1/4"-24	Threaded Bits
43494	9/32"-40	43497-(-) Collet <sup>1</sup>

(1) Choice of 43497-(-) Collet when flat angle is ordered with 43494 Spindle.

### Drive Spindles

The drive spindle of every flat-angle drill is an internal threaded gear. Three drive spindles are available so that various attachments can be used. The drive spindle is easily inserted into the angle head by removing the bottom plate.

### Chuck Adapter 33662<sup>2</sup>

**Use with 33500-3 Drive Spindle. Has 1/4"-28 male thread and #0 taper for use with:**

- Drill Chuck 30442, 5/32" Cap. (4 mm).
- Drill Chuck is at extra cost.

(2) May be substituted for choice of collet when ordered with 33500-3 Drive Spindle.



33662



33628



43497

### Series 33628-(-) One Piece Collets, Non-Precision

Use with 33500-3 Drive Spindle. Collet has 1/4"-28 male thread. Overall length (less thread) 23/32" (18.2 mm).

Drill Size	Dash No.	Drill Size	Dash No.	Drill Size	Dash No.	Drill Size	Dash No.	Drill Size	Dash No.	Drill Size	Dash No.	Drill Size	Dash No.	Drill Size	Dash No.	Drill Size	Dash No.
7	-1	15	-9	22	-16	30	-24	38	-32	46	-40	54	-48	5/64	-56	11/64	-64
8	-2	16	-10	23	-17	31	-25	39	-33	47	-41	55	-49	3/32	-57	7/32	-65
9	-3	17	-11	24	-18	32	-26	40	-34	48	-42	56	-50	7/64	-58	15/64	-66
10	-4	18	-12	25	-19	33	-27	41	-35	49	-43	57	-51	1/8	-59	1/4	-67
11	-5	19	-13	26	-20	34	-28	42	-36	50	-44	58	-52	9/64	-60	F	-68
12	-6	20	-14	27	-21	35	-29	43	-37	51	-45	59	-53	5/32	-61		
13	-7	20	-14	28	-22	36	-30	44	-38	52	-46	60	-54	11/64	-62		
14	-8	21	-15	29	-23	37	-31	45	-39	53	-47	1/16	-55	3/16	-63		

### Series 43497-(-) One Piece Collets, Non-Precision

Use with 43494 Drive Spindle. Collet has 9/32" - 40 male thread. Overall length – 1/2" (13 mm).

Drill Size	Dash No.	Drill Size	Dash No.	Drill Size	Dash No.	Drill Size	Dash No.	Drill Size	Dash No.	Drill Size	Dash No.	Drill Size	Dash No.	Drill Size	Dash No.	Drill Size	Dash No.
7	-7	14	-14	21	-21	28	-28	35	-35	42	-42	49	-49	56	-56	3/32	-163
8	-8	15	-15	22	-22	29	-29	36	-36	43	-43	50	-50	57	-57	7/64	-164
9	-9	16	-16	23	-23	30	-30	37	-37	44	-44	51	-51	58	-58	1/8	-165
10	-10	17	-17	24	-24	31	-31	38	-38	45	-45	52	-52	59	-59	9/64	-166
11	-11	18	-18	25	-25	32	-32	39	-39	46	-46	53	-53	60	-60	5/32	-167
12	-12	19	-19	26	-26	33	-33	40	-40	47	-47	54	-54	1/16	-161	11/64	-168
13	-13	20	-20	27	-27	34	-34	41	-41	48	-48	55	-55	5/64	-162	3/16	-169

# Drills and Push-Pull Tapper

## Drills and Tappers

**Torque Output: 2.5 to 23.0 ft-lbs (3.4 to 31.2 Nm)**

### Standard Equipment

- Chuck

### Pistol Grip Drills

575 to 5,300 rpm / .7 hp (.5 kW)

950 to 3,800 rpm / .5 hp (.4 kW)

Capacity: 1/4" (6 mm) and 3/8" (9.5 mm)

- Model DG055A(-) and 8426(-) drills are excellent general purpose tools.



DG055A-21-B



8426-5

### Pistol Drills

Model No.	Speed rpm	Standard Chuck Cap.		Stall Torque		Spindle Thread Male	Spindle Offset		Tool Length		Tool Weight		@ Free Speed		Standard Chuck Part No.	
		in.	mm	ft-lbs	Nm		in.	mm	in.	mm	lbs	kg	Air Cons. cfm	Sound Level L/s dB(A)		
<b>Pistol</b>																
DG055A-38-F	3,800	5/16	8	2.5	3.4	3/8"-24	0.9	23	7.0	177	2.4	1.1	19	9.0	83	-
DG055A-21-B	2,100	3/8	10	4.5	6.1	3/8"-24	0.9	23	7.3	184	2.5	1.1	19	9.0	83	-
DG055A-10-L	950	1/2	13	10.0	13.6	3/8"-24	0.9	23	8.3	212	3.1	1.4	19	9.0	83	-
8426-2	5,300	3/8	9	3.7	5.0	3/8"-24	1.1	27	7.3	85	3.3	1.5	33	15.6	86	47341
8426-3	3,250	3/8	9	6.0	8.1	3/8"-24	1.1	27	7.3	185	3.3	1.5	33	15.6	86	47341
8426-4	2,600	3/8	9	7.4	10.0	3/8"-24	1.1	27	7.3	185	3.3	1.5	33	15.6	86	47341
8426-5	1,550	3/8	9	11.5	15.6	3/8"-24	1.1	27	9.0	229	3.8	1.7	33	15.6	86	30896
8426-6	950	3/8	9	19.5	26.4	3/8"-24	1.1	27	9.0	229	3.8	1.7	33	15.6	86	30896
8426-7	575	3/8	9	23.0	31.2	3/8"-24	1.1	27	9.0	229	3.8	1.7	33	15.6	86	30896
8525-C	2500	1/4	6	3.6	4.9	3/8"-24	0.9	22	6.0	153	2.7	1.2	26	12.3	84	41084
8526-C	4500	1/4	6	3.6	4.9	3/8"-24	0.9	22	6.0	153	2.7	1.2	26	12.3	84	41084

Air Inlet – 1/4" NPTF Recommended Air Pressure – 90 PSI (6.2 bar) Recommended Hose Size – 5/16" (8 mm) I.D.



8506-ADB



8506-ATA

### Quick Reverse Tappers (QRT)

Model No.	Speed rpm	Standard Chuck Capacity	Stall Torque		Spindle Thread Male	Spindle Offset		Tool Length		Tool Weight		@ Free Speed		Standard Chuck Part No.	
			in.-lbs	Nm		in.	mm	in.	mm	lbs	kg	Air Cons. cfm	Sound Level L/s dB(A)		
<b>Pistol</b>															
8506-ATA	600	NO. 0 - 1/4"	110	12.5	3/8"-24	0.9	23	8.2	208	2.7	1.2	24	11.3	82	31427
8506-ATB	600	NO. 10 - 5/16"	110	12.5	3/8"-24	0.9	23	8.2	208	2.7	1.2	24	11.3	82	31432
8506-ATC	600	5/16" - 5/8"	110	12.5	3/8"-24	0.9	23	8.2	208	2.7	1.2	24	11.3	82	32060
8509-ATA	900	NO. 0 - 1/4"	80	9.1	3/8"-24	0.9	23	8.2	208	2.7	1.2	26	12.2	82	31427
8509-ATB	900	NO. 10 - 5/16"	80	9.1	3/8"-24	0.9	23	8.2	208	2.7	1.2	26	12.2	82	31432
8509-ATC	900	5/16" - 5/8"	80	9.1	3/8"-24	0.9	23	8.2	208	2.7	1.2	26	12.2	82	32060
8506-ADB	600	3/8"	110	12.5	3/8"-24	0.9	23	8.0	203	2.9	1.3	24	11.3	82	47341
8506-ADK	600	1/2"	110	12.5	3/8"-24	0.9	23	8.0	203	2.9	1.3	24	11.3	82	34518
8509-ADB	900	3/8"	80	9.1	3/8"-24	0.9	23	8.0	203	2.9	1.3	26	12.2	82	47341
8509-ADK	900	1/2"	80	9.1	3/8"-24	0.9	23	8.0	203	2.9	1.3	26	12.2	82	34518

Air Inlet – 1/4" NPTF Recommended Air Pressure – 90 PSI (6.2 bar) Recommended Hose Size – 5/16" (8 mm) I.D.

# Drills and Tappers

## Standard Equipment

- Tapping Chuck
- Necessary Wrenches
- 48932 Dead Handle w/8426 - 6 & 7.

## Push-Pull Tapper

550 rpm / .45 hp (0.3 kW)

Capacity: 5/8" (15 mm) Tap Chuck

- Designed for thread-chasing applications in metal fab shops after painting and cleanup operations.

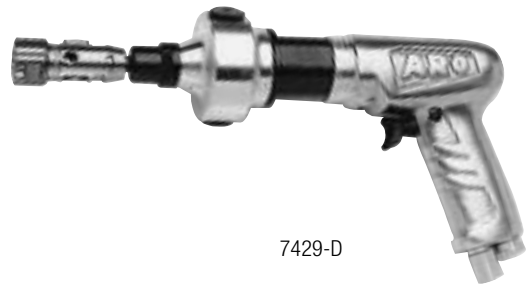

7429-D

## Push-Pull Tapper

Model No.	Free Speed rpm	Standard Chuck Cap. in. mm	Stall Torque ft-lbs Nm	Spindle Offset in. mm	Spindle Length in. mm	Tool Weight lbs kg	@ Free Speed Air Cons. cfm L/s	Sound Level dB(A)	Standard Chuck Part No.
<b>Pistol</b>									
7429-D	550	5/16 7	19 25.8	1.3 34	12 305	3.9 1.8	27 13	85	31432

• Most popular model. Air Inlet – 1/4" NPTF Recommended Air Pressure – 90 PSI (6.2 bar) Recommended Hose Size – 5/16" (8 mm) I.D.

## Extra Cost Accessories

For Models	Part No.	Description
7429-D	44360-( )	Piped Exhaust Assembly

## No Cost Options (Order "With" Option)

For Models	Part No.	Description	Substitute for Standard
7429-D	31427	Tapping Chuck	Chuck
7429-D	32060	Tapping Chuck	Chuck



## Keyed Drill Chucks

Capacity in. mm	Thread Female	Chuck No.	Key No.
5/32 4	No. 0 Taper	30442	30442-K
1/4 6	No. 1 Taper	36953	30209-K
1/4 6	3/8"-24	31330	31330-K
1/4 6	3/8"-24	41084	41084-K
1/4 6	3/8"-24	47340	30209-K
1/4 6	1/2"-20	33906	30209-K
3/8 9	3/8"-24	30896	30896-K
3/8 9	3/8"-24	47341	30510-K
3/8 9	1/2"-20	30016	30016-K
3/8 9	1/2"-20	33907	30510-K
1/2 13	3/8"-24	34518	30016-K
1/2 13	1/2"-20	30018	30016-K

Note: Key is included with Chuck.

## Drill Collets

Capacity in. mm	Collet 3/8"-24 Female	Chuck Insert No.
3/32 to 1/8 3	32984-1	32968-1
1/8 to 5/32 3	32984-2	32968-2
5/32 to 3/16 4	32984-3	32968-3
3/16 to 7/32 5	32984-4	32968-4
7/32 to 1/4 6	32984-5	32968-5
1/4 to 9/32 7	32984-6	32968-6
9/32 to 5/16 7	32984-7	32968-7
5/16 to 11/32 8	32984-8	32968-8
11/32 to 3/8 9	32984-9	32968-9

Note: Collet insert is included with Collet.

## Quick-Change Chucks

Hex Drive Cap. in.	Mounting Thread Female	Chuck No.
1/4"	3/8"-24	30712
7/16"	1/2"-20	31367

## Tapping Chucks

Capacity in. mm	Chuck No.
0 to 1/4 0 to 6	31427
No. 10 to 5/16 7	31432
5/16 to 5/8 7 to 15	32060 <sup>1</sup>

(1) Includes 32064 Adapter.

## Spindle Adapters

Drive Spindle	Mounting Thread Female	Adapter No.
1/2"-20 (male)	3/8"-24	30629
1/2"-20 (male)	1/2"-20	40847
3/8" sq.	3/8"-24	30384-5
1/2" sq.	3/8"-24	30384-9
1/2" sq.	1/2"-20	40768



# Impact Wrenches



## Impact Wrench Selection

To determine the ARO Impact Wrench that's best suited for your application, it is important to consider the following criteria:

- A Square Drive Size** – Generally, the square drive of the wrench should be the same size or larger than the thread diameter of the fastener. ARO Impact Wrenches are available in 3/8", 1/2", and 3/4" square drives.
- B Torque Requirements** – Match the job's torque requirements with the torque output of the wrench. The recommended torque ranges for each ARO Impact Wrench and the torque requirements to tighten or loosen 3/8" to 3/4" bolts are shown in the selection guide. Notice that it takes more torque to loosen a bolt than it does to tighten it, particularly if the bolt is rusted or galled. For longer, more reliable performance, the torque requirements should be within the recommended range of the tool — not the tool's maximum torque.
- C Job Demands** – To ensure maximum service life, the Production Class or durability of the wrench should meet the demands of the intended applications. Demanding jobs, operating near the upper limit of a tool's recommended production torque, or frequent assembly cycles over extended periods, require an "Industrial" class wrench. For intermittent assembly, maintenance, and utility jobs, the "Economy" class wrench is ideal.

Square Drive	Impact Wrench Model	Rec. Production Torque		Bolt Size (Thread Diameter)						
		ft-lb	Nm	3/8" (9.5 mm)		1/2" (12.7 mm)		3/4" (19 mm)		
				T	L	T	L	T	L	L
3/8"	WG037A-B1	20-100	27-136							
3/8"	WL037A-B1	20-100	27-136							
1/2"	WG047A-D1	40-350	54-474							
3/4"	WG068A-F4	200-600	271-813							

  

Torque	ft-lb	0	100	200	300	400	500	600
	Nm	0	136	271	407	542	678	813

Recommended torque range of tool.  
 Torque range required to tighten (T) or loosen (L) bolt size.

## Model Identification Guide

Example: WG037A-B1

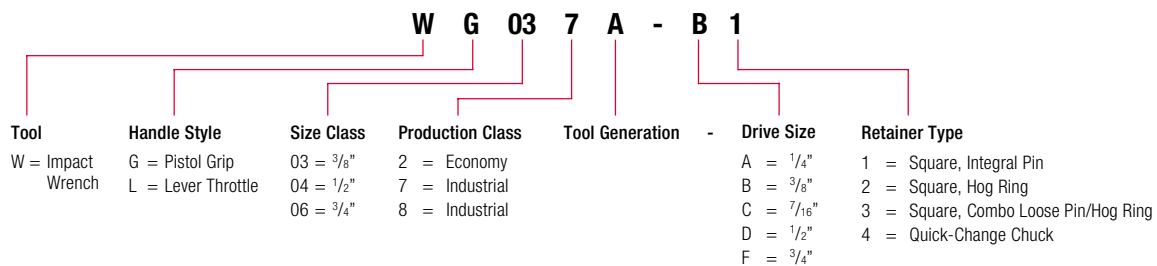

3/8" Drive

# Impact Wrenches

## Torque Output: 125 ft-lb (169 Nm)

ARO is proud to offer a line of premium-quality, high-performance air impact wrenches. Durable, powerful, and easy-to-handle, they're ideal for use in a wide range of assembly, maintenance, and service operations.

### Features include:

- The built-in Power Regulator lets you switch from lower power in one direction to full power in the opposite direction for extra performance when you need it most.
- A unique Pressure-Feed Lubrication System automatically distributes injected grease to the hammer mechanism to add longer, trouble-free service life.
- A rugged hammer design with fewer moving parts simplifies maintenance, reducing tool downtime and repair costs.
- Rotary hammering action delivers balanced blows for greater consistency and handling comfort.
- Reversible operation provides maximum utility.
- Models available in the most popular driver sizes with torque output of up to 1000 lb.ft. (1360 Nm).



WL037A-B1

## Industrial and Economy 3/8" Impact Wrenches

### Features

- Built-in pressure-feed lubrication system
- Built-in power regulator
- Smooth, efficient impact mechanism
- Rugged steel hammer case
- Integral muffler

### Accessories at Extra Cost

- 48951-37 Vertical Hanger
- 48951-38 Horizontal Hanger
- Tune-up Kit for Model WG037A-( )
- Tune-up Kit for Model WL037A-( )
- 212-K23 Muffler Kit



WG037A-B1

## 3/8" Impact Wrenches

Model Number	Drive Type	Free Speed rpm	Impacts per Minute	Max. Torque		Rec. Torque Range		Standard Bolt Cap.		Spindle Offset		Length		Weight	
				ft-lb	Nm	ft-lb	Nm	in.	mm	in.	mm	in.	mm	lbs	kg
<b>Straight</b>															
WL037A-B1	3/8" Square	7,000	1,500	125	169	20-100	27-136	7/16	11	1.375	35	5.875	149	2.5	1.1
WL037A-A5	1/4" Hex Quick-Change	7,000	1,500	125	169	20-100	27-136	7/16	11	1.375	35	5.875	149	2.5	1.1
WL037A-C5	7/16" Hex Quick-Change	7,000	1,500	125	169	20-100	27-136	7/16	11	1.375	35	5.875	149	2.5	1.1
<b>Pistol Grip</b>															
WG037A-B1	3/8" Square	10,000	1,500	125	169	20-100	27-136	7/16	11	1.375	35	5.5	140	2.75	1.2
WG037A-A5	1/4" Hex Quick-Change	10,000	1,500	125	169	20-100	27-136	7/16	11	1.375	35	5.5	140	2.75	1.2
WG037A-C5	7/16" Hex Quick-Change	10,000	1,500	125	169	20-100	27-136	7/16	11	1.375	35	5.5	140	2.75	1.2

Air Inlet – 1/4" NPTF (Female) Recommended Air Pressure – 90 PSI (6.2 bar) Recommended Hose Size – 5/16" (8 mm) I.D.

# 1/2" and 3/4" Drive Impact Wrenches

## Torque Output: 500 ft-lb (678 Nm)

### Industrial 1/2" Impact Wrenches

Model WG047A-D1 is a powerful industrial-grade tool for the most demanding fastening applications.

#### Features

- Built-in pressure-feed lubrication system
- Built-in power regulator
- Rugged steel hammer case (Model WG047A-D1)
- Integral muffler

#### Optional Equipment

Model WG047A-D1:

- 48951-161 Anvil Assembly with 7/16" Hex Quick-Change Chuck
- 48951-173 Anvil Assembly with 1/2" Square Ring Retainer

#### Accessories at Extra Cost

- 48951-94 Horizontal Hanger for Model WG047A-D1
- 48965 Service Kit for Model WG047A-D1



WG047A-D1

### 1/2" Impact Wrenches

Model Number	Drive Type	Free Speed rpm	Impacts per Minute	Max. Torque		Rec. Torque Range		Standard Bolt Cap.		Spindle Offset		Length		Weight	
				ft-lb	Nm	ft-lb	Nm	in.	mm	in.	mm	in.	mm	lbs	kg
<b>Industrial</b>															
WG047A-D1	1/2" Square	7,000	1,300	500	678	40-350	54-474	5/8	15.9	1.375	35	6.5	165	6.0	2.7

Air Inlet – 1/4" NPTF (Female) Recommended Air Pressure – 90 PSI (6.2 bar) Recommended Hose Size – 5/16" (8 mm) I.D.

# 3/4" Drive Impact Wrenches

## Torque Output: 1000 ft-lb (1360 Nm)

### Industrial 3/4" Impact Wrenches

#### Features

- Built-in pressure-feed lubrication system
- Smooth, efficient impact mechanism
- Steel hammer case
- Integral muffler

#### Accessories at Extra Cost

- 49852 Service Kit



WG068A-F4

### 1/2" Impact Wrenches

Model Number	Drive Type	Free Speed rpm	Impacts per Minute	Max. Torque		Rec. Torque Range		Standard Bolt Cap.		Spindle Offset		Length		Weight	
				ft-lb	Nm	ft-lb	Nm	in.	mm	in.	mm	in.	mm	lbs	kg
<b>Industrial</b>															
WG068A-F4	3/4" Square	5,500	1,000	1,000	1,360	200-600	271-813	3/4	19	2.28	48	7.625	194	11.625	5.39

Air Inlet – 3/8" NPTF (Female) Recommended Air Pressure – 90 PSI (6.2 bar) Recommended Hose Size – 1/2" (13 mm) I.D.

## Ergonomic Accessories

# Workstations

---

**Defining the state-of-the-art in workstation designs, ARO workstations are an integral part of the continuous effort to improve operator comfort, safety, and productivity. The stable environment of a workstation absorbs any reaction torque from a fastening tool and eliminates excessive gripping force.**

Tools positioned closer to the workpiece are more accessible to the operator, reducing both the physical movement and time it takes to perform a function. By reducing the amount of effort required for a task, operator's energy levels remain high. A Balancer, or arm suspension, literally takes the weight of the tool out of the operator's hand.

Workstations promote better organization of the assembly area and reduce unnecessary clutter. The more aesthetically pleasing work environment encourages good housekeeping habits and builds pride in workmanship. In addition, suspending valuable tools off the bench top helps prevent damage from being dropped or mishandled. The available ARO Module/Air 2000 Lubricator and Filter/Regulator also extends the life of your air tool by providing clean, dry, lubricated air close to the job site.

---

### Parallel Arm Workstations

Parallel Arm Workstations represent the best in tool support ARO has to offer. Engineered for both ergonomic and production

benefits, they offer unsurpassed operator comfort and safety, with increased productivity and quality consistency. With the loss of main inlet air to the arm check valve prevents it from dropping suddenly to the valve surface causing possible injury or work spoilage. Unlike the clumsy and limited spring-operation of other tool support devices, the ARO Workstations feature a unique double-swivel, parallel arm design with an adjustable air bias.

The Parallel Arm Workstations with rigid tool mounting help absorb reaction torque transmitted to the operator. With the proper fastening tool and set-up, operator variables in assembly quality can be virtually eliminated, maintaining consistent quality standards.

The handsome lines and superior finish make these workstations an attractive addition to even the most modern assembly environment. Both bench and wall mount styles — with 30" arm reach — are available to meet your installation requirements.

- Built-in ARO Miniature Air Regulator allows fine adjustment of the arm tension to ideally match the weight of the tool. Positioning the tool becomes virtually effortless.
- E-Coat and Anodized finishes provide exceptional corrosion resistance while maintaining the unit's "showroom-like" appearance.
- ARO Filter/Regulator-Lubricators provide clean, dry, and lubricated air close to the job site for optimal performance and extended service life.
- Heavy-duty Steel Tubing and Aluminum Construction are designed for long, trouble-free service in high-volume conditions.
- Rigid Tool Mounting with air bias prevents damage to valuable tools caused by dropping and mishandling while ensuring proper fastener alignment to minimize rework.

### Single Arm Workstations

ARO Single Arm Workstations are the new standard of value for tool hanging devices. The unique construction of the ARO workstations allow you to custom design a unit to meet your exact production requirements. The torque reaction arm provides increased operator safety and comfort, while enabling greater tool maneuverability than competitive torque arms.

The handsome, superior look makes these workstations an attractive addition to any assembly environment. Both bench and wall mount styles — with 24" or 30" swing arms — are available to meet your installation requirements.

- Telescoping Torque Reaction Arm helps reduce torque reaction transmitted to the operator in highly repetitive operations.
- A choice of three ARO Adjustable Spring Balancers help maintain operator productivity and protect valuable power tools.
- Roller-mounted Balancer Hanger enables smooth, effortless travel along the length of the swing arm.
- 1<sup>1</sup>/<sub>4</sub>" Steel Tubing Construction with tough Composite Bushing Material provides unmatched durability to withstand the demands of high volume production.
- 42" Post Height positions the swing arm above and away from the operator's head for safety and an unobstructed view of the work area.
- Heavy-duty Steel Tubing and Aluminum Construction are designed for long, trouble-free service in high-volume conditions.
- Rigid Tool Mounting with air bias prevents damage to valuable tools caused by dropping and mishandling while ensuring proper fastener alignment to minimize rework.

# Dimensions Workstations

## Parallel Arm Style

Model WB230B-(-)

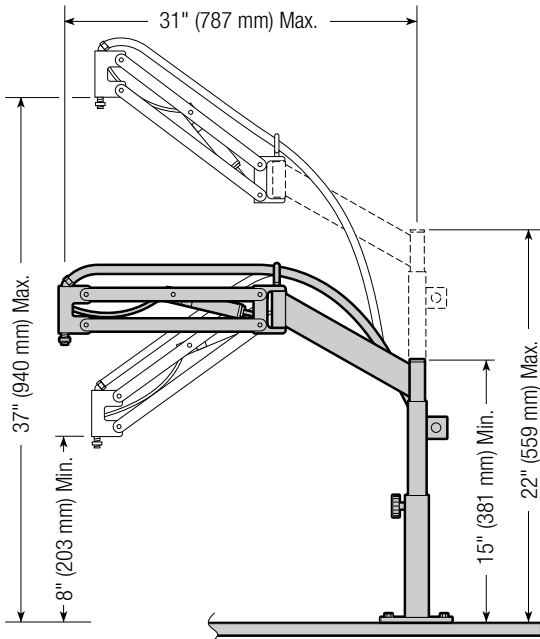

Bench Mount Models

## Single Arm Style

Model WB124A-(-)

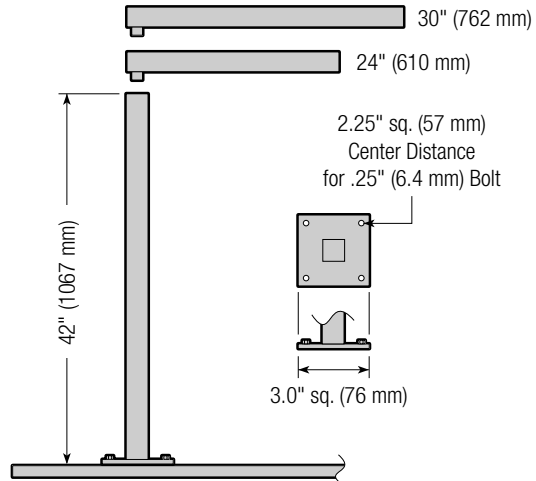

Model WW230B-(-)

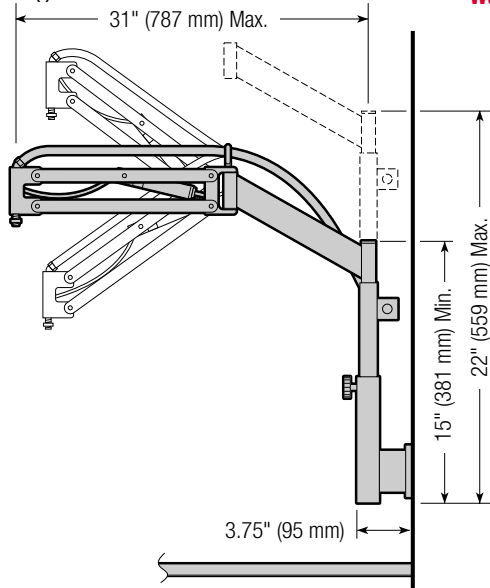

Wall Mount Models

Model WW124A-(-)

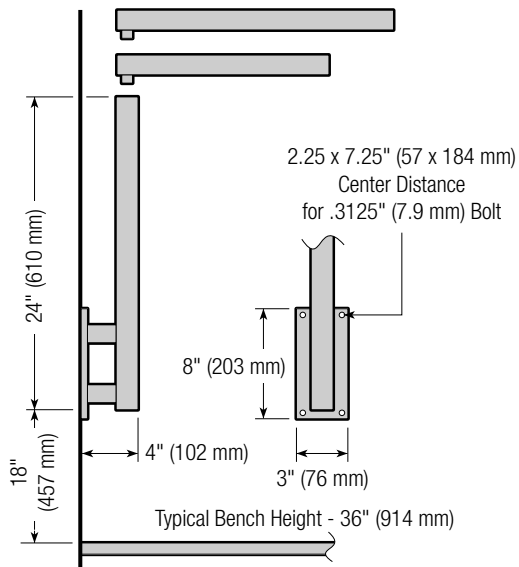

## Working Area

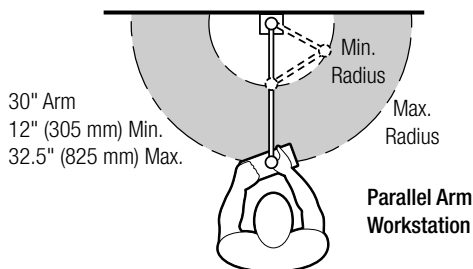

Parallel Arm  
Workstation

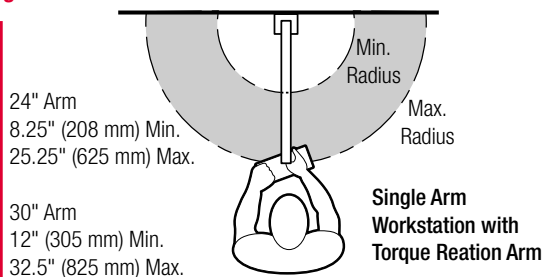

Single Arm  
Workstation with  
Torque Reaction Arm



# Parallel Arm Workstations

## Model Identification Guide

Example: WB124A-324

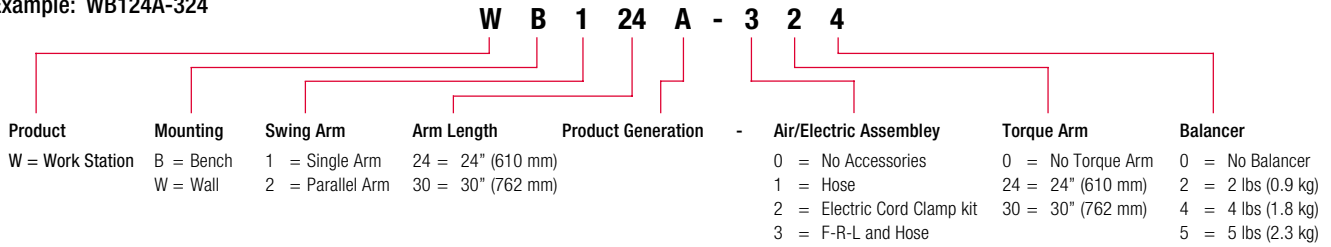

Model-P29221-110  
ARO Module/Air 2000  
Series Filter / Regulator  
1/4" Port Size  
0-160 PSI Gauge

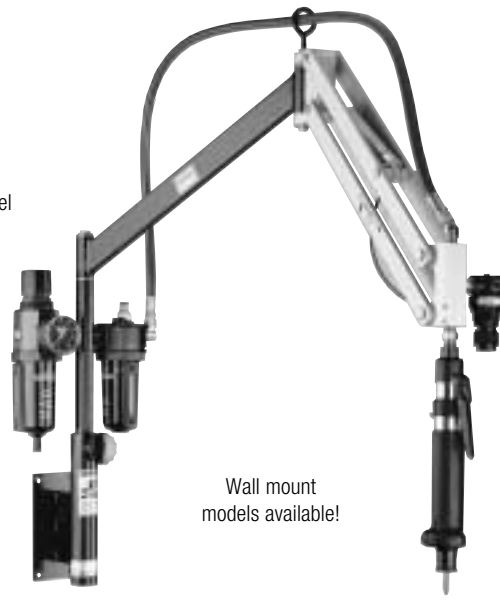
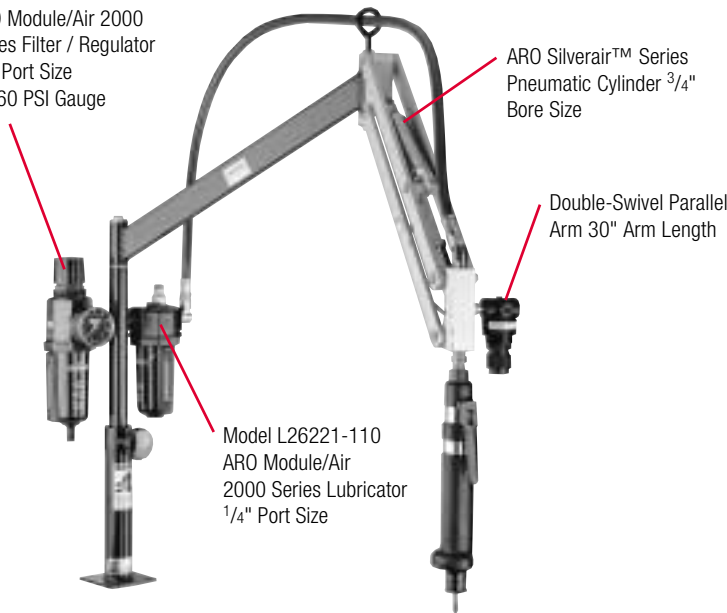

**Bench Clamp Accessory**  
(Available at extra cost)  
• 48732-1

**Tool Holding Bracket Accessory**  
(Available at extra cost)  
• 49380-1 for use with electric screwdrivers or other 2.0" diameter electric tools

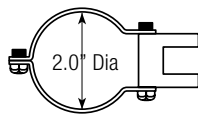

**Wall mount models available!**

**Balancers:**  
• 8375-2 (2 lbs cap.)  
• 8375-4 (4 lbs cap.)  
• 7472 (5 lbs cap.)  
**Torque Arm Assemblies**  
(to match boom length)  
• 48723-2 (24")  
• 48723-3 (30")



## Ordering Information

- Specify the Base Model No. for the mounting style desired (bench or wall mount). Example: WB230B-.
- Add the Accessory Dash No. representing the desired accessory options. Example: WB230B-300.

### 30" (762 mm) Swing/Parallel Arm

Base Model		Accessories Dash Number	Accessories Options			Maximum		Weight lbs	kg
Bench Mount	Wall Mount		F-R-L A	Hose and Tubing	Mini Regulator	Torque in.-lbs	Nm		
30" (762 mm)									
WB230B-(-)	WW230B-(-)	300	•	•	•	144	16.3	18	8.2
WB230B-(-)	WW230B-(-)	100	-	•	•	144	16.3	18	8.2

Note:  
All models are equipped with an ARO Miniature Series Regulator.  
Parallel Arm Only: Max. Weight 18 lbs., Max. Torque 144 in.-lbs.

### SE Electric Tool Clamp

(Versatec)  
• 49091

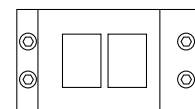
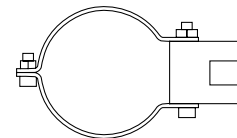

# Single Arm Workstations

## Ordering Information

1. Determine the arm length requirement (24" or 30").
2. Specify the Base Model No. for the mounting style desired (bench or wall mount).

**Example: WB124A-**

3. Add the Accessory Dash No. representing the desired accessory options.

**Example: WB124A-324.**

Model P29221-110  
ARO Module Air/2000 Series Filter / Regulator  
1/4" Port Size 0-160 PSI Gauge

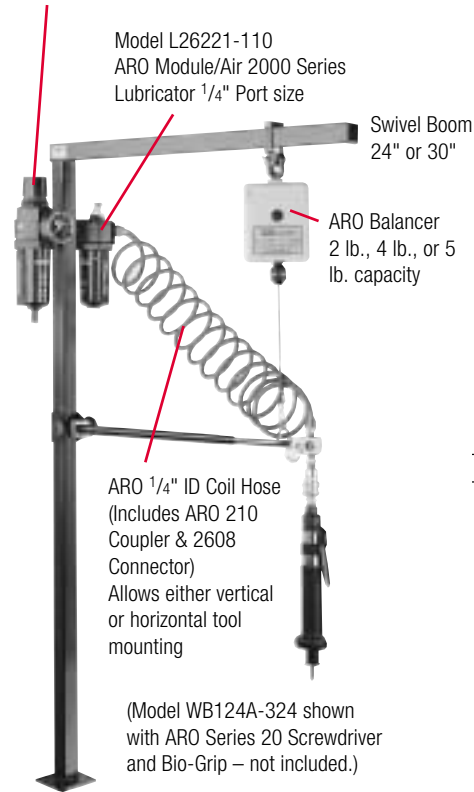

## Swing/Single Arm

Base Model		Accessories Dash Number	Accessories Options			Maximum				
Bench Mount	Wall Mount		F-R-L A	Hose B	Clamp Kit C	Torque Arm D	Balancer E			
						2 lb	4 lb	5 lb		
<b>24" (610 mm)</b>										
WB124A(-)	WW124A(-)	300	•	•						
		302	•	•			•			
		304	•	•					•	
		305	•	•					•	
		322	•	•		•	•			
		324	•	•		•			•	
		325	•	•		•				
		200 <sup>2</sup>				•				
		202				•		•		
		204				•			•	
		205				•				•
		222 <sup>1</sup>				•	•	•		
		224 <sup>1</sup>				•	•		•	
		102				•		•		
		104				•				•
		105				•				•
		122				•		•	•	
		124				•		•		•
		125				•		•		•
		000								
		002						•		
		004								•
005								•		
022					•	•				
024					•		•			
025					•			•		
<b>30" (762 mm)</b>										
WB130A(-)	WW130A(-)	300	•	•						
		302	•	•			•			
		304	•	•					•	
		305	•	•					•	
		332	•	•		•	•			
		334	•	•		•			•	
		335	•	•		•			•	
		200				•				
		202 <sup>2</sup>				•		•		
		204				•			•	
		205				•				•
		232 <sup>1</sup>				•	•	•		
		234 <sup>1</sup>				•	•		•	
		102				•		•		
		104				•				•
		105				•				•
		132				•		•	•	
		134				•		•		•
		135				•		•		•
		000								
		002						•		
		004								•
005								•		
032					•	•				
034					•		•			
035					•			•		

Note: All models are equipped with a Roller Bail Assembly to hang a balancer, regardless of whether or not a balancer is ordered with the workstation.

(1) Equipped with tool holder bracket for 2.0" Dia. electric tools.

(2) For electric tools.

## Finishing Tools



ARO covers the full spectrum of surface preparation tasks with its extensive line of finishing tools. For heavy material removal in metalworking, the new Elite Series heavy duty grinders combine superior performance with exclusive operator convenience and safety features. Similar heavy duty sanders and polishers are also available. For lighter material removal and smaller workpieces, standard Elite Series die grinders, sanders, and polishers incorporate unmatched operator ergonomics, as well as plenty of power and versatility for all types of materials. The Classic Line tools complete the offerings, also in a variety of sizes and configurations.

As the originator of random orbital sander technology, ARO has long been synonymous with high performance finishing. And now, with the introduction of the new Elite Series models, ARO redefines the standards. Through the use of advanced materials and years of expertise, ARO has achieved outstanding speed under load, while improving operator comfort and control. The Elite random orbital sanders are fast becoming the new tool of choice in furniture, molded components and automotive production. In addition, ARO offers its well-established Classic Line random orbital sanders, in non-vacuum, vacuum-ready, and venturi-vacuum variations — all with further improved performance and durability.

Throughout the ARO finishing tools line, you'll find examples of performance benefits from proven innovations...such as lightweight composite housings, handle and grip designs that minimize operator fatigue, reduced noise and vibration, and simplified modular construction. ARO is leading the industry in the further development of lube-free operation and vacuum sanding for a cleaner work environment. And the latest Elite Models conform to the varied requirements of different size operators, male and female.

Whether you're cleaning and blending welds...or preparing the intricate surfaces of fine furniture, ARO delivers high performance finishing.

 **ELITE**<sup>®</sup>

**Jet Vac Random Orbital Sanders** ..... Pgs. 59 – 60

The Jet-Vac™ System delivers twice the vacuum power of the nearest competitor and uses an exclusive disposable dust bag enclosed in a protective cover.

**Random Orbital / Orbital Sanders** ..... Pgs. 61 – 65

Choose from a comprehensive selection of new Elite or Classic Line Models, in vacuum or non-vacuum configurations, from the originators of random orbital sanding.

**Grinders, Sanders, and Polishers** ..... Pgs. 66 – 83

Review the new Heavy Duty Elite Series models for heavy material removal, as well as the standard Elite models, with superior ergonomic design. The Classic Line models meet still more applications, and complete the selection.

**Finishing Tools** ..... Pgs. 84 – 85

ARO offers a full line of high performance accessories including replacement sanding pads, wheel guards, and adapter kits.

The new ARO Elite Series heavy duty grinders tackle heavy material removal tasks with ease.





## Elite, Jet Vac and Classic Line Random Orbital Sanders **Finishing Tools**



The originator of random orbital finishing has just raised the standards of performance. ARO has applied the latest in ergonomic design and advanced materials technology to refine its Classic Line of random orbital sanders...and to introduce a completely new range: the Elite Series.

The ARO line of random orbital finishing tools is now the most comprehensive in the industry, providing a choice of traditional aluminum housings...or the ultimate in lightweight, composite packaging and efficient performance. Both the Classic Line and Elite Series incorporate new moisture-

resistant composite rotors, fully machined counterweights, and larger counterweight bearings for superior reliability. Both continue the ARO advantage of operating with totally dry air power for a cleaner work environment. And both "mini" models deliver 50 percent more power than previous models, ensuring greater speed under load and the finest in swirl-free finishes.

Now you can choose from four configurations, based on design, size, and vacuum orientation.

### **ELITE Composite "Mini" Sanders**

Non-Vac and Vac-Ready.

### **Jet Vac Composite Sanders**

High efficiency integral vacuum, with hose and double bag.

### **Classic Line Aluminum "Mini" Sanders**

Non-Vac, Vac-Ready, and Venturi-Vac

### **Classic Line Aluminum Standard Size Sanders**

Non-Vac, Vac-Ready and Venturi-Vac

All ARO random orbital sanders are backed by an exclusive two-year warranty, twice the coverage offered on competitive products. And ARO teams these tools with a complete line of premium-quality sanding pads and accessories, for a total package of sanding solutions. Read on, and discover all of the details on the innovative new Elite Series, as well as the ARO Classic Line. Your ARO representative or distributor will help you achieve high-performance finishing for your application.



# Elite Random Orbital Sanders Finishing Tools

As the name suggests, the new ARO Elite Series represents the best in random orbital sander design and performance. More power, speed, and durability than ever before. Better vacuum efficiency. And a new standard of operator comfort. However, the most important things may just be what ARO has taken away. There's less weight and less noise than ever before. Your operators will feel the difference in the superb handling. Your customers will see the difference in their superb finishes. The Elite Series is the new definition of leadership from the people who originated random orbital sanding.



## Lightweight:

The one-piece precision-molded composite housing provides unmatched strength and durability...and helps reduce overall weight to 1.83 lbs. for less operator fatigue over extended periods, contributing to greater productivity.

## Quiet:

New materials and internal refinements have cut sound pressure to just 78 dBa, for a more pleasant work environment.

## Efficient:

ARO has developed new ways to extract maximum power from the air motor, achieving true 12,000 rpm performance.

## 100% Made In The USA:

All ARO Elite Series sanders are built by skilled technicians at our Southern Pines, North Carolina plant, using U.S.-sourced parts and components.

## Improved Vacuum Action

The Elite Series vacuum-ready models extract dust and particulates through and around the pad...and then directly up and out a dedicated port, keeping foreign matter away from the motor. The vacuum sanding pad features a unique "petal" design and large 1/2-inch diameter holes for greater efficiency. The clear, unobstructed path ensures that virtually all dust is instantly channeled away from the work. Special shroud material protects the work surface from marring, while enhancing vacuum characteristics. Elite Series vacuum-ready models connect easily to portable or central vacuum systems with new lighter, more flexible hoses that permit better maneuverability.

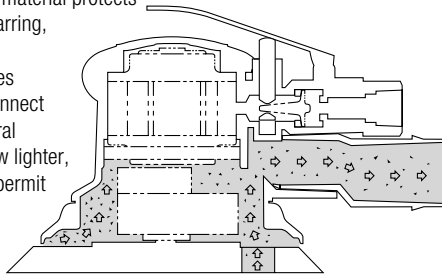

Another unique Elite Series feature: all non-vacuum models can be easily converted to vacuum-ready status with the simple addition of a vacuum adapter and vacuum sanding pad.

## Reduced Vibration

Inside the motor housing, ARO developed a fully machined counterweight that balances the power of the high-efficiency air motor and significantly reduces vibration. The counterweight bearing has been enlarged to provide twice the life. In addition, ongoing testing confirms that the ARO weight-matched sanding pad and counterbalance combination delivers unsurpassed smoothness.

On the outside, the Elite Series composite housing — with its ability to insulate and absorb energy — further reduces the effects of vibration transmitted to the operator.

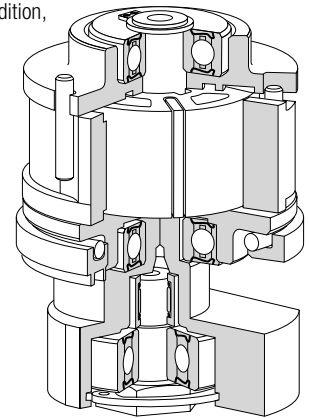

## Perfect Fit for all Hands

With the ARO Elite Series, one sander fits all. Three sizes of soft, color-keyed rubber grip rings fit securely around the top of the housing, and allow a custom match to operator hand size.

The grip rings are easily interchangeable, provide a comfortable, non-slip surface for control, and insulate further against vibration and cold. Grip rings are available as accessories according to individual customer needs.



# Elite and Jet Vac Random Orbital Sanders Finishing Tools

## Non-Vacuum and Vacuum Ready

ARO Elite Series sanders are available in five non-vacuum model variations, with 3.5-inch, or 6-inch pads, and duck or vinyl pad faces. The non-vac versions can subsequently be converted to vacuum status with the simple addition of an available vacuum adapter, a petal pad, and a change in shroud if desired.



For applications requiring dust-free operation, choose from five models of Elite Series vacuum-ready sanders, for use with central or portable vacuum systems. Select short shrouds for maximum workpiece visibility, or long shrouds for maximum dust evacuation. The improved ARO vacuum hose is now 65 percent lighter than previous versions, for better operator convenience.



## Jet Vac

ARO has created a unique new addition to the Elite Series of random orbital sanders— one that sets a new performance standard for self generated vacuum sanding. The new Jet Vac™ System delivers twice the vacuum power of the nearest competitor and uses an exclusive disposable dust bag enclosed in a protective cover. This “double bagging” system provides a cleaner work environment, and promotes the proper disposal of collected particulates for maximum total effect.



## Jet Vac System Detail

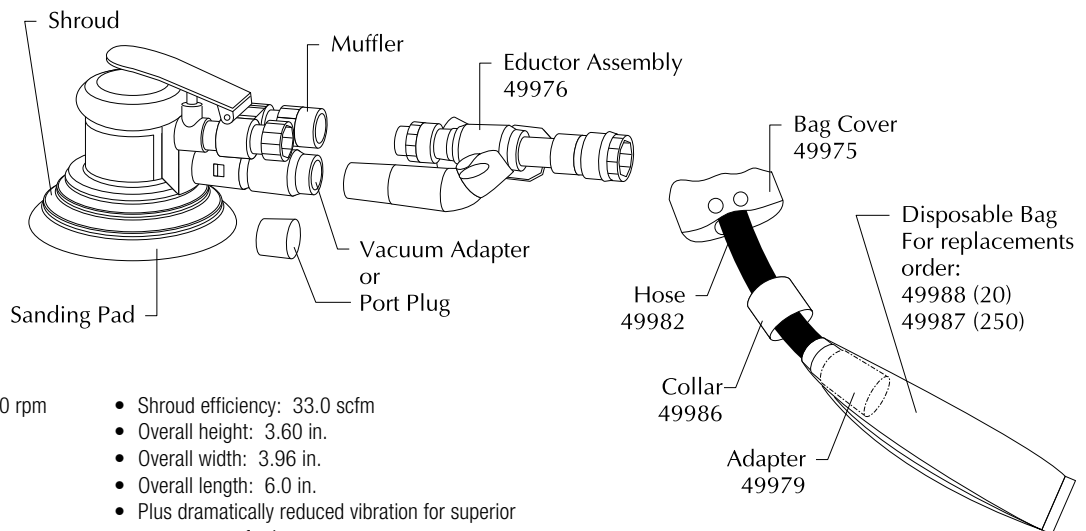

## Performance Data

- Maximum free speed: 12,000 rpm
- Power: 0.20 hp
- Air consumption: 15.8 scfm
- Sound pressure: 78 dBA
- Weight: 1.83 lbs.
- Power/weight: 0.109 hp/lb.
- Power/air consumption: 0.013 hp/scfm
- Shroud efficiency: 33.0 scfm
- Overall height: 3.60 in.
- Overall width: 3.96 in.
- Overall length: 6.0 in.
- Plus dramatically reduced vibration for superior operator comfort!

## ARO Elite and Jet Vac Model Identification Guide

Example: RS25A-PSV

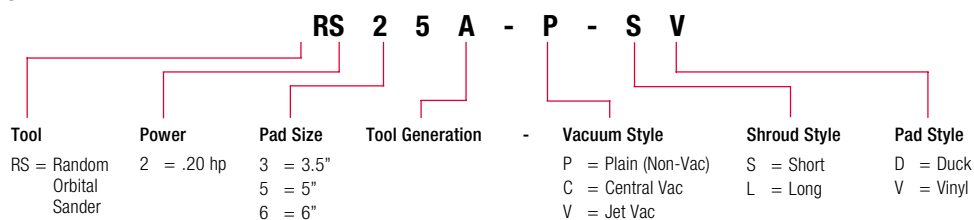

# Elite, Jet Vac and Classic Line Random Orbital Sanders Finishing Tools

## Elite Model Specifications

Model No.	Shroud Style	Pad Size		Pad Face	Rated Max Free Speed rpm	Power hp	Air Cons. @ Free Speed scfm	Spindle Thread (Female)	Weight	
		in.	mm						lbs	kg
<b>Non-Vacuum</b>										
RS23A-PLV	Long	3.5	89	Vinyl	12,000	.20	15.8	5/16"-24	1.77	.80
RS25A-PSD	Short	5	127	Duck	12,000	.20	15.8	5/16"-24	1.83	.83
• RS25A-PSV	Short	5	127	Vinyl	12,000	.20	15.8	5/16"-24	1.83	.83
RS26A-PSD	Short	6	152	Duck	12,000	.20	15.8	5/16"-24	1.92	.87
• RS26A-PSV	Short	6	152	Vinyl	12,000	.20	15.8	5/16"-24	1.92	.87
<b>Vacuum-Ready</b>										
RS23A-CLV	Long	3.5	89	Vinyl	12,000	.20	15.8	5/16"-24	1.77	.80
• RS25A-CSV	Short	5	127	Vinyl	12,000	.20	15.8	5/16"-24	1.83	.83
RS25A-CLV	Long	5	127	Vinyl	12,000	.20	15.8	5/16"-24	1.92	.87
RS26A-CSV	Short	6	152	Vinyl	12,000	.20	15.8	5/16"-24	1.92	.87
RS26A-CLV	Long	6	152	Vinyl	12,000	.20	15.8	5/16"-24	1.92	.87
<b>Jet Vac</b>										
RS23A-VLV	Long	3.5	89	Vinyl	12,000	.20	15.8	5/16"-24	1.86	.84
• RS25A-VLV	Long	5	127	Vinyl	12,000	.20	15.8	5/16"-24	1.92	.87
RS26A-VLV	Long	6	152	Vinyl	12,000	.20	15.8	5/16"-24	1.92	.87

- Most popular model

Sanding pads have industry-standard hole pattern for "thru-the-pad" vacuum pickup. For use with coated sanding discs with pre-punched holes.

Air Inlet: 1/4" NPT Female Recommended Air Pressure: 90 PSI (6.2 bar) Recommended Hose Size: 5/16" (8mm) I.D.

## CLASSIC™ LINE



Proven throughout thousands of industrial finishing applications, ARO has now refined its popular Classic Line models with stronger internal components, improved shrouds, and more efficient vacuum action. The "ARO red" cushion grip fits snugly over the aluminum housing, and provides a comfortable grip surface for the operator. ARO offers Classic Line models in standard size as well as "mini" size housings.

You can select non-vacuum models, vacuum-ready models for use with central or portable vacuum systems, and venturi-vacuum models with a self-contained hose and collection bag in the Classic Line. Classic Standard Non-vacuum models can be converted to vacuum-ready status with an available conversion kit. Refinements to shrouds and port diameters have not only improved vacuum performance, but have also reduced weight and sound levels. And, as with all ARO random orbital sanders, the Classic Line models require no lubrication, and are backed by an exclusive two-year warranty.

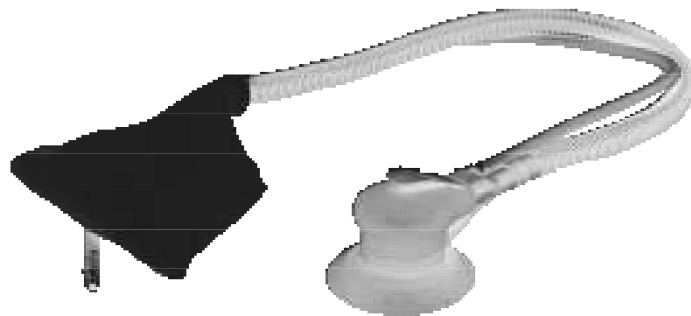

## ARO Classic Line Model Identification Guide

Example: 8416-B5T-V

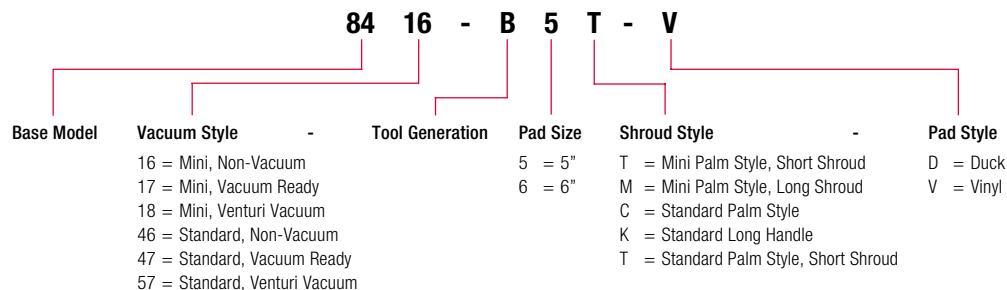

Classic Line Random Orbital Sanders  
**Finishing Tools**



8416-B5T-V



8446-B5C-V



8446-B6K-V

**Non-Vacuum**

Palm Style	Model No.		Pad Size		Pad Face	Rated Max Free Speed rpm	Power hp	Air Cons. @ Free Speed scfm	Spindle Thread (Female)	Weight			
	Long Handle		in.	mm						lbs	kg	lbs	kg
<b>Mini</b>													
					Duck	12,000	.20	12.5	5/16"-24	2.3	1.0	-	-
•	8416-B5T-V	-	5	127	Vinyl	12,000	.20	12.5	5/16"-24	2.3	1.0	-	-
	8416-B6T-D	-	6	152	Duck	12,000	.20	12.5	5/16"-24	2.3	1.0	-	-
	8416-B6T-V	-	6	152	Vinyl	12,000	.20	12.5	5/16"-24	2.3	1.0	-	-
<b>Standard</b>													
	8446-B5C-D	8446-B5K-D	5	127	Duck	10,000	.30	18.5	5/16"-24	2.3	1.0	2.6	1.2
•	8446-B5C-V	8446-B5K-V	5	127	Vinyl	10,000	.30	18.5	5/16"-24	2.3	1.0	2.6	1.2
	8446-B6C-D	8446-B6K-D	6	152	Duck	10,000	.30	18.5	5/16"-24	2.3	1.0	2.6	1.2
•	8446-B6C-V	8446-B6K-V	6	152	Vinyl	10,000	.30	18.5	5/16"-24	2.3	1.0	2.6	1.2

• Most popular model

Air Inlet: 1/4" NPT Female Recommended Air Pressure: 90 PSI (6.2 bar) Recommended Hose Size: 5/16" (8mm) I.D.



8417-B5T-V



8417-B5M-V



8447-E5T-V

**Vacuum-Ready**

Short Shroud	Model No.		Pad Size		Pad Face	Rated Max Free Speed rpm	Power hp	Air Cons. @ Free Speed scfm	Spindle Thread (Female)	Weight			
	Long Shroud		in.	mm						lbs	kg	lbs	kg
<b>Mini</b>													
•	8417-B5T-V	-	5	127	Vinyl	12,000	.20	12.5	5/16"-24	2.3	1.0		
	-	8417-B5M-V	5	127	Vinyl	12,000	.20	12.5	5/16"-24	2.3	1.0		
	8417-B6T-V	-	6	152	Vinyl	12,000	.20	12.5	5/16"-24	2.3	1.0		
	-	8417-B6M-V	6	152	Vinyl	12,000	.20	12.5	5/16"-24	2.3	1.0		
<b>Standard</b>													
•	8447-E5T-V	-	5	127	Vinyl	10,000	.30	18.5	5/16"-24	2.4	1.2		
•	8447-E6T-V	-	6	152	Vinyl	10,000	.30	18.5	5/16"-24	2.4	1.2		

• Most popular model

Sanding pads have industry-standard hole pattern for "thru-the-pad" vacuum pickup. For use with coated sanding discs with pre-punched holes.

Air Inlet: 1/4" NPT Female Recommended Air Pressure: 90 PSI (6.2 bar) Recommended Hose Size: 5/16" (8mm) I.D.



8418-B5T-V



8418-B5M-V



8457-B5T-V

**Venturi Vacuum**

Model No.		Pad Size		Pad Face	Rated Max Free Speed rpm	Power hp	Air Consp. @ Free Speed scfm	Spindle Thread (Female)	Weight	
Short Shroud	Long Shroud	in.	mm						lbs	kg
<b>Mini</b>										
8418-B5T-V	-	5	127	Vinyl	12,000	.20	12.5	5/16"-24	2.3	1.0
-	8418-B5M-V	5	127	Vinyl	12,000	.20	12.5	5/16"-24	2.3	1.0
8418-B6T-V	-	6	152	Vinyl	12,000	.20	12.5	5/16"-24	2.3	1.0
-	8418-B6M-V	6	152	Vinyl	12,000	.20	12.5	5/16"-24	2.3	1.0
<b>Standard</b>										
-	8457-B5T-V	5	127	Vinyl	10,000	.30	18.5	5/16"-24	2.4	1.1
-	8457-B6T-V	6	152	Vinyl	10,000	.30	18.5	5/16"-24	2.4	1.1

Sanding pads have industry-standard hole pattern for "thru-the-pad" vacuum pickup. For use with coated sanding discs with pre-punched holes.  
 Air Inlet: 1/4" NPT Female Recommended Air Pressure: 90 PSI (6.2 bar) Recommended Hose Size: 5/16" (8mm) I.D.

**Replacement Sanding Pads**

ARO premium sanding pads feature a riveted hub for increased stability throughout the life of the pad to help eliminate swirl marks. The special vinyl material provides greater consistency throughout the pads for smoother operation and increased durability. When combined with weight-matched counterbalances, ARO sanding pads produce the smoothest performance of any other random orbital sanding pad.

**Premium Quality, Low Profile Pads**

**Non-vacuum – 3/8" (9.5 mm) Thick**

- 49094 5" (127 mm) Dia., Vinyl Face "diamond" pattern. 49878 (Elite)
- 49095 5" (127 mm) Dia., Duck Face 49877 (Elite)
- 49097 6" (152 mm) Dia., Vinyl Face "diamond" pattern. 49879 (Elite)
- 49098 6" (152 mm) Dia., Duck Face 49880 (Elite)



**Vacuum<sup>1</sup> – 3/8" (9.5 mm) Thick**

- 49096 5" (127 mm) dia., Vinyl Face "petal" pattern.
- 49099 6" (152 mm) dia., Vinyl Face "petal" pattern.
- 04334009 3.5" Vinyl for all 3.5" Elite sanders (Non-vac, Vac-ready, and Jet-Vac).

**High Profile Pads**

**Non-vacuum – 5/8" (15.9 mm) Thick**

- 46860 5" (127 mm) Dia., Vinyl Face
- 46866 5" (127 mm) Dia., Duck Face
- 46861 6" (152 mm) Dia., Vinyl Face
- 46867 6" (152 mm) Dia., Duck Face



**Vacuum<sup>1</sup> – 5/8" (15.9 mm) Thick**

- 46862 5" (127 mm) Dia., Vinyl Face
- 46863 6" (152 mm) Dia., Vinyl Face

**Premium Quality, Hook and Loop**

**Low Profile Pads Non-vacuum and Vacuum**

- 49693 5" (127 mm) Dia. Hook and Loop Face
- 49694 6" (152 mm) Dia. Hook and Loop Face

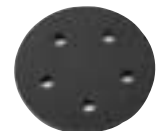

(1) For use with PSA coated sanding discs with industry-standard pre-punched holes.



**Orbital Sanders**

.3 HP (.2 kW)

Capacity: 3 2/3" x 9" Paper Size

- Compact size and light weight are ideal for sanding restricted areas or vertical surfaces.
- Low vibration and palm grip provide comfortable operation and minimize operator fatigue.
- Quick-change clamps enable fast, easy paper changes.

**Standard Equipment**

- Sanding Back-Up Pad

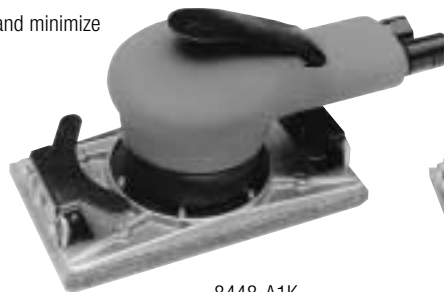

8448-A1K



8448-A1C

Model No.		Thickness		Pad Material	Free Speed rpm	Exhaust Location	Orbit Dia.		Air Cons. @ Free Speed		Sound Level @ Free Speed		Weight Part No.
Palm Grip	Long Handle	in.	mm				in.	mm	cfm	L/s	dBA		
<b>With Cushion Grip Sleeve</b>													
• 8448-A1C	8448-A1K	5/16	8	Felt	8000	Rear	.2	5.1	20	9	81	44570	
• 8448-A3C	8448-A3K	1/2	13	Sponge Rubber	8000	Rear	.2	5.1	20	9	81	44571	

- Most popular models

Description	Tool Height		Tool Weight	
	in.	mm	lbs	kg
Palm Grip	3.8	98	3.5	1.6
Long Handle	3.8	98	3.8	1.7

**Extra Cost Accessories**

For Model	Part No.	Description
8448	44360-()	Piped Exhaust Assembly

Air Inlet: 1/4" NPT Female  
 Recommended Air Pressure: 90 PSI (6.2 bar)  
 Recommended Hose Size: 5/16" (8mm) I.D.

ARO offers a complete line of service kits and specialty tools designed to extend the life of your random orbital sander and provide easy maintenance and service.

### Vacuum Hoses

- 44546-( ) Hose Assembly Equipped with necessary adapters. To order, add dash number to indicate desired length in feet.
- 49600 6' (1.8m) Hose Equipped with molded 1" I.D. cuffs at each end.
- 48275-1 Dust Collection Bag
- 49982 Hose Jet-Vac
- 49975 Bag Cover-Jet-Vac
- 49988 Disposable Bag (20)
- 49987 Disposable Bag (250)



### Vacuum Adapters/Conversion Kits

- 49802 Elite Series
- 49692 Classic Line
- 49977 Jet Vac-5"
- 49978 Jet Vac-6"

### Service Kits

Contain all the necessary genuine ARO replacement parts for proper preventative maintenance.

- 48894 (For all mini-size models produced before 12/1/93)
- 49837 (For mini and Elite models produced after 12/1/93)
- 48249-1 (For all standard-size models produced before 12/1/93)
- 49846 (For models produced after 12/1/93)

### Pad Wrenches

Use to remove sanding pad. Included with every tool.

- 30131 for standard non-vacuum models.
- 30131-2 for all mini and vacuum standard models.



### Spanner Wrenches

Use to remove the lock ring securing the motor assembly.

- 44548 for all standard models.
- 48869 for all mini models.



### Piped Exhaust Assembly

Channels exhausted air away from the immediate work area and reduces operating sound levels. Add dash number to indicate desired length in feet.

- 44360-( ) for all models.



### Grip Rings

Alternate grip rings for Elite Series models.

- 49801 Small, Grey
- 49798 Medium, Black
- 49799 Large, Blue
- 49840 Kit of 3

### Counter Balance - RS Series

- 04333100 Needle Bearing Puller

Elite Grinders / Sanders / Polishers  
**Finishing Tools**



**Simple, Modular, Efficient**

ARO developed the Elite line with patented full-flow steel motor cylinders to provide maximum air utilization and generate more torque. With few moving parts and extensive parts commonality, costly downtime associated with routine maintenance is reduced dramatically. Your parts inventory is also reduced as you can interchange parts as you need them.



**Elite Grinders / Sanders / Polishers**

**Ergonomic Innovations**

Elite's D-shaped housing was designed to fit comfortably in the operator's hand to help minimize the amount of gripping force required. The spoon-shaped throttle conforms to the tool housing to eliminate irritating pressure points in the palm of the hand. To protect operator's hands, the high-profile safety flange guards against accidental throttle actuation.

**Small Size. Large Selection**

Based on innovative ergonomic advancements, ARO's Elite Series grinders/sanders and polishers are smaller in size, easier to hold, and more comfortable to use than competitive models. Available in straight, angle, and extended styles, these tools offer a range of operating speeds to ensure that there's a right tool for every job from light polishing to heavy material removal.



Patented "drop-in" motor design requires no alignment or shims, and enables quick, easy blade replacement.



Innovative Ergonomic Handle Styling



Spoon-Shaped Lever Throttle



High-Profile Safety Flange

# Elite Die Grinders Finishing Tools

Rated Power: 0.20 to 1.0 hp (0.15 to 0.75 kW)



GH03A-35RC-2

## Standard Equipment

- 1/4" Erikson Collet  
49450 - 40 (GH074 and GH10A)  
49440 - 29 (GH03A)
- 7/16" Collet Body Wrench  
49440 - 52
- 11/16" Collet Nut Wrench  
49440 - 51

## Model Identification Guide

Example: GHX03A-30FC-2-P

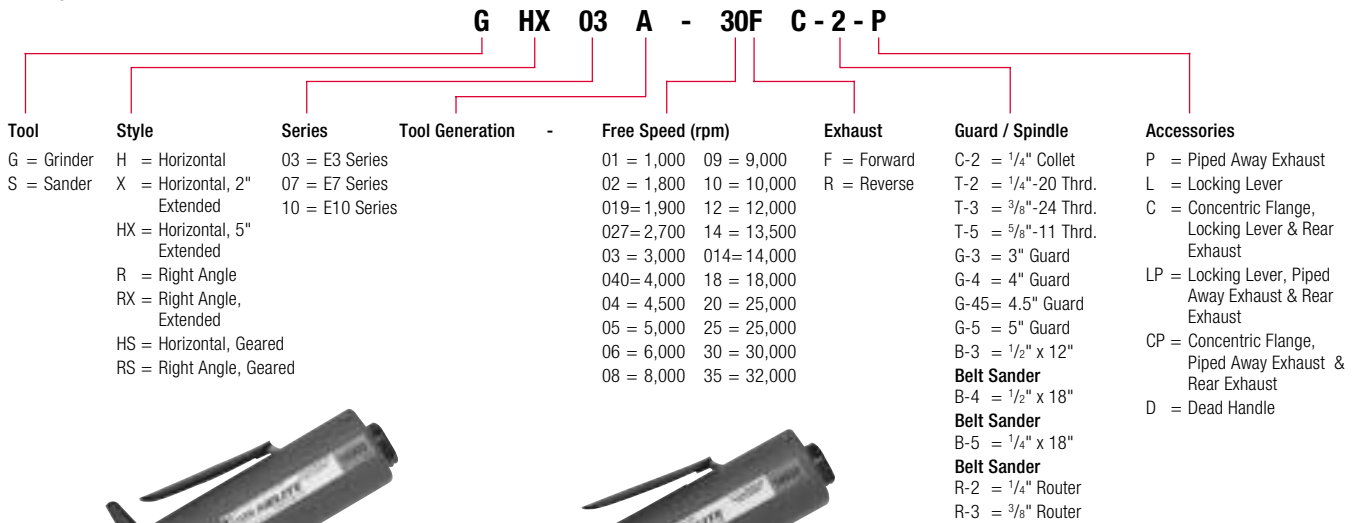

GH07A-18RC-2



GH10A-18RC-2

## Elite Die Grinders

Model No.	Free Speed rpm	Rated Power hp kW	Collet Size in. mm	Spindle Offset in. mm	Overall Length in. mm	Weight lbs kg	Sound Level <sup>1</sup> dB(A)	Air Consp. @ Free Speed cfm L/s	Abrasive Type and Capacity
<b>E3 Series</b>									
GH03A-35(J)C-2	32,000	0.35 0.26	1/4 6	0.75 19	6.2 157	0.8 0.37	77	15 7.1	
GH03A-30(J)C-2	30,000	0.30 0.22	1/4 6	0.75 19	6.2 157	0.8 0.37	74	14 6.6	
GH03A-25(J)C-2 <sup>2</sup>	25,000	0.24 0.18	1/4 6	0.75 19	6.2 157	0.8 0.37	74	12 5.7	
GH03A-20(J)C-2	20,000	0.20 0.15	1/4 6	0.75 19	6.2 157	0.8 0.37	70	11 5.2	
GHX03A-25(J)C-2	25,000	0.24 0.18	1/4 6	0.75 19	9.2 233	1.2 0.54	74	12 5.7	
GHX03A-30(J)C-2	30,000	0.30 0.22	1/4 6	0.75 19	9.2 233	1.2 0.54	74	14 6.6	
<b>E7 Series</b>									
GH07A-25(J)C-2 <sup>2</sup>	25,000	0.70 0.52	1/4 6	0.75 19	7.75 196	1.6 0.73	78	26 12.3	1 1/2" Mtd. Stone
GH07A-20(J)C-2	20,000	0.56 0.42	1/4 6	0.75 19	7.75 196	1.6 0.73	77	24 11.3	1 1/2" Mtd. Stone
GH07A-18(J)C-2	18,000	0.50 0.37	1/4 6	0.75 19	7.75 196	1.6 0.73	76	23 10.9	1 1/2" Mtd. Stone
GH07A-12(J)C-2	12,000	0.33 0.24	1/4 6	0.75 19	7.75 196	1.6 0.73	74	20 9.4	2" Mtd. Stone
<b>E10 Series</b>									
GH10A-18(J)C-2 <sup>2</sup>	18,000	1.0 0.75	1/4 6	0.97 25	8.6 218	1.9 0.85	77	43 20.3	1 1/2" Mtd. Stone
GH10A-12(J)C-2	12,000	0.72 0.54	1/4 6	0.97 25	8.6 218	1.9 0.85	77	34 16.0	2" Mtd. Stone

Rear exhaust direction is standard. For front exhaust change model number to read "FC". refer to Model Identification Guide.

Low profile flange is only available with locking lever and rear exhaust.

All models have a 1/4" NPT Air Inlet. Recommended Hose Size: 5/16" (8 mm) for E3 and E7 Series, 3/8" (10 mm) for E10 Series.

(1) dB(A) measurement includes use of Overhose Exhaust Assembly.

(2) Add 'K' after 'A' to get kit which includes tool, plastic carrying case, 4 burs and exhaust hose.



Toll-Free 1-866-763-6226 Phone: 905-672-5557  
Fax: 905-672-5559 Email: sales@dobcoeqp.com

Elite Horizontal Grinders and Sanders  
**Finishing Tools**

Rated Power: 0.24 to 0.9 hp (0.37 to 0.7 kW)



**Standard Equipment**

- Wheel Guard, Flanges and Nut (GH03A & GH07A)
- 1/4" Erikson Collet 49450-40 (GH507A & GH510A)
- Collet Body Wrench 49450-37 (GH507A & GH510A)
- Collet Nut Wrench 49450-38 (GH507A & GH510A)



GH03A-20RG-3



GHS10A-03RC-2

**Elite Horizontal Grinders and Sanders**

Model No.	Free Speed rpm	Rated Power		Collet Size		Spindle Offset		Overall Length		Weight		Sound Level <sup>1</sup> dB(A)	Air Cons. @ Free Speed		Wheel Abrasive Type and Capacity
		hp	kW	in.	mm	in.	mm	in.	mm	lbs	kg		cfm	L/s	
<b>E3 Series with Guard</b>															
GH03A-20()G-3	20,000	0.24	0.18	3/8-24	—	0.75	19	10.5	267	1.5	0.7	74	11	5.2	Type 1 - 3" x 1/4"
<b>E7 Series with Guard</b>															
GX07A-18()G-3	18,000	0.5	0.37	3/8-24	—	1.2	30	12.2	313	3.2	1.5	76	23	10.9	Type 1 - 3" x 1/4"
<b>E10 Series with Collet</b>															
GHS10A-05()C-2	4,500	0.9	0.7	1/4	6	1.2	30	12.9	328	3.8	1.7	82	43	20.3	Wire Brush Wheels Flap Wheels Buffing Wheels Non-Woven Abrasive
GHS10A-03()C-2	3,000	0.9	0.7	1/4	6	1.2	30	12.9	328	3.8	1.7	81	43	20.3	
GHS10A-01()C-2	1,000	0.9	0.7	1/4	6	1.2	30	13.75	349	4.1	1.9	79	43	20.3	

Rear exhaust direction is standard. For front exhaust change model number to read "FC". refer to Model Identification Guide.

Low profile flange is only available with locking lever and rear exhaust.

All models have a 1/4" NPT Air Inlet. Recommended Hose Size: 5/16" (8 mm) for E3 and E7 Series, 3/8" (10 mm) for E10 Series.

(1) dB(A) measurement includes use of Overhose Exhaust Assembly.



# Elite Angle Grinders and Sanders

## Finishing Tools

Rated Power: 0.24 to 1.0 hp (0.18 to 0.75 kW)



GR03A-20RC-2



GRX07A-14RC-2



GR10A-12RC-2



GR10A-12RG-4

### Standard Equipment

- Wheel Guard, Flanges and Nut (GR10A & GRX10A)
- Spindle and Wheel Nut Wrenches
- 1/4" Erikson Collet  
49440-29 (GR03A)  
49450-40 (GR07A & GR10A)
- Collet Body Wrench  
49440-52 (GR03A)  
49450-37 (GR07A & GR10A)
- Collet Nut Wrench  
49440-51 (GR03A)  
49450-38 (GR07A, GRX07A, GR10A & GRX10A)

### Elite Angle Grinders and Sanders

Model No.	Free Speed rpm	Rated Power hp kW	Collet Size in. mm	Spindle Offset in. mm	Angle Height in. mm	Overall Length in. mm	Weight lbs kg	Sound Level <sup>1</sup> dB(A)	Air Consp. @ Free Speed cfm L/s	Wheel Abrasive Type and Capacity
<b>E3 Series with Collet</b>										
GR03A-20(J)C-2	20,000	0.30 0.22	1/4 6	0.75 19	- -	6.1 154	1.1 0.51	74	14 6.6	1" Carb. Burr, 1" Mtd. Stone 2" or 3" Sanding Pad
GR03A-12(J)C-2	12,000	0.24 0.18	1/4 6	0.75 19	- -	6.1 154	1.1 0.51	74	12 5.7	
<b>E7 Series with Collet</b>										
GR07A-18(J)G-3	18,000	0.70 0.52	3/8-24 -	0.75 19	2.5 64	7.7 195	2.6 1.2	77	26 12.3	1" Carb. Burr, 1" Mtd. Stone 3" Sanding Pad
GR07A-12(J)G-4	12,000	0.56 0.42	3/8-24 -	0.75 19	2.5 64	7.7 195	2.7 1.2	76	26 12.3	
GRX07A-14(J)G-4	13,500	0.56 0.42	3/8-24 -	0.75 19	2.3 59	10.4 264	2.9 1.3	76	25 11.8	
<b>E7 Series with Guard</b>										
GR07A-18(J)G-3	18,000	0.70 0.52	3/8-24 -	0.75 19	2.5 64	7.7 195	2.6 1.2	77	26 12.3	3" Type 27 and 28 4" Type 27 and 28
GR07A-12(J)G-4	12,000	0.56 0.42	3/8-24 -	0.75 19	2.5 64	7.7 195	2.7 1.2	76	26 12.3	
GRX07A-14(J)G-4	13,500	0.56 0.42	3/8-24 -	0.75 19	2.3 59	10.4 264	2.9 1.3	76	25 11.8	4" Type 27 and 28
<b>E10 Series with Collet</b>										
GR10A-12(J)C-2	12,000	0.83 0.61	1/4 6	0.8 21	3.0 76	8.8 224	3.1 1.4	82	43 20.3	1" Carb. Burr, 1" Mtd. Stone 3" Sanding Pad
<b>E10 Series with Guard</b>										
GR10A-12(J)G-4	12,000	1.0 0.75	3/8-24 -	0.8 21	2.5 64	8.8 224	3.1 1.4	80	43 20.3	4" Type 27 and 28 4 1/2" Type 27 and 28
GRX10A-12(J)G-4-D	12,000	1.0 0.75	3/8-24 -	0.8 21	2.5 64	11.2 284	3.9 1.7	80	43 20.3	
GRX10A-12(J)G-45-D	12,000	1.0 0.75	5/8-11 -	0.8 21	2.5 64	11.2 284	3.9 1.7	80	43 20.3	

Rear exhaust direction is standard. For front exhaust change model number to read "FC". refer to Model Identification Guide.

Low profile flange is only available with locking lever and rear exhaust.

All models have a 1/4" NPT Air Inlet. Recommended Hose Size: 5/16" (8 mm) for E3 and E7 Series, 3/8" (10 mm) for E10 Series.

(1) dB(A) measurement includes use of Overhose Exhaust Assembly.



Toll-Free 1-866-763-6226 Phone: 905-672-5557  
Fax: 905-672-5559 Email: sales@dobcoeqp.com

# Elite Angle Sanders and Polishers / Belt Sanders

## Finishing Tools

**Rated Power: 0.24 to 0.9 hp (0.18 to 0.75 kW)**

### Standard Equipment

- Ergo Handle (GRS07A & GRS10A)

### Accessories

- Safety Locking Lever (LG2-A400)
- Piped Away Exhaust Kit (LG2-K284)
- Low-Profile Concentric Flange (LG3R-23)
- 5" Medium Sanding Pad (77A-AM8525-5)
- 7" Medium Sanding Pad (77A-AM8525-7)
- 7" Firm Sanding Pad (77A-BM8525-7)
- 3" Pad (LG1-K3)
- 2" Pad (LG1-K2)



### Elite Angle Sanders and Polishers

Model No.	Free Speed rpm	Rated Power		Spindle Thread		Spindle Offset		Overall Length		Weight		Sound Level <sup>1</sup> dB(A)	Air Consp. @ Free Speed		Pad Size
		hp	kW	in.	mm	in.	mm	in.	mm	lbs	kg		cfm	L/s	
<b>E3 Series</b>															
GR03A-20(JT-2)	20,000	0.3	0.22	.25	20	0.75	19	6.1	154.00	1.1	0.5	74	15	7.1	See Note 2
GR03A-12(JT-2)	12,000	0.24	0.18	.25	20	0.75	19	6.1	154.00	1.1	0.5	74	12	5.7	See Note 2
<b>E10 Series</b>															
SRX10A-019RT-5	1,900	1.0	.75	.63	11	1.19	30	13.38	339.85	4.56	2.06	84.8	43	20.3	See Note 2
SRX10A-027RT-5	2,700	1.0	.75	.63	11	1.19	30	13.38	339.85	4.56	2.06	87.4	43	20.3	See Note 2
SRS10A-040RC-2	4,000	1.0	.75	.25	20	1.19	30	8.81	223.77	2.63	1.19	85.5	43	20.3	See Note 2
SRS10A-040RT-5	4,000	1.0	.75	.63	11	1.19	30	8.81	223.77	2.63	1.19	86.3	43	20.3	See Note 2
SRS10A-05RT-5	5,000	1.0	.75	.63	11	1.19	30	8.81	223.77	2.63	1.19	85.0	43	20.3	See Note 2
SRS10A-060RC-2	6,000	1.0	.75	.25	20	1.19	30	8.81	223.77	2.63	1.19	86.1	43	20.3	See Note 2
SRS10A-06RT-5	6,000	1.0	.75	.63	11	1.19	30	8.81	223.77	2.63	1.19	88.1	43	20.3	See Note 2
SRX10A-06RT-5	6,000	1.0	.75	.63	11	1.19	30	11.81	299.97	3.31	1.50	85.1	43	20.3	See Note 2
SRS10A-08RT-5	8,000	1.0	.75	.63	11	1.19	30	8.81	223.77	2.63	1.19	87.1	43	20.3	See Note 2
SRX10A-08RT-5	8,000	1.0	.75	.63	11	1.19	30	11.81	299.97	3.31	1.50	84.6	43	20.3	See Note 2
SRS10A-10RT-5	10,000	1.0	.75	.63	11	1.19	30	8.81	223.77	2.63	1.19	85.1	43	20.3	See Note 2
SRX10A-10RT-5	10,000	1.0	.75	.63	11	1.19	30	11.81	299.97	3.31	1.50	84.4	43	20.3	See Note 2
SRS10A-12RT-5	12,000	1.0	.75	.63	11	1.19	30	8.81	223.77	2.63	1.19	86.2	43	20.3	See Note 2
SRX10A-12RT-5	12,000	1.0	.75	.63	11	1.19	30	11.81	299.97	3.31	1.50	84.4	43	20.3	See Note 2
SRS10A-014RT-5	14,000	1.0	.75	.63	11	1.19	30	8.81	223.77	2.63	1.19	87.3	43	20.3	See Note 2

All models have a 1/4" NPT Air Inlet. Recommended Hose Size: 5/16" (8 mm) for E3 and E7 Series, 3/8" (10 mm) for E10 Series.  
 (1) dB(A) measurement includes use of Overhose Exhaust Assembly.  
 (2) Order Sanding Pad separately at extra cost.

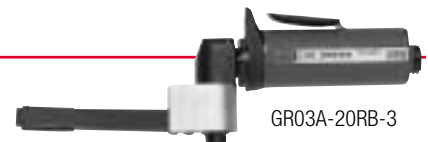

### Belt Sanders – Rated Power 0.24 - 1.0 hp (0.18 - 0.75 kW)

Model No.	Free Speed rpm	Rated Power		Standard Thread	Spindle Offset		Length w/ Belt Attachment		Weight		Sound Level <sup>1</sup> dB(A)	Air Consp. @ Free Speed		Belt Size in.	
		hp	kW		in.	mm	in.	mm	lbs	kg		cfm	L/s		
<b>E3 Series</b>															
GR03A-20(JB-3)	20,000	0.3	0.22	1/4" Collet	0.75	19	10.75	273	1.5	0.7	74	12	5.7	1/2" x 12"	
GR03A-12(JB-3)	12,000	0.24	0.18	1/4" Collet	0.75	19	10.75	273	1.5	0.7	74	12	5.7	1/2" x 12"	
GR03A-20(JB-4)	20,000	0.3	0.22	1/4" Collet	0.75	19	14	273	1.75	0.7	74	12	5.7	1/2" x 18"	
GR03A-12(JB-4)	12,000	0.24	0.18	1/4" Collet	0.75	19	14	273	1.75	0.7	74	12	5.7	1/2" x 18"	
GR03A-20(JB-5)	20,000	0.3	0.22	1/4" Collet	0.75	19	14	273	1.63	0.7	74	12	5.7	1/4" x 18"	
GR03A-12(JB-5)	12,000	0.24	0.18	1/4" Collet	0.75	19	14	273	1.63	0.7	74	12	5.7	1/4" x 18"	

Rear exhaust direction is standard. For front exhaust change model number to read "FC", refer to Model Identification Guide.  
 Low profile flange is only available with locking lever and rear exhaust. All models have a 1/4" NPT Air Inlet. Recommended Hose Size: 5/16" (8 mm).  
 (1) dB(A) measurement includes use of Overhose Exhaust Assembly.

# Elite Routers and Accessories

## Finishing Tools

**Rated Power: 0.24 to 1.0 hp (0.18 to 0.75 kW)**

### Standard Equipment

- Erickson Collet
- Collet Body
- Collet Nut Wrench
- Coupling Nut Wrench



GH07A-18RR-2 (Trimmer Guide not included)

### Routers

Model No.	Free Speed rpm	Rated Power hp kW	Standard Thread	Spindle Offset in. mm	Length w/ Belt Attachment in. mm	Weight lbs kg	Sound Level <sup>1</sup> dB(A)	Air Cons. @ Free Speed cfm L/s	Belt Size in.
<b>E7 Series</b>									
GH07A-20(JR)-2	20,000	0.56 0.42	1/4" Collet	0.75 19	8.4 213	2.4 11	77	24 11.3	1/4" 6.4
GH07A-25(JR)-2	25,000	0.7 0.52	1/4" Collet	0.75 19	8.4 213	2.4 11	78	26 12.3	1/4" 6.4
<b>E10 Series</b>									
GH10A-18(JR)-2	18,000	1.0 0.75	1/4" Collet	0.97 24	9.2 234	2.5 11	76	43 20.3	1/4" 6.4

All models have a 1/4" NPT Air Inlet. Recommended Hose Size: 5/16" (8 mm).  
 (1) dB(A) measurement includes use of Overhose Exhaust Assembly.

### Extra Cost Accessories

Part No.	For Bits with Shank Size	A	B	C	D
R120-128-2	1/4"	1 1/2"	3/8"	3/8"	1/8"
R120-128-7	1/4"	2 1/2"	1/2"	1/2"	3/16"
LG2-129-1	3/8"	2 1/2"	1/2"	5/8"	1/8"

Guides for 1/4" models have 1/2" - 20 UNF thread.  
 Guides for 3/8" models have 3/8" - 18 UNF thread.

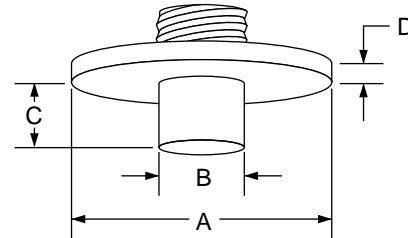

Trimmer Guides

### Lock-Off Lever

- LG1-A400 for E3 Series models
- LG2-A400 for E7 and E10 models

### Belt Sanders Attachment for GR03A-( ) C-2

- LG1-A350-812 1/2" X 12" Attachment
- LG1-A350-818 1/2" X 18" Attachment
- LG1-A350-418 1/4" X 18" Attachment

### Ergo Side Handle

- 49461 for E7 and E10 Series Angle Grinders and Sanders

### Router Attachments

- 1/4" Router Attachment – TD-RK4 for E7 and E10
- 3/8" Router Attachment – TD-RK6 for E7 and E10



### Overhose/Speed Control Kit

A combination air inlet bushing with an adjustable speed regulator valve and 2 1/2 ft. (0.76 mm) pipe-away exhaust hose.

- LG1-A1015 for all E3 Series models

### Exhaust Hose Kit

- LG1-K284 (E3)
- LG2-K284 (E7 & E10)

### Front Exhaust Flange

- LG1-23 (E3)
- LG2-23 (E7 & E10)

### Rear Exhaust Flange

- ALG1-23

### Concentric Flange

- LG1R-23 (E3)
- LG3R-23 (E7 & E10)

### Vacuum Shroud 3" for GR03A-( )T-2 or C-2

- LA1-K975 for T-2
- LA1-K980 for C-2

### Collets

- 1/8" Erickson DG110-700-G2
- 1/4" Erickson G160HD-700-1/4
- 3/8" Erickson DG120-700-G6  
(Available Only For #07A & #10A Units)

Rear exhaust direction is standard. For front exhaust change model number to read "FC". refer to Model Identification Guide.  
 Low profile flange is only available with locking lever and rear exhaust.



**Toll-Free 1-866-763-6226 Phone: 905-672-5557**  
**Fax: 905-672-5559 Email: sales@dobcoeqp.com**

# Elite Heavy Duty Grinders

## Finishing Tools



### New from ARO!

The Elite Series heavy duty models are designed for production and maintenance application involving heavy material removal and large workpieces. Available in horizontal, right angle, and vertical configurations, these 0.8 to 2.2 horsepower models include grinders, sanders, and polishers. They deliver superior power with lower air consumption than competitive models, and feature significant operator advantages.



### Model Identification Guide

Example: GVG21-A-06F-6

Tool	Style	Type	Power	Version	Free Speed (rpm)	Guard / Spindle
G = Grinder	H = Horizontal V = Vertical R = Right Angle	G = Grinder P = Polisher S = Sander	08 = .08 hp 15 = 1.5 hp 18 = 1.8 hp 20 = 2.0 hp 21 = 2.1 hp 22 = 2.2 hp	M = Metric A = English	01 = 2,400/2,500 02 = 3,000 04 = 4,500 05 = 4,800/5,000 06 = 6,000 08 = 7,500/7,700 09 = 9,000 12 = 12,000	D-2 = Cone Spindle, 5/8"-11 F-2 = 6" Guard Type 6/11, 5/8"-11 G-3 = 3" Guard Type 1, 3/8"-24 G-4 = 4" Guard Type 1, 1/2"-13 G-6 = 6" Guard Type 1, 5/8"-11 G-7 = 6" Guard Type 27/28 G-9 = 6" Guard Type 27/28 L-5 = 5/8" Spindle P-7 = 7" Polishing Bonnet, 5/8"-11 S-7 = 7" Back-Up Pad, 5/8"-11 S-9 = 9" Back-Up Pad, 5/8"-11

### Motor Controller

The ARO Elite Heavy Duty finishing tools incorporate a patented motor controller which is designed to increase productivity while enhancing operator safety. The controller regulates air flow through the end plate and into the motor to control the speed and power of the tool. There is no need for an additional over-speed shut-off device.



### Locking Throttle Lever

The ARO locking throttle lever is a spring-loaded latch that resets each time the lever is released. This unique system prevents accidental throttle operation — even if the tool is dropped.



### Integral Guards

Elite Heavy Duty grinders are equipped with patented integral guards that prevent the tool from operating if they are removed. When removed, the tool's motor is not properly supported, and the tool will not operate. Cup-wheel type grinding tools have the exclusive 180° integral guard for better visibility and greater wheel utilization. All guards are made of steel for extra protection.



### Adjustable Handles

Elite Heavy Duty vertical grinders incorporate adjustable side handles that can be easily adjusted to 90° to 120° for ease of handling and better control. For increased operator comfort, the ergonomic handle design makes it easy for the operator to hold and use the tool — even with gloved hands.



# Elite Heavy Duty Horizontal Grinders

## Finishing Tools

**Rated Power: 1.5 to 2.2 hp (1.2 to 1.6 kW)**



GH15A-05L-5



GH15A-12D-5



GH15A-12G-3



GH20A-06G-6

### Standard Equipment

- Wheel Guard, Flanges and Nut
- Powerful, efficient 1.5, 2.2, and 2.0 horsepower motors.
- Patented stainless steel motor controller, backed by a lifetime guarantee.
- Self-locking throttle levers prevent accidental operation.
- Integral steel guard provides operator protection.
- Built-in mist lubricator automatically oils motor each time tool is operated.

### Elite Heavy Duty Grinders

Model No.	Free Speed rpm	Rated Power		Exhaust Location	Spindle	Spindle Housing Dia.		Tool Length		Tool Weight		Air Consumption @ Free Speed	
		hp	kW			in.	mm	in.	mm	lbs	kg	cfm	L/s
<b>Spindle Models</b>													
GH15A-03L-5	3,000	1.5	1.2	Side	5/8"-11 x 2"	1 <sup>5</sup> / <sub>16</sub>	33.3	17 <sup>11</sup> / <sub>16</sub>	449	7 <sup>5</sup> / <sub>16</sub>	3.3	37	17.5
GH15A-05L-5	5,000	1.5	1.2	Side	5/8"-11 x 2"	1 <sup>5</sup> / <sub>16</sub>	33.3	17 <sup>11</sup> / <sub>16</sub>	449	7 <sup>5</sup> / <sub>16</sub>	3.3	39	18.4
<b>Cone Spindle Models</b>													
GH15A-09D-5	9,000	1.5	1.2	Side	5/8"-11	1 <sup>7</sup> / <sub>8</sub>	47.6	16 <sup>7</sup> / <sub>16</sub>	418	6	2.7	37	17.5
GH15A-12D-5	12,000	1.5	1.2	Side	5/8"-11	1 <sup>7</sup> / <sub>8</sub>	47.6	16 <sup>7</sup> / <sub>16</sub>	418	6	2.7	39	18.4
GH22A-09D-5	9,000	2.2	1.6	Side	5/8"-11	2 <sup>1</sup> / <sub>4</sub>	57.2	18 <sup>1</sup> / <sub>4</sub>	464	8 <sup>3</sup> / <sub>8</sub>	3.8	66	31.2
<b>Type 1 Wheel Models</b>													
GH15A-09G-4	9,000	1.5	1.2	Side	1/2"-13	2 <sup>5</sup> / <sub>8</sub>	66.7	17 <sup>1</sup> / <sub>4</sub>	438	6 <sup>1</sup> / <sub>2</sub>	2.9	37	17.5
GH15A-12G-3	12,000	1.5	1.2	Side	3/8"-24	2 <sup>5</sup> / <sub>8</sub>	66.7	16 <sup>5</sup> / <sub>8</sub>	422	6 <sup>1</sup> / <sub>8</sub>	2.8	39	18.4
GH15A-12G-4	12,000	1.5	1.2	Side	1/2"-13	2 <sup>5</sup> / <sub>8</sub>	66.7	17 <sup>1</sup> / <sub>4</sub>	438	6 <sup>1</sup> / <sub>2</sub>	2.9	39	18.4
GH20A-06G-6	6,000	2.0	1.5	Side	5/8"-11	3 <sup>3</sup> / <sub>8</sub>	85.7	20	508	11 <sup>5</sup> / <sub>16</sub>	5.3	61	28.8

Air Inlet: 3/8" NPT (GH15A) (Models GH22A, GH20A: 1/2" NPT)  
 Recommended Hose Size: 1/2" (GH15A) (Models GH22A, GH20A: 3/4")  
 Performance Figures are at 90 PSI air pressure



Elite Heavy Right-Angle Tools  
**Finishing Tools**

Rated Power: 2,500 to 7,500 rpm / 1.5 hp (1.2 kW)



GRP15A-02P-7



GRG15A-06G-7

**Standard Equipment**

- Powerful, efficient 1.5 horsepower motors.
- Patented stainless steel motor controller, backed by a lifetime guarantee.
- Self-locking throttle lever prevents accidental operation.
- Integral steel guard on wheel models provides operator protection.
- Built-in mist lubricator automatically oils motor each time tool is operated.
- Back-Up Pads  
 49845 - 224 - 5"  
 49845 - 225 - 7" Medium  
 49845 - 226 - 7" Firm  
 49845 - 227 - 9"
- Polishing Bonnet (GRP15A - 02P - 7 Only)  
 49842 - 141 Depressed Center Wheel / Type 27 and 28 Wheel

**Elite Heavy Duty Right-Angle Tools**

Model No.	Free Speed rpm	Rated Power hp kW	Exhaust Location	Spindle	Height Over End of Spindle/Arbor in. mm	Side to Center Dist. at of Spindle/Arbor in. mm	Tool Length in. mm	Tool Weight lbs kg	Air Consumption @ Free Speed cfm L/s
<b>Models</b>									
GRG15A-06G-7	6,000	1.5 1.2	Side	5/8"-11	3 3/4 95.2	1 5/16 33.3	17 9/16 446	9 4.1	39 18.4
GRG15A-06G-9	6,000	1.5 1.2	Side	5/8"-11	3 3/4 95.2	1 5/16 33.3	17 9/16 446	9 3/16 4.2	39 18.4
GRG15A-08G-7	7,500	1.5 1.2	Side	5/8"-11	3 3/4 95.2	1 5/16 33.3	17 9/16 446	9 4.1	39 18.4
<b>Sanders and Polishers</b>									
GRS15A-04S-9	4,500	1.5 1.2	Side	5/8"-11	3 3/4 95.2	1 5/16 33.3	17 9/16 446	7 13/16 3.5	37 17.5
GRS15A-06S-7	6,000	1.5 1.2	Side	5/8"-11	3 3/4 95.2	1 5/16 33.3	17 9/16 446	7 13/16 3.5	39 18.4
GRP15A-02P-7	2,500	1.5 1.2	Side	5/8"-11	3 3/4 95.2	1 5/16 33.3	17 9/16 446	8 3/8 3.8	37 17.5

Air Inlet: 3/8" NPT Recommended Hose Size: 1/2" Performance Figures are at 90 PSI air pressure

# Elite Heavy Duty Vertical Tools Finishing Tools

Rated Power: 2,400 to 7,700 rpm / 0.8 to 2.0 hp (0.6 to 1.6 kW)



GVG21A-06G-7



GVG21A-06F-6

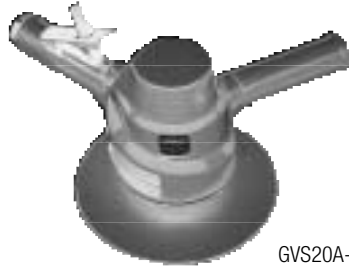

GVS20A-06S-7



GV08A-02P-7

## Standard Equipment

- Powerful, efficient .08 – 2.2 horsepower motors.
- Patented stainless steel motor controller, backed by a lifetime guarantee.
- Self-locking throttle lever prevents accidental operation.
- Integral steel guard provides operator protection.
- Built-in mist lubricator automatically oils motor each time tool is operated.
- Back-Up Pads
- Polishing Bonnet (GV08A - 02P - 7 Only)

## Elite Heavy Duty Vertical Tools

Model No.	Free Speed rpm	Rated Power hp	Rated Power kW	Exhaust Location	Spindle	Height Over End of Spindle/Arbor in.	Height Over End of Spindle/Arbor mm	Side to Center Dist. at of Spindle/Arbor in.	Side to Center Dist. at of Spindle/Arbor mm	Tool Weight lbs	Tool Weight kg	Air Consumption @ Free Speed cfm	Air Consumption @ Free Speed L/s
<b>Type 6 and 11 Wheel Model</b>													
GVG21A-06F-6	6,000	2.1	1.60	Side	5/8"-11	6 <sup>3</sup> / <sub>32</sub>	15.5	2 <sup>1</sup> / <sub>8</sub>	53.9	8 <sup>3</sup> / <sub>8</sub>	3.8	61	28.8
<b>Type 27 and 28 Wheel Model</b>													
GVG21A-06G-7	6,000	2.1	1.60	Side	5/8"-11	6 <sup>3</sup> / <sub>32</sub>	15.5	2 <sup>1</sup> / <sub>8</sub>	53.9	8 <sup>3</sup> / <sub>4</sub>	4.0	61	28.8
GVG21A-06G-9	6,000	2.1	1.60	Side	5/8"-11	6 <sup>3</sup> / <sub>32</sub>	15.5	2 <sup>1</sup> / <sub>8</sub>	53.9	9 <sup>1</sup> / <sub>16</sub>	4.1	61	28.8
GVG22A-08G-7	7,700	2.2	1.65	Side	5/8"-11	6 <sup>3</sup> / <sub>32</sub>	15.5	2 <sup>1</sup> / <sub>8</sub>	53.9	8 <sup>3</sup> / <sub>4</sub>	4.0	68	32.1
<b>Sanders and Polishers</b>													
GV08A-02P-7	2,400	0.80	0.60	Side	5/8"-11	6 <sup>3</sup> / <sub>8</sub>	16.2	1 <sup>3</sup> / <sub>16</sub>	30.2	3 <sup>1</sup> / <sub>4</sub>	1.5	22	10.4
GV08A-03S-7	3,000	0.80	0.60	Side	5/8"-11	6 <sup>3</sup> / <sub>8</sub>	16.2	1 <sup>3</sup> / <sub>16</sub>	30.2	3 <sup>1</sup> / <sub>4</sub>	1.5	22	10.4
GV08A-05S-7	4,800	0.80	0.60	Side	5/8"-11	6 <sup>3</sup> / <sub>8</sub>	16.2	1 <sup>3</sup> / <sub>16</sub>	30.2	3 <sup>1</sup> / <sub>4</sub>	1.5	22	10.4
GV08A-06S-7	6,000	0.80	0.60	Side	v-11	6 <sup>3</sup> / <sub>8</sub>	16.2	1 <sup>3</sup> / <sub>16</sub>	30.2	3 <sup>1</sup> / <sub>4</sub>	1.5	22	10.4
GVS18A-05S-9	4,500	1.80	1.30	Side	5/8"-11	6	15.2	2 <sup>1</sup> / <sub>8</sub>	53.9	7 <sup>1</sup> / <sub>8</sub>	3.2	50	23.6
GVS20A-06S-7	6,000	2.00	1.50	Side	5/8"-11	6	15.2	2 <sup>1</sup> / <sub>8</sub>	53.9	7 <sup>1</sup> / <sub>8</sub>	3.2	61	28.8

Air Inlet: 1/4" NPT (GV08A models) 1/2" NPT (GVS models) 3/8" NPT (GVG models)

Recommended Hose Size: 3/16" (GV08A models) 3/4" (GVS models) 1/2" (GVG models)

Performance Figures are at 90 PSI air pressure

G-7 = 7" Guard; G-9 = 9" Guard; F-6 = 6" Guard; P-7 = 7" Polishing Bonnet; S-7 = 7" Back-Up Pad; S-9 = 9" Back-Up Pad

## Heavy Duty Grinder Accessories

Description	Series GV08 Part No.	Series GRS/GRP/GVS Part No.	Series GRG/GVG Part No.
5" Sanding Pad Assembly (medium)	77A-AM825-5	77A-AM825-5	—
7" Sanding Pad Assembly (medium)	77A-AM825-7	77A-AM825-7	—
7" Sanding Pad Assembly (firm)	77A-AM825-7	477A-AM825-7	—
9" Sanding Pad Assembly (firm)	77A-AM825-9	77A-AM825-9	—
7" Wool Polishing Bonnet	P500-850	P500-850	—
Pad Mounting Kit	77A-826	77A-826	—
Pad Nut Wrench	AG230-26M	AG230-26M	—
Spindle Wrench	7S60-24818	7S60-24818	—
7" & 9" Type 27 Wheel Adapter Kit <sup>1</sup>	—	—	R3F-AS337
6" Type 6 or 11 Cup Wheel Guard	—	—	88V60-A216
Piped-Away Exhaust Kit	—	—	88V60-K184
Wheel Retaining Screw Wrench	—	88V-562	88V-562

(1) For use with Type 27 "Plain Hole" Depressed Center.



Toll-Free 1-866-763-6226 Phone: 905-672-5557  
Fax: 905-672-5559 Email: sales@dobcoeqp.com

# Classic Line Die Grinders

## Finishing Tools

**Rated Power: 20,000 to 85,000 rpm / 0.1 hp (.08 kW)**

### Standard Equipment

- Collet with Insert
- Collet Wrenches
- 6'-long x 7/32" ID (1.8 m x 6 mm) Air Hose and 18"-long Exhaust Overhose on Models GH011A-600-(-).
- 7'-long x 3/16" ID (2.1 m x 4.8 mm) Air Hose on Models 7978-(-), 7980-(-), and 7114-E.
- 39830 Cartridge Air Filter on Models 7980-(-) and 7114-E.

### Turbine Grinders

**85,000 RPM / .1 hp (.08 kW)**

**Capacity: 1/8" Carbide Bur 3/8" Mounted Stone**

- Ideal high-speed tools for final cleaning / polishing of dies.

### Pencil Grinders

**60,000 RPM / .1 hp (.08 kW)**

**Capacity: 1/4" Carbide Bur Grinder 1/4" Mounted Stone**

- Excellent for intricate grinding applications, including mold finishing, deburring, cleaning and polishing.
- Trim, comfortable design enables excellent control.
- Choice of rear exhaust or front exhaust models.

### Die Grinders

**20,000 RPM / .1 hp (.08 kW)**

**Capacity: 1/4" Carbide Bur 1/2" Mounted Stone**

- Ideal for mold finishing, light deburring and flash removal.

**CLASSIC™**  
LINE



### Classic Line Die Grinders

Model No.	Free Speed rpm	Throttle Style	Std Collet Size in. mm	Exhaust Location	Spindle Thread Male	Spindle Offset in. mm	Tool Length in. mm	Tool Weight oz. kg	@ Free Speed Air Cons. cfm L/s	Sound Level dB(A)	Std Collet Insert Part No.
7980-2	85,000	Lever	1/8 3	Front	N/A	.6 14	5.6 143	14 .40	9 4.3	84	31812-4
• 7980-A	85,000	Twist	1/8 3	Front	N/A	.6 14	5.6 143	14 .40	9 4.3	84	31812-4
• 7978	60,000	Slide	1/8 —	Front	N/A	.4 9	5.6 143	5.5 .15	6 2.8	80	46119-2
• GH011A-600-1	60,000	Twist	1/8 —	Rear	N/A	.34 9	5.3 136	2.6 .07	7 3.3	77	47568-1
• 7114-E	20,000	Lever	1/8 3	Front	N/A	.5 12	6 152	13 .37	6 2.8	79	31812-4

• Most popular model Hose Inlet – 1/8" NPTF Recommended Air Pressure – 90 PSI (6.2 bar)

### Optional Collet Inserts

For Models	Part No.	Description
7980 & 7114-E	31812-(-)	Collet Insert
7978	46119-(-)	Collet Insert
GH011A	47568-(-)	Collet Insert

For other optional collet inserts see page 93.



Part No. 39830  
Cartridge Air Filter

# Classic Line Die Grinders Finishing Tools

**Rated Power: 20,000 rpm / 0.6 hp (.45 kW)**



8827-ARO  
with 45248-1 Universal Guide



8827-ARO  
with 45248-2 Guide

## Stylus Router

20,000 rpm / .6 hp (.45 kW)

Capacity: 1/4" Collet

2 1/2" Carbide Bit

- Powerful, lightweight router for use with templates on laminated plastics, FRP and FMC materials, wood and sheet metal.
- Choice of guide assemblies at extra cost. Order tool with desired guide number.

## Classic Line Die Grinders

Model No.	Free Speed rpm	Throttle Style	Std Collet Size		Exhaust Location	Tool Length		Tool Weight		@ Free Speed		Std Collet Insert Part No.	
			in.	mm		in.	mm	oz	kg	Air Cons. cfm	Sound Level L/s dB(A)		
8827-ARO	20,000	Lever	1/4	6	Rear	9.1	231	1.4	.7	31	1	84	33226-8

Air Inlet – 1/4" NPTF

Recommended Air Pressure – 90 PSI (6.2 bar)

Recommended Hose Size – 5/16" (8 mm) I.D.

## Standard Equipment

- Collet
- Collet Wrenches

## Extra Cost Accessories

Part #	Description
45248-1	Universal Guide Assembly
45248-2	Guide Assembly
45253-()	Pipe Exhaust Assembly

## 45248-1 Universal Guide Assembly

Recommended for maximum bit exposure.

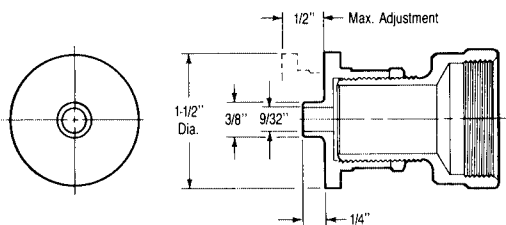

## 39980-() Router Guides for 1/4" Bits

Guides thread into 1/2-20 (female) thread on Guide.

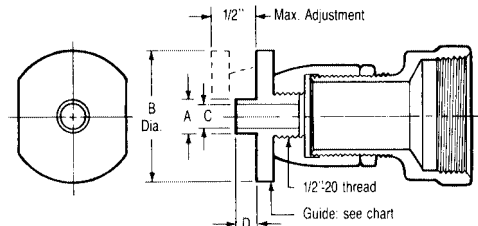

## Dimensions

Guide Part No.	A		B		C		D	
	in.	mm	in.	mm	in.	mm	in.	mm
39980-3	3/8	10	3/4	19	9/32	7	1/4	6
39980-5	3/8	10	1 1/2	38	9/32	7	1/8	3
39980-6	3/8	10	1 1/2	38	9/32	7	1/4	6
39980-7	3/8	10	1 1/2	38	9/32	7	3/8	10
39980-8	3/8	10	2 1/2	64	9/32	7	3/8	10
39980-11	7/16	11	3/4	19	21/64	8	3/8	10
39980-14	7/16	11	1 1/2	38	21/64	8	3/8	10
39980-16	1/2	13	1 1/2	38	21/64	8	1/4	6
39980-18	1/2	13	1 1/2	38	21/64	8	1/2	13
39980-19	1/2	13	2 1/2	64	21/64	8	1/2	13

## 45248-2 Guide Assembly

Recommended for template routing. Also order 39980-() Router Guide, separately. 39980-6 guide is furnished as standard unless otherwise specified.

# Classic Line Die Grinders

## Finishing Tools

**Rated Power: 14,500 to 30,000 rpm / 0.3 to .6 hp (0.2 to 0.4 kW)**

### Standard Equipment

- Collet with Insert

### Die Grinders

**30,000 RPM / .3 hp (.2 kW)**

**Capacity: 5/8" Carbide Bur 1" Mounted Stone**

- Popular, lightweight tools for light deburring and flash removal.
- Optional lock-off throttle lever shown.

**CLASSIC™**  
LINE



8475-A

### Classic Line Die Grinders

Model No.	Free Speed rpm	Throttle Style	Std Collet Size in. mm <sup>1</sup>	Exhaust Location	Spindle Thread Male	Spindle Offset in. mm	Tool Length in. mm	Tool Weight oz. kg	@ Free Speed Air Consp. cfm L/s	Sound Level dB(A)	Std Collet Insert Part No.
8475-A	30,000	Lever	1/4 -	Front	5/16-24	.7 17	5.1 132	12 .34	18 8.5	81	41750-3
8475-A1	30,000	Lever	1/4 -	Front	5/16-24	.7 17	5.1 132	12 .34	18 8.5	81	31812-8

- Most popular models

Note:-A1 models are equipped with a 44124-8 Erickson Collet. For metric size collets, order tool "with" 41753-().

For metric size collet inserts, see 41750-() on page 93.

Air Inlet – 1/4" NPTF Recommended Air Pressure – 90 PSI (6.2 bar) Recommended Hose Size – 5/16" (8 mm) I.D.

### Option Collet Inserts

For Models	Part No.	Description	Substituted for Standard
All -A	41750-()	Collet Insert	Collet Insert
All -A1	31812-()	Erickson Collet	Collet Insert
8475	45953	Lock-off lever	Lever (Extra Cost Accessory)

For other optional collet inserts see page 93.

### Standard Equipment

- Collet with Insert
- Collet Wrenches

### Die Grinders

**21,000 RPM / .5 hp (.4 kW)**

**Capacity: 1 1/2" Mounted Stone**

- Very popular, all-purpose die grinders for deburring and flash removal.
- Optional lock-off throttle lever shown.

**18,000 RPM / .4 hp (.3 kW)**

**Capacity: 1 1/2" Mounted Stone 2" x 1/2" Type 1 Wheel**

- Excellent deburring and flash removal tool.
- Optional lock-off throttle lever shown

**14,500 to 18,000 rpm / .6 HP (.4 kW)**

**Capacity: 1 1/2" Mounted Stone 2" x 1/2" Type 1 Wheel**

- Designed for heavier stock removal and deburring applications in foundries and metal fab shops.
- Built-in speed regulator.
- Optional lock-off throttle lever shown.



7153-C



8212-1B



7015-11

### Classic Line Die Grinders

Model No.	Free Speed rpm	Throttle Style	Std Collet Size in. mm <sup>1</sup>	Exhaust Location	Spindle Thread Male	Spindle Offset in. mm	Tool Length in. mm	Tool Weight oz. kg	@ Free Speed Air Consp. cfm L/s	Sound Level dB(A)	Std Collet Insert Part No.
8212-1B <sup>1</sup>	21,000	Lever	1/4 -	Front	3/8-24	.8 21	5.9 149	1.4 .6	27 12.7	86	41750-3
7015-11 <sup>1</sup>	18,000	Lever	1/4 -	Front	3/8-24	.8 21	5.9 149	1.2 .5	22 10.4	84	37431-3
7149-C	18,000	Button	1/4 -	Side	3/8-24	.9 24	7.0 179	2.0 .9	21 9.9	86	41750-3
7153-C <sup>1</sup>	18,000	Lever	1/4 -	Side	3/8-24	.9 24	7.0 179	2.0 .9	21 9.9	86	41750-3
7236-C	14,500	Lever	1/4 -	Side	3/8-24	.9 24	7.0 179	2.0 .9	23 10.9	83	41750-3

- Most popular models

(1) For other optional collet inserts see page 93.

Air Inlet – 1/4" NPTF Recommended Air Pressure – 90 PSI (6.2 bar) Recommended Hose Size – 5/16" (8 mm) I.D.



# Classic Line Die Grinders Finishing Tools

Rated Power: 12,000 to 18,000 rpm / (0.3 to 0.6 kW)

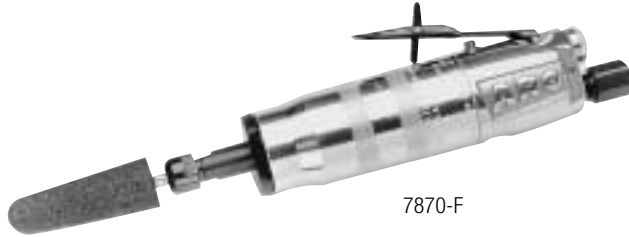

### Standard Equipment

- Collet with Insert
- Collet Wrenches

### Die Grinders

18,000 rpm & 12,000 RPM

0.8 hp (.6 kW) & .4 hp (.3 kW)

Capacity: 2" Mounted Stone 2" Type 1 Wheel

- Excellent tools for removal of parting lines on castings and heavier deburring applications.
- Duplex bearings provide added spindle support for longer life.
- Built-in speed regulator.
- Optional lock-off throttle lever shown.

17,000 rpm / .5 HP (.4 kW)

Capacity: 1 1/2" Mounted Stone 2" Type 1 Wheel

- Popular tools for heavier flash removal and deburring.
- Built-in regulator.
- Optional lock-off throttle lever shown.

### Classic Line Die Grinders

Model No.	Free Speed rpm	Throttle Style	Std Collet Size		Exhaust Location	Spindle Thread Male	Spindle Offset in. mm	Tool Length		Tool Weight		@ Free Speed		Std Collet Insert Part No.	
			in.	mm <sup>1</sup>				in.	mm	lbs	kg	Air Consp. cfm	Sound Level L/s dB(A)		
• 7870-F	18,000	Lever	1/4	-	Rear	3/8-24	.9 24	7.8	198	2.4	1.1	30	14.2	87	41750-3
7872-F	18,000	Button	1/4	-	Rear	3/8-24	.9 24	7.8	198	2.4	1.1	30	14.2	87	41750-3
• 7015-E	17,000	Lever	1/4	-	Rear	3/8-24	.9 22	6.6	168	1.6	.7	24	11.3	84	41750-3
7014-E	17,000	Button	1/4	-	Rear	3/8-24	.9 22	6.6	168	1.6	.7	24	11.3	84	41750-3
7871-F	12,000	Lever	1/4	-	Rear	3/8-24	.9 24	7.8	198	2.4	1.1	15	7.1	81	41750-3

- Most popular models

(1) For metric size collet inserts, see 41750-(-) on page 93.

Air Inlet – 1/4" NPTF Recommended Air Pressure – 90 PSI (6.2 bar) Recommended Hose Size – 5/16" (8 mm) I.D.

### Optional Collet Inserts

For Models	Part No.	Description	Substituted for Standard
All	41750-(-)	Collet Insert	Collet Insert
All	41127-(-)	Erickson Collet	Collet

For other optional collet inserts see page 93.

### Extra Cost Accessories

For Models	Part No.	Description
7014, 7015	44360-(-)	Piped Exhaust Assembly
All Lever Models	45779	Lock-Off Lever

For Piped Exhaust Assembly see page 110.

For Lock-Off Lever see page 93.

# Classic Line Extension Grinders

## Finishing Tools

**Rated Power: 4,500 rpm / 0.7 hp (0.5 kW)**

### Standard Equipment

- Arbor Adapter on Wire Brush Tools
- Collet and Insert on Rotary File Tools
- Collet or Adaptor Wrenches
- Flanges and Nuts

### Wire Brush Tools

**4,500 RPM / .7 hp (.5 kW)**

- Excellent tools for fast surface cleaning for weld and paint preparation.
- Optional lock-off throttle lever shown.

### Rotary File Tools

**4,500 RPM / .7 hp (.5 kW)**

- Designed for heavier deburring in metal fab shops.
- Built-in speed regulator.
- Optional lock-off throttle lever shown.

**CLASSIC™**  
LINE



8067-E1



7874-E2

### Classic Line Extension Grinders

Model No.	Free Speed rpm	Throttle Style	Std Arbor/ Collet Size in. mm <sup>1</sup>	Exhaust Location	Spindle Thread Male	Spindle Offset in. mm	Tool Length in. mm	Tool Weight lbs kg	@ Free Speed Air Cons. cfm L/s	Sound Level dB(A)	Std Arbor Adpt Collet Insert Part No.
<b>Wire Bush Tools</b>											
8067-E1	4,500	Lever	3/8 -	Rear	3/8-24	.9 24	12.9 329	3.7 1.7	32 15.1	88	36934
7874-E1	4,500	Lever	3/8 -	Rear	3/8-24	.9 24	10.1 257	3.0 1.4	32 15.1	88	36934
<b>Rotary File Tools</b>											
8067-E2	4,500	Lever	1/4 -	Rear	3/8-24	.9 24	12.9 329	3.7 1.7	32 15.1	88	41750-3
7874-E2	4,500	Lever	1/4 -	Rear	3/8-24	.9 24	10.1 257	3.0 1.4	32 15.1	88	41750-3

(1) For metric size collet inserts, see 41750-( ) on page 93.

Air Inlet – 1/4" NPTF Recommended Air Pressure – 90 PSI (6.2 bar) Recommended Hose Size – 5/16" (8 mm) I.D.

### Optional Collet Inserts

For Models	Part No.	Description	Substituted for Standard
All	41750-( )	Collet Insert	Collet Insert
All	33226-( )	Erickson Collet	Collet
All	45779	Lock-Off Lever <sup>1</sup>	Lever

(1) Extra cost accessory.

For other optional collet inserts see page 93.

Classic Line Right-Angle Grinders  
**Finishing Tools**

Rated Power: 13,000 to 14,000 rpm / 0.5 hp (0.4 kW)

**Right Angle-Grinders**

13,000 & 14,000 rpm / .5 HP (.4 kW)

Capacity: 1/4" x 4" Type 27 and 28 Wheel

1" Mounted Stone

3" Sanding Pad

- Excellent general purpose grinders.
- Designed for tough, hard-to-reach applications in foundries, shipyards, metal fab shops, power plants and general plant maintenance.



8318

**Classic Line Right-Angle Grinders**

Model No.	Free Speed rpm	Throttle Style	Wheel Cap. Dia. in. mm	Wheel Type	Exhaust Location	Spindle Thread Male	Tool Length in. mm	Angle Head Height in. mm	Tool Weight lbs kg	@ Free Speed Air Consp. cfm L/s	Sound Level dB(A)	Std Collet Insert Part No.
8318	13,000	Lever	4 102	27 & 28	Rear	3/8-24	9.1 232	2.4 62	2.7 1.2	25 11.8	84	45977
8317-L-1	14,000	Lever	4 102	Cut-off	Rear	3/8-24	9.1 232	2.6 67	2.7 1.2	25 11.8	84	45207
8317-L-2	14,000	Lever	3 76	27	Rear	3/8-24	9.1 232	2.4 62	2.7 1.2	25 11.8	84	45558
8317-L-4	14,000	Lever	1 25	Mt Stone	Rear	1/4" collet	9.1 232	2.8 70	2.7 1.2	25 11.8	84	41750-3
			3 76	Sanding Pad								

- Most popular model

Air Inlet – 1/4" NPTF Recommended Air Pressure – 90 PSI (6.2 bar) Recommended Hose Size – 5/16" (8 mm) I.D.

**Optional Collet Inserts**

For Models	Part No.	Description	Substituted for Standard
8317 & 8318	45779	Lock-Off Lever <sup>1</sup>	Lever
8317-L-4	41750-(-)	Collet Insert	Collet insert

(1) Extra cost accessory.  
 For other optional collet inserts see page 93.

**Extra Cost Accessories**

For Models	Part No.	Description
8317 & 8318	48932	Dead Handle
8317 & 8318	44360-(-)	Piped Exhaust Assembly

For Piped Exhaust Assembly see page 110.

# Classic Line Right-Angle Grinders and Sanders

## Finishing Tools

**Rated Power: 12,000 to 20,000 rpm / 0.3 hp (0.2 kW)**

### Standard Equipment

- Collet on Models 7581-F & 8479-(-).

### Right Angle-Sander

14,000 RPM / .3 hp (.2 kW)

Capacity: 3" Sanding Pad

- Excellent tool for contour sanding and for finishing in limited access areas.
- Optional lock-off throttle lever shown.

### Right-Angle Grinders / Sanders

12,000 & 20,000 rpm / .3 HP (.2 kW)

Capacity: A, B, and W Shapes 3" Sanding Pad

- Ideal for finishing hard-to-reach areas, such as tight corners, irregular contours and small orifices.
- Can be used to finish metal, fiberglass and wood.
- One-piece angle housing provides high durability.
- Optional lock-off throttle lever shown.

**CLASSIC™**  
LINE

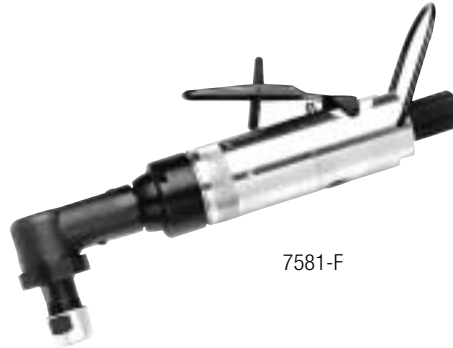

7581-F

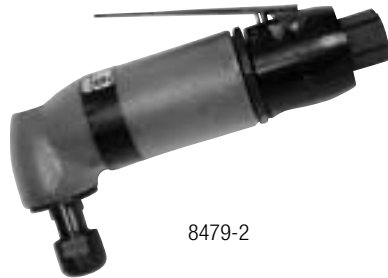

8479-2



8480-1  
(Pad not included)

### Classic Line Right-Angle Grinders and Sanders

Model No.	Free Speed rpm	Throttle Style	Collet Size in.	Exhaust Location	Spindle Thread Male	Tool Length in. mm	Angle Head Height in. mm	Tool Weight lbs kg	@ Free Speed Air Cons. cfm L/s	Sound Level dB(A)	Standard Collet Insert Part No.
• 7581-F	14,000	Lever	1/4	Rear	-	8.2 210	2.3 58	2.0 .9	17 8	81	37431-3
• 8479-1	12,000	Lever	1/4	Rear	-	5.8 149	2.9 73	1.2 .7	14 6.6	84	41750-3
• 8479-2	20,000	Lever	1/4	Rear	-	5.8 149	2.9 73	1.2 .7	17 8	84	41750-3
• 8480-	12,000	Lever	1/4	Rear	1/4-20	5.8 149	2.9 73	1.2 .7	14 6.6	84	-
• 8480-2	20,000	Lever	1/4	Rear	1/4-20	5.8 149	2.9 73	1.2 .7	17 8	84	-

- Most popular models

Air Inlet – 1/4" NPTF Recommended Air Pressure – 90 PSI (6.2 bar) Recommended Hose Size – 5/16" (8 mm) I.D.

### Optional Collet Inserts

For Models	Part No.	Description	Substituted for Standard
7581-F	37431-(-)	Rubber Flex Collet Insert	Collet Insert
8479	41750-(-)	Collet Insert	Collet Insert
All	45953	Lock-Off Lever <sup>1</sup>	Lever

- (1) Extra cost accessory.  
For other optional collet inserts see page 93.

### Extra Cost Accessories

For Models	Part No.	Description
All	44648	2" Sanding Back-Up Pad <sup>1</sup>
All	44647	3" Sanding Back-Up Pad <sup>1</sup>
8479, 8480	45369-4	Piped Exhaust Assembly

- (1) Back-up pads will adapt to either a 1/4" collet or 1/4-20 UNC-male spindle.  
Pads accept fast locking type sanding discs. See page 88.  
For Piped Exhaust Assembly see page 110.

# Classic Line Right-Angle Sanders and Polishers

## Finishing Tools

Rated Power: 15,00 to 6,000 rpm / 0.5 to 0.9 hp (0.4 to 0.7 kW)



### Standard Equipment

- 7" Sanding Back-Up Pad and Nut (except Model 7945-EW).
- Pad Wrenches (except Model 7945-EW).
- Model 7945-EW equipped with Watter Nozzle and Rubber Shield for wet sanding applications.

### Right-Angle Sanders

1,500 to 6,000 rpm / .5 to .9 hp (0.4 to 0.7 kW)  
Capacity: 7" Sanding Pad

- Excellent, lightweight metal prep tools for weld blending and finish rework applications.

### Right-Angle Polishers

1,500 to 6,000 rpm / .5 to .9 hp (0.4 to 0.7 kW)  
Capacity: 7" Bonnet

- Ideal for putting final sheen on fiberglass, stainless steel, painted surfaces and furniture.

### Classic Line Right-Angle Sanders and Polishers

Model No.	Free Speed rpm	Throttle Style	Collet Size in. mm	Exhaust Location	Spindle Thread Male	Tool Length in. mm	Angle Head Height in. mm	Tool Weight lbs kg	@ Free Speed Air Cons. cfm L/s	Sound Level dB(A)	Standard Back-Up Part No.
<b>Sanders</b>											
7096-D	3,500	Lever	7 178	Side	5/8-11	9.5 241	4.5 114	4.3 1.9	22 10.4	86	45361
7945-E	1,500	Lever	7 178	Rear	5/8-11	10.9 277	4.5 114	4.4 2.0	32 15.1	87	45361
7945-EW	1,500	Lever	7 178	Rear	5/8-11	15.0 381	4.5 114	6.5 2.9	32 15.1	87	None
7944-E	3,500	Lever	7 178	Rear	5/8-11	10.9 277	4.5 114	4.4 2.0	32 15.1	87	45361
7939-E	6,000	Lever	7 178	Rear	5/8-11	10.9 277	4.5 114	4.4 2.0	32 15.1	87	45361
<b>Polishers</b>											
7098-D <sup>1</sup>	1,500	Lever	7 178	Side	5/8-11	9.5 241	4.5 114	4.3 1.9	22 10.4	86	45361
7945-E <sup>1</sup>	1,500	Lever	7 178	Rear	5/8-11	10.9 277	4.5 114	4.4 2.0	32 15.1	87	45361

(1) Lamb's Wool Bonnet must be ordered separately.

Air Inlet – 1/4" NPTF Recommended Air Pressure – 90 PSI (6.2 bar) Recommended Hose Size – 5/16" (8 mm) I.D.

### Accessories

For Models	Part No.	Description	Substituted for Standard
All <sup>1</sup>	31859-()	Back-Up Pad & Nut	Back-Up Pad
All <sup>1</sup>	32809-()	Back-Up Pad & Nut	Back-Up Pad
7939, 7944 & 7945	45779	Lock-Off Lever <sup>2</sup>	Lever

(1) Except Model 7945-EW.

(2) Extra Cost.

For Piped Exhaust Assembly see page 110.



# Finishing Tools

To maintain production and safety levels, ARO offers a full line of finishing tool accessories including replacement sanding pads, wheel guards, and adapter kits.

### Additional Accessories

For information on the complete line of ARO Finishing Tool Accessories, refer to the IRAX Accessory Catalog.



### Wheel Guards

Guard Part No.	Wheel Dia.		Clamp Dia.	
	in.	mm	in.	mm
<b>Type 1 Wheels</b>				
44451	2	51	15/16	33
37037-2	2	51	19/16	40
37900	2	51	1 11/16	43
44450	2 1/2	64	15/16	34



### Wheel Arbors



Arbor Part No.	Drive Spindle Female	Arbor Diameter		Maximum Wheel Width	
		in.	mm	in.	mm
40818	5/16-24	3/8	10	3/8	10
36934	3/8-24	3/8	10	3/8	10

### Sanding Back-Up Pads for 5/8-11 (Male) Spindle

Diameter	in.	mm	Medium		Rigid	
			Part No.	Part No.		
5		127	77A-AM825-5	-		
7		178	77A-AM825-7	77A-BM825-7		
9		229	-	77A-AM825-9		
Pad Mounting Kit			77A-826	77A-826		

### R3F-AS337 Type 27 Wheel Adapter Kit

Contains all components for adapting a 7" and 9" diameter Type 27 wheel to vertical grinders with a 5/8-11 male spindle.



### Collet Inserts

Capacity	in.	mm	Collet Insert Part no.	
			Part no.	Part no.
1/8		-	46119-2	
-		3	46119-3	
3/32		-	46119-1	
1/8		-	47568-1	
-		3	47568-2	
3/32		-	47568-3	

### Extension Collet for 3/8-24 (Female) Spindles

Extension Part No.	Length		Output Spindle
	in.	mm	
30385-1	6	153	1/4" Collet



## Accessories

# Finishing Tools



41753-1



41753-3



30489-2

### Three Piece Collets

Capacity in. / mm	Collet for <sup>3</sup> / <sub>8</sub> -24 Male Spindle	Collet for <sup>5</sup> / <sub>16</sub> -24 Male Spindle	Collet Insert Part No.
<sup>1</sup> / <sub>8</sub> "	41753-1	41755-1	41750-1
<sup>3</sup> / <sub>16</sub> "	41754-2	41755-2	41750-2
<sup>1</sup> / <sub>4</sub> "	41753-3	41755-3	41750-3
3 mm	41753-11	41755-11	41750-11
6 mm	41753-12	41755-12	41750-12

Collet Insert included when Collet is ordered.

### Two Piece Collets

Capacity in.	Collet for <sup>3</sup> / <sub>8</sub> -24 Male Spindle
<sup>1</sup> / <sub>8</sub> "	30489-2
<sup>1</sup> / <sub>4</sub> "	30489-1
<sup>3</sup> / <sub>8</sub> "	32966-1
<sup>1</sup> / <sub>2</sub> "	32966-2

### Erickson Three Piece Collets

Capacity Range in. to in. mm	Collet for <sup>5</sup> / <sub>16</sub> -24 Male Spindle	Collet for <sup>3</sup> / <sub>8</sub> -24 Male Spindle	Collet Insert Part No.	Collet for <sup>3</sup> / <sub>8</sub> Male Spindle	Collet Insert Part No.
<sup>1</sup> / <sub>64</sub> to <sup>3</sup> / <sub>64</sub>	44124-1	33226-1	31812-1	-	-
<sup>3</sup> / <sub>64</sub> to <sup>5</sup> / <sub>64</sub>	44124-2	33226-2	31812-2	-	-
<sup>5</sup> / <sub>64</sub> to <sup>3</sup> / <sub>32</sub>	44124-3	33226-3	31812-3	-	-
<sup>3</sup> / <sub>32</sub> to <sup>1</sup> / <sub>8</sub>	44124-4	33226-4	31812-4	44127-1	32968-1
<sup>1</sup> / <sub>8</sub> to <sup>5</sup> / <sub>32</sub>	44124-5	33226-5	31812-5	44127-2	32968-2
<sup>5</sup> / <sub>32</sub> to <sup>3</sup> / <sub>16</sub>	44124-6	33226-6	31812-6	44127-3	32968-3
<sup>3</sup> / <sub>16</sub> to <sup>7</sup> / <sub>32</sub>	44124-7	33226-7	31812-7	44127-4	32968-4
<sup>7</sup> / <sub>32</sub> to <sup>1</sup> / <sub>4</sub>	44124-8	33226-8	31812-8	44127-5	32968-5
<sup>1</sup> / <sub>4</sub> to <sup>9</sup> / <sub>32</sub>	-	-	-	44127-6	32968-6
<sup>9</sup> / <sub>32</sub> to <sup>5</sup> / <sub>16</sub>	-	-	-	44127-7	32968-7
<sup>5</sup> / <sub>16</sub> to <sup>11</sup> / <sub>32</sub>	-	-	-	44127-8	32968-8
<sup>11</sup> / <sub>32</sub> to <sup>3</sup> / <sub>8</sub>	-	-	-	44127-9	32968-9

Collet Insert included when Collet is ordered.



33226-3



44127

### Jacobs Collets with Rubber Flex Inserts

in. to in.	Capacity Range in. to in. mm to mm	Collet Part No.	Collet Insert Part No.
<sup>3</sup> / <sub>32</sub> to <sup>3</sup> / <sub>16</sub>	.094 - .198 2 to 4	39959-2	37431-2
<sup>3</sup> / <sub>16</sub> to <sup>1</sup> / <sub>4</sub>	.198 - .250 4 to 6	39959-3	37431-3

### Lock-Off Levers

Tool Models	Type of Tool	LeverNo.
8475, 8476, 8477, 8478	Die Grinders	45953
7015-E, 7870-F, 7871-F	Die Grinders	45779
7015-11, 8212-1B	Die Grinders	47052
7840, 7843, 7940, 7943	Extension Grinders	45779
7874, 7875, 8067	Extension Grinders	45779
8317, 8318	Rt.-Angle Grinder	45779
8479, 8480	Rt.-Angle Grinder	45953
7939, 7944, 7945	Production Sanders	45779



47052

## Special Purpose Tools



ARO has built a reputation on customer-oriented problem solving. A big factor is the continuing commitment to meet unique customer needs with Special Purpose Tools.

Special Purpose Tools are regular production models that fill applications outside of assembly and finishing roles. For example, the popular MARXAL™ marking pen can be used to scribe glass for cutting or to mark welds and other surfaces for identification. ARO electrode dressers extend the life and improve the performance of welding equipment. They eliminate the need to remove and recondition or replace electrodes by dressing them in position, in seconds. Once dressed, the electrode is restored to the proper shape for producing uniform, high quality results with reduced energy consumption. ARO offers the most complete line of electrode dressers, cutters, holders, and adapters in the industry. ARO also offers chisel and needle scaling hammers for removing weld flux, rust, or heavier material.

When unusual applications create the need for tailor-made solutions, ARO responds as well . . . through the Custom Tools department. ARO Custom Tools are modified versions of standard products that meet highly specialized assembly or finishing requirements. Some examples include laminate trimmers, short or small diameter pad orbital/random orbital sanders, extended buffing tools. Your ARO distributor or representative can provide more details on Custom Tools capabilities and existing designs.

After the Special Purpose Tools section, you'll find information on ARO general accessories, such as the exclusive Air Transfer Bail, service kits, grips and flanges, and more. Warranty information follows, along with a quick reference index for all tools covered in this catalog, and ARO Tool Products contact information.

<b>Marxal Marking Pen</b> .....	Pg. 88
A comfortable, easy to use tool for making products and tooling for identification.	
<b>Peening and Scaling Hammer</b> .....	Pg. 88
With Alloy-Steel hammer tip for surface preparation.	
<b>Laminate Trimmer</b> .....	Pg. 88
Excellent tool for fast, accurate trimming of plastic laminates.	
<b>Portable Electrode Dressers</b> .....	Pg. 89
The fast, economical solution to restoring worn electrode tips.	
<b>Industrial Tool General Accessories</b> .....	Pgs. 95 – 100
General accessories and ergonomic enhancements for optimum performance and productivity.	
<b>Warranty Information</b> .....	Pg. 101
Terms and coverage for all products covered in this catalog.	
<b>Index / Quick Reference</b> .....	Pgs. 102 – 103
Complete listing, by model number, of products covered in this catalog.	
<b>Warning Information</b> .....	Pg. 104
Safety precautions for operating finishing tools.	
<b>Contact Information</b> .....	Pg. 105
ARO locations for further information and assistance.	

The ARO MARXAL marking pen can be used on all types of material for fast, convenient identification.





# Marxal Marking Pen Peening & Scaling Hammer

## Special Purpose Tools

### MARXAL™ Marking Pen

- Comfortable, easy-to-use tool for marking products or tooling for identification.
- A popular tool for marking welds for identification.
- Can be used to scribe a line on glass for cutting.
- Choice of fine, medium or coarse marking point.

#### Standard Equipment

- Medium Point
- 6' X 1/8" (1.8m X 3.2mm) Air Hose



8315

### Marxal Marking Pen

Model No.	Throttle Type	Strokes per Minute	Standard Point Type	Exhaust Location	Tool Length in. mm	Tool Weight lbs kg	Air Consup. @ Free Speed cfm L/s	Standard Point Part No.
8315	Twist	36,000	Medium	Front	6.4 163	4.8 .13	1.5 .7	39862-2

- Most Popular Model Hose Inlet – 1/4" NPTM Recommended Air Pressure – 90 PSI (6.2 bar)

#### No Cost Options (Order "with" Options)

For Models	Part No.	Description	Substituted for Standard
8315	39862-1	Fine point	Medium point
8315	39862-3	Coarse point	Medium point

### Peening and Scaling Hammer

Furnished complete as illustrated with:

- 1/4" female N.P.F.T air inlet
- Alloy-Steel hammer tip

#### Peening and Scaling Hammer

Model No.	Throttle Type	Blows per Min.	Head Height	Tool Weight
7002	Button	5,000	2 1/2"	10 1/2 oz

Recommended Hose Size – 5/16"



7002

### Laminate Trimmer

20,000 rpm /0.5 hp (.34 kW)

- Excellent tool for fast, accurate trimming of plastic laminates.
- May be operated in either the vertical or horizontal plane.

#### Standard Equipment

- Collet
- Collet Wrenches

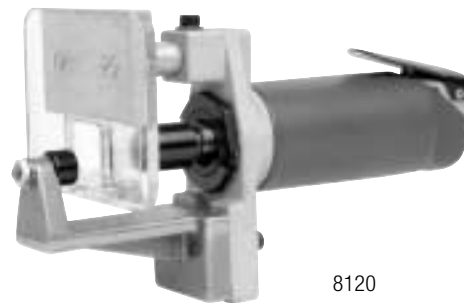

8120

### Laminate Trimmer

Model No.	Free Speed rpm	Throttle Style	Standard Collet Size in. mm	Exhaust Location	Tool Height in. mm	Tool Width in. mm	Tool Weight lbs kg	Air Consup @ Free Speed cfm L/s	Sound Level @ Free Speed dBA	Standard Collet Part No.
8120	20,000	Lever	1/4 6	Front	7.8 198	2.5 64	1.9 .86	27 13	84	33226-8

- Air Inlet – 1/4" NPTF Recommended Air Pressure – 90 PSI (6.2 bar) Recommended Hose Size – 3/8" (10 mm) i.D.

#### No Cost Options (Order "with" Options)

For Models	Part No.	Description	Substituted for Standard
8120	33226-()	Erickson Collet	Erickson Collet



# Portable Electrode Dressers

## Special Purpose Tools

### The Economical Solution to Dressing Worn Electrode Tips.

#### Dressing Electrodes vs. New Tips

Worn electrode tips produce either poor welds or no welds at all, limiting both quality and productivity. Two possible solutions to worn tips are to (1) replace them with new, or (2) recondition existing tips on either a lathe, drill press, or with a portable ARO Electrode Dresser.

Replacing tips is a costly and time consuming alternative. Reconditioning tips on standard machine shop equipment, although providing uniformly dressed electrodes, cuts valuable production time. Reconditioning worn tips with an ARO Electrode Dresser, however, is a convenient, economical solution that minimizes downtime.



7165-B (22 Series)



8040-E (2200 Series)

#### Dressing Electrodes with ARO's Portable Electrode Dresser

Reconditioning with an ARO pneumatic Electrode Dresser is a quick, easy, and accurate method of dressing worn electrodes. Downtime is virtually eliminated because each electrode is automatically dressed in seconds with precision, without removing the tip from the machine.

Once dressed, the electrode has a perfectly shaped tip for producing uniform, quality welds. Furthermore, a properly shaped electrode top reduces energy consumption during the welding process and greatly extends electrode life.

#### ARO Portable Electrode Dressers

ARO offers two models of electrode dressers in several speed options. Both models accept a wide variety of blade and solid-type cutters to accurately dress electrodes from 5/16" to 1 1/2" diameter. They are lightweight and easy to operate, requiring no special training for the operator.

The "22" Series Electrode Dresser is the most popular model and provides adequate power to dress most electrode tips. For larger electrodes where a lot of material must be removed during the dressing operation, the "2200" Series Electrode Dresser is recommended. Three speed options are available in the "2200" Series, with the lower speeds providing more dressing power at a slower material removal rate.

To reduce production downtime, increase electrode tip life, reduce energy consumption, and maintain quality welds, recondition your worn electrode tips with an ARO Portable Electrode Dresser.

#### 22 Series

Model No.	rpm	Electrode Capacity	Air Inlet	Recommended Hose Size	Weight
7165-B	1500	5/16" D to 1 1/2" D	1/4" NPT(F)	5/16" I.D.	3.5 lbs

Extra Cost Options: Cutter blades and adapters. Order separate. See pages 89-92.

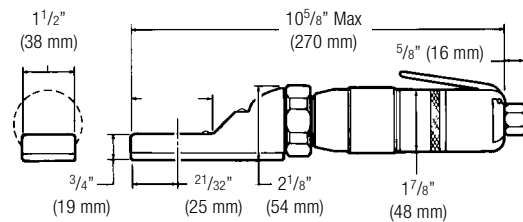

#### 2200 Series

Model No.	rpm	Electrode Capacity	Air Inlet	Recommended Hose Size	Weight
8038-E	250	5/16" D to 1 1/2" D	1/4" NPT(F)	5/16" I.D.	5.5 lbs
8039-E	450	5/16" D to 1 1/2" D	1/4" NPT(F)	5/16" I.D.	5.5 lbs
8040-E	1000	5/16" D to 1 1/2" D	1/4" NPT(F)	5/16" I.D.	4.6 lbs

Extra Cost Options: Cutter blades and adapters. Order separate. See pages 89-92.

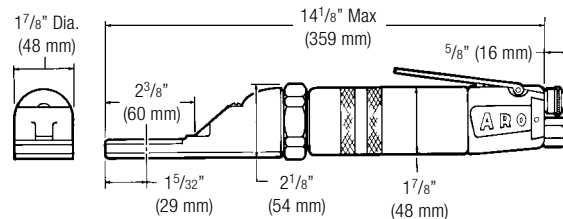

# Portable Electrode Dressers

## Special Purpose Tools

### Electrode Tip Cutters and Cutter Accessories

In addition to portable electrode dressers, ARO also offers a wide selection of both blade and solid-type cutters (pages 89-92), as well as cutter holders, extensions and trimmers (page 92) to accommodate a variety of electrode tips and welding machine set-ups. See the illustration below for the various cutter mounting options.

Both blade and solid cutters are available for flush or extended mounting on ARO Electrode Dressers. Flush style cutters allow access in confined areas, requiring a minimum clearance of only  $\frac{3}{4}$ " between welding faces. Extended style cutters are ideal where the center-to-center distance between electrodes is less than 1", as is the case in many multiple-point and short-stroke stationary welders, but require a minimum clearance of  $1\frac{1}{2}$ " between welding faces. A 1" extension adapter is also available to mount either flush or extended style cutters. For electrodes that have become "mushroomed" with extensive use, preventing a cutter from completely dressing the entire tip, trimmer-type blade holders are available.

### Blade vs. Solid-Type Cutters

Blade-type cutters produce the most accurate reconditioned tip since they are honed to the exact profile of the electrode tip and float in a guide that automatically centers the blade on the electrode. They are more economical than solid cutters in that they are lower priced and easily factory resharpened. Recommended for use on straight electrodes and at higher operating speeds.

Solid-type cutters are of a rugged, one-piece construction, with a series of permanent cutting edges shaped to the electrode tip's contour. Their cutting action is much faster than the blade-type's, thus, minimizing the time of the actual dressing operation. Limitations of the solid cutter, however, include their high cost and the difficulty of resharpening the cutting edges. Recommended for use on tapered electrodes and at lower operating speeds.

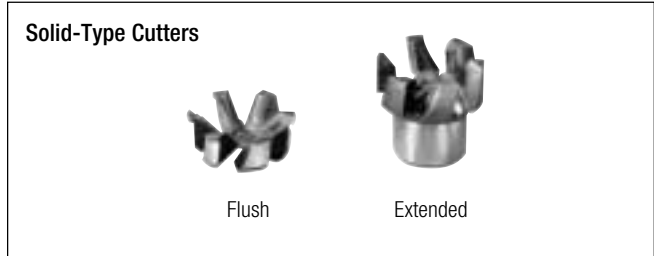
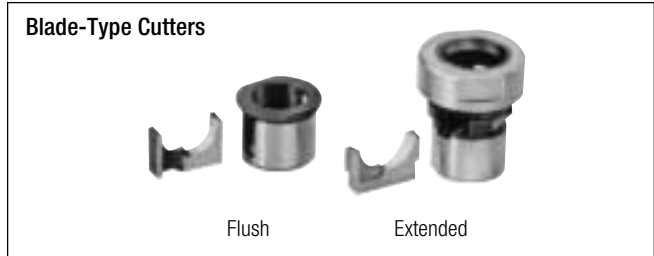

### How To Order Electrode Cutters

To order electrode cutters, locate the diameter electrode to be dressed on pages 89-92, the type of cutter desired (solid or blade), and the electrode tip contour. The electrode tip profiles are drawn to scale, so they can be used as a convenient reference when exact contour measurements are not known. The chart directly below each profile shows the cutter, holder, adapter (where required) to be used for the 22 and 2200 Series Electrode Dressers. Cutter numbers in regular type are flush style; those in italics are extended style. Holders and/or adapters where required must be ordered separately.

Note: Consult factory about cutters for electrode tips not shown here.

### Cutter / Holder / Adapter Arrangements

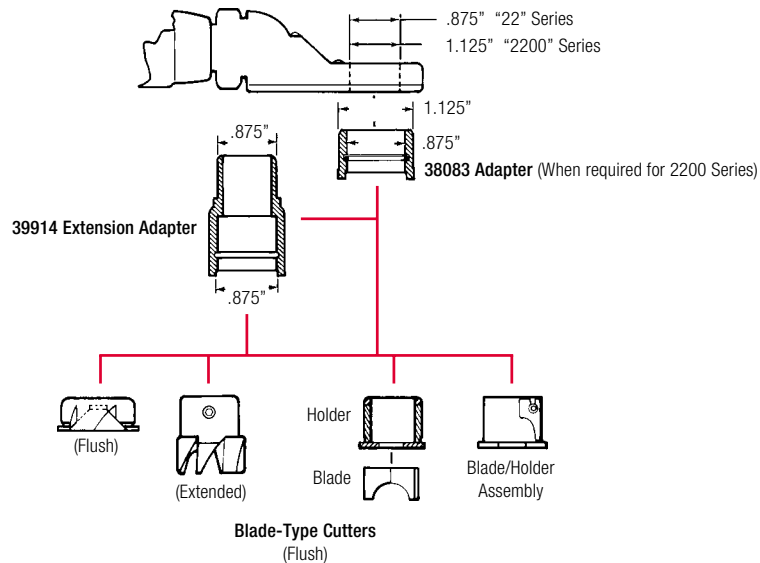

# Portable Electro Dressers

## Special Purpose Tools

### Solid-Type - 0.3625 Dia. (9.2 mm)

Series	Cutter
2200	40856

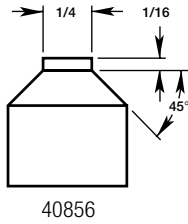

### Solid-Type - 0.437 Dia. (11.1 mm)

Series	Cutter
2200	40856

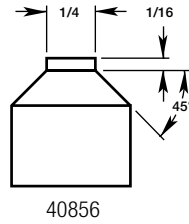

### Solid-Type - 0.460 Dia. (11.7 mm)

Series	Cutter
2200	40856

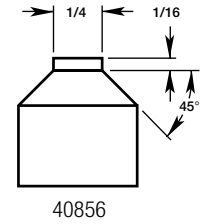

### Solid-Type - 0.482 Dia. (12.2 mm)

Series	Cutter	Adapter	Cutter	Adapter	Cutter	Adapter	Cutter
22	32530	-	32529	-	32528	-	-
2200	32530	38083	32529	38083	32528	38083	40856

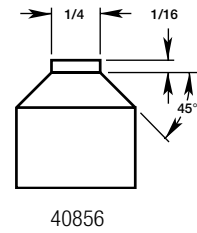
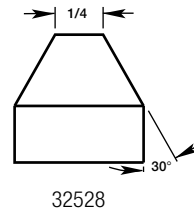
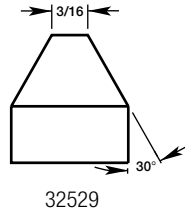
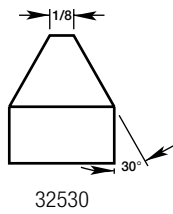

### Blade-Type - 0.482 Dia. (12.2 mm)

Series	Cutter	Adapter	Cutter	Holder	Adapter
22	32509	-	32452	38409	-
2200	32509	38083	32452	38409	38083

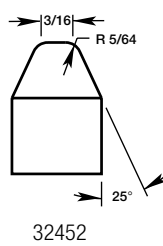
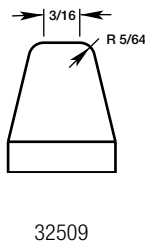

### Blade-Type - 0.482 Dia. (12.2 mm)

Series	Cutter	Adapter
22	38406	-
2200	38406	38083

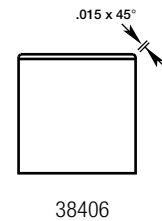

### Solid-Type - 0.490 Dia. (12.4 mm)

Series	Cutter	Adapter	Cutter
22	32528	-	-
2200	32528	38083	40856

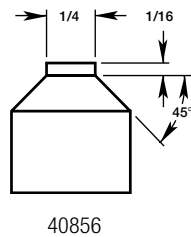
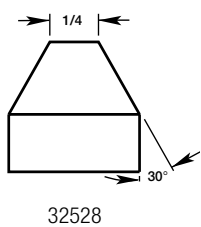

Portable Electro Dressers  
**Special Purpose Tools**

**Solid-Type - 0.500 Dia. (12.7 mm)**

Series	Cutter	Adapter	Cutter	Adapter	Cutter	Adapter	Cutter
22	32530	-	32529	-	32528	-	-
2200	32530	38083	32529	38083	32528	38083	40856

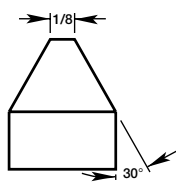

32530

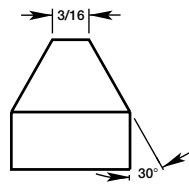

32529

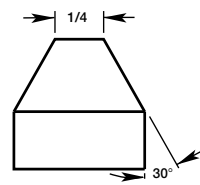

32528

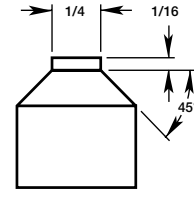

40856

**Blade-Type - 0.500 Dia. (12.7 mm)**

Series	Cutter	Holder	Adapter
22	32283	32288	-
2200	32283	32288	38083

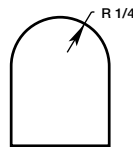

32283

**Solid-Type - 0.588 Dia. (14.9 mm)**

Series	Cutter
2200	40856

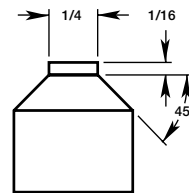

40856

**Solid-Type - 0.625 Dia. (15.9 mm)**

Series	Cutter	Adapter	Cutter	Adapter	Cutter	Adapter
22	40278	-	32530	-	32528	-
2200	40278	38083	32530	38083	32528	38083

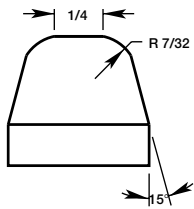

40278

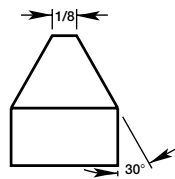

32530

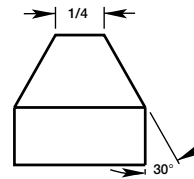

32528

**Solid-Type - 0.625 Dia. (15.9 mm) Continued**

Series	Cutter	Cutter	Cutter	Cutter	Cutter
2200	38417-1	38417-2	40856	38419-2	38171

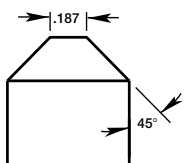

38417-1

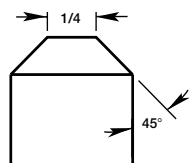

38417-2

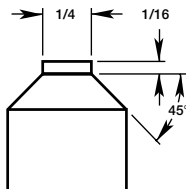

40856

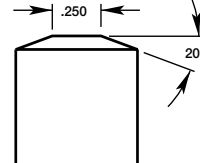

38419-2

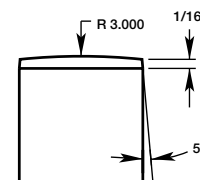

38171

Portable Electrode Dressers  
**Special Purpose Tools**

**Blade-Type - 0.625 Dia. (15.9 mm)**

Series	Cutter	Holder	Adapter	Cutter	Holder	Adapter	Cutter	Holder	Adapter
22	32284	32282-2	-	32455	32282-2	-	-	-	-
2200	32284	32282-2	38083	32455	32282-2	38083	32453	32282-2	38083

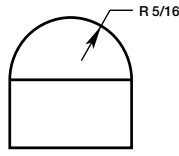

32284

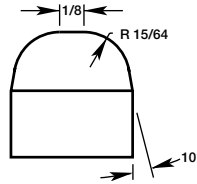

32455

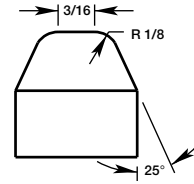

32453

**Blade-Type - 0.625 Dia. (15.9 mm) Continued**

Series	Cutter	Adapter	Cutter	Holder	Adapter
22	32510	-	33090	32282-2	-
2200	32510	38083	33090	32282-2	38083

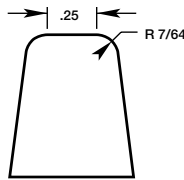

32510

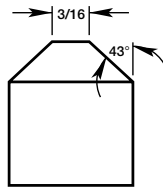

33090

**Blade-Type - 0.625 Dia. (15.9 mm) Continued**

Series	Cutter	Holder	Adapter	Cutter	Holder	Adapter
22	40907	32282-2	-	32491	32282-2	-
2200	40907	32282-2	38083	32491	32282-2	38083

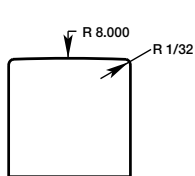

40907

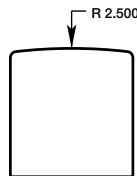

32491

**Blade-Type - 0.625 Dia. (15.9 mm) Continued**

Series	Cutter	Holder	Adapter
22	38408	-	-
2200	32447	32282-2	38083
2200	38408	-	38083

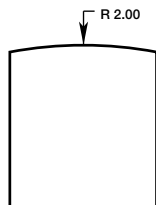

38408  
32447



# Portable Electrode Dressers

## Special Purpose Tools

### Solid-Type - 0.750 Dia. (19.1 mm)

Series	Cutter	Cutter	Cutter
2200	38418-1	40856	38418-2

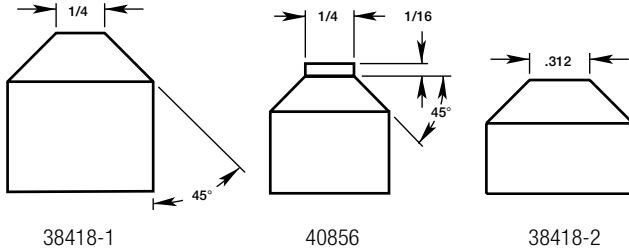

### Solid-Type - 0.875 Dia. (22.2 mm)

Series	Cutter
2200	40856

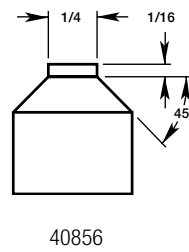

### Flush-Type

For use on both "22" and "2200" Series Electrode Dressers. Requires 38083 adapter for "2200" Series tools.

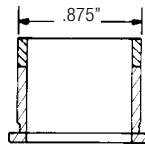

Standard-Type  
Blade Holder

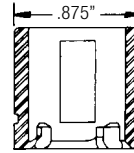

Trimmer-Type  
Blade Holder

Electrode Dia.	Holder No.	Type
0.482	38409	Trimmer
0.500	32288	Standard
0.625	32282-2	Standard

### Adapters

To permit "2200" Series tools, which normally drive 1.125" O.D. cutters and holders, to utilize all .875" O.D. cutters and holders.

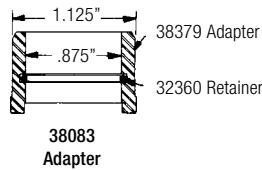

38083  
Adapter

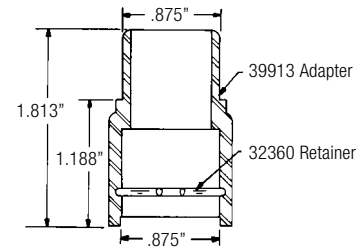

39914 Extension  
Adapter

Use when a .875 O.D. holder or cutter is required in an extended position from the tool. 38083 adapter is required for use on "2200" Series tools.



**Tune-Up / Service kits**

ARO Service Kits are available for the most popular ARO Air Tools and are a convenient, economical way to keep your ARO tools operating at peak performance. Each kit contains all the necessary replacement parts to properly perform preventative maintenance on a particular model tool. All parts are individually wrapped and identified, and packaged in an easy-to-store carton with a service manual, parts list, oil and grease. To order, locate the particular model or series ARO Air tool in the chart and specify the appropriate kit number.

Tool Models / Series	Service Kit
7015-11, 8212-1B, 8213-1B Die Grinder .....	39001
8525-C thru 8527-C Drill and Screwdriver .....	39929
7149-C, 7153-C, 7235-C and 7236-C Die Grinder .....	40102-1
7014-E & 7015-E Die Grinders .....	41800
8506, 8509, 8515 & 8521 w/Adjustable Clutch QRT Screwdrivers .....	42114
8506, 8509, 8515 & 8521 w/Direct Drive QRT Screwdrivers .....	42122-2
8506, 8509, 8515 & 8521 w/Positive Clutch QRT Screwdrivers .....	42341
8318 Right-Angle Grinder .....	44367
8316 Scaling Hammer .....	44694
8317 Right-Angle Grinder .....	45780
Series 20 "B" and "C" Model Screwdrivers .....	46992
Series 20 "C" Model QRT Screwdrivers .....	48817-1
Series 20 Right-Angle Screwdrivers .....	48803-1
Series 20 "B" Model Drills .....	47755
Series 20 Right-Angle Drills .....	48446-1
Series 50 "B" and "C" Model Screwdrivers .....	47353-1
Series 50 "C" Model QRT Screwdriver .....	48818-1
Series 50 Right-Angle Screwdrivers .....	48804-1
Series 50 "B" Model Drills .....	47756
Series 50 Right-Angle Drills .....	48447-1
Series 50 Nutsetters .....	47407
Series 80 Nutsetters .....	47369
8448-A1(), 8448-A3() Orbital Sander .....	48248-1
8446-B(), 8447-D() and 8457-A() Random Orbital Sanders .....	48249-1
8416, 8417 and 8418 Mini Random Orbital Sanders .....	48894
RS2 Elite Sanders (also 8416, 8417, 8418 classic line mini sanders built after 12/1/93) .....	49837
8446-B, 8447-E and 8457-B Random Orbital Sanders produced after 12/1/93 .....	49846

## Industrial Tool Accessories

# Assembly Tools

The ARO Air Transfer Bail (ATB) is a revolutionary way to improve both the ergonomics and productivity of many assembly operations in which pistol grip fastening tools are used. By directing the air supply from the top of the tool instead of underneath through the handle, there's no dangling air hose to get in the way. The ARO ATB also promotes proper tool handling practices. And since it's designed for use with ARO Automatic Shut-off Screwdrivers, your operators benefit from the ergonomically-correct handle designs and minimum exposure to torque reaction to further reduce strain on the wrist.

Available for use on all ARO Series 20 & 50 pistol grip push-to-start auto shut-off screwdrivers only.

- 48994 for all Series 20 Models AG024A-().
- 48995 for all Series 50 Models AG054A-().

Specify the required kit number for the appropriate series / model tool from the chart below.

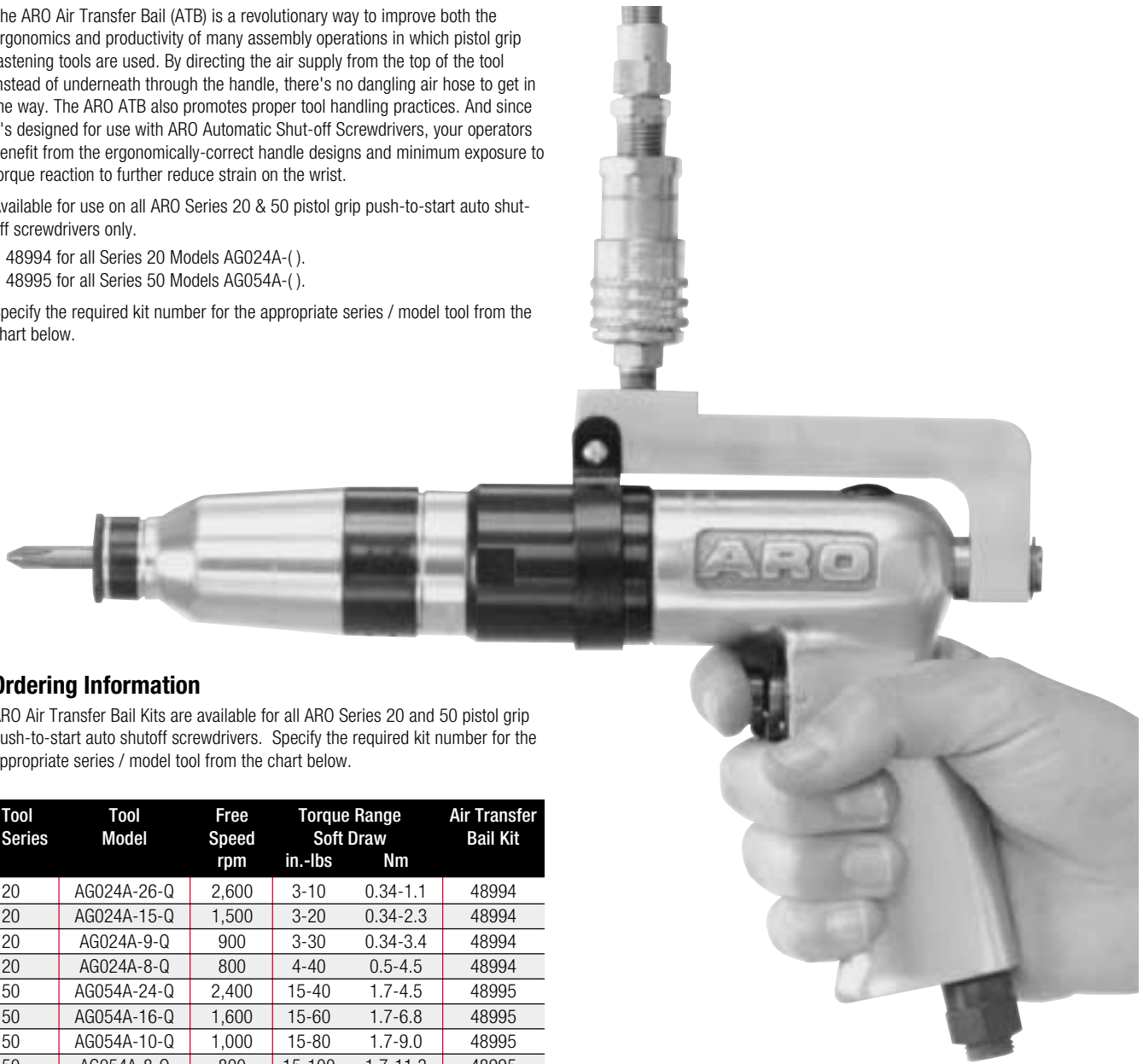

### Ordering Information

ARO Air Transfer Bail Kits are available for all ARO Series 20 and 50 pistol grip push-to-start auto shutoff screwdrivers. Specify the required kit number for the appropriate series / model tool from the chart below.

Tool Series	Tool Model	Free Speed rpm	Torque Range		Air Transfer Bail Kit
			Soft Draw in.-lbs	Nm	
20	AG024A-26-Q	2,600	3-10	0.34-1.1	48994
20	AG024A-15-Q	1,500	3-20	0.34-2.3	48994
20	AG024A-9-Q	900	3-30	0.34-3.4	48994
20	AG024A-8-Q	800	4-40	0.5-4.5	48994
50	AG054A-24-Q	2,400	15-40	1.7-4.5	48995
50	AG054A-16-Q	1,600	15-60	1.7-6.8	48995
50	AG054A-10-Q	1,000	15-80	1.7-9.0	48995
50	AG054A-8-Q	800	15-100	1.7-11.3	48995

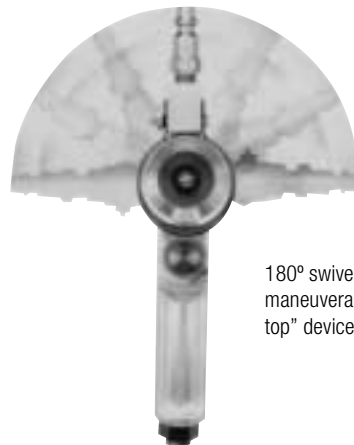
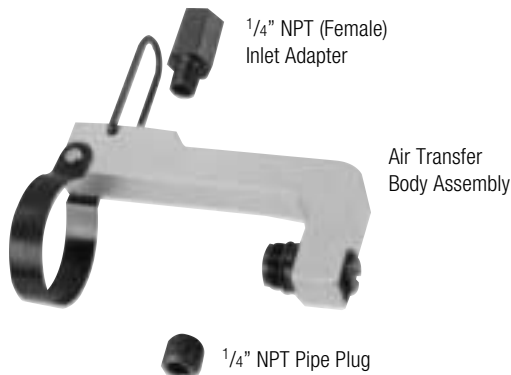

180° swivel action provides greater maneuverability than the other "air on top" device.

**Improve operator comfort and productivity!**

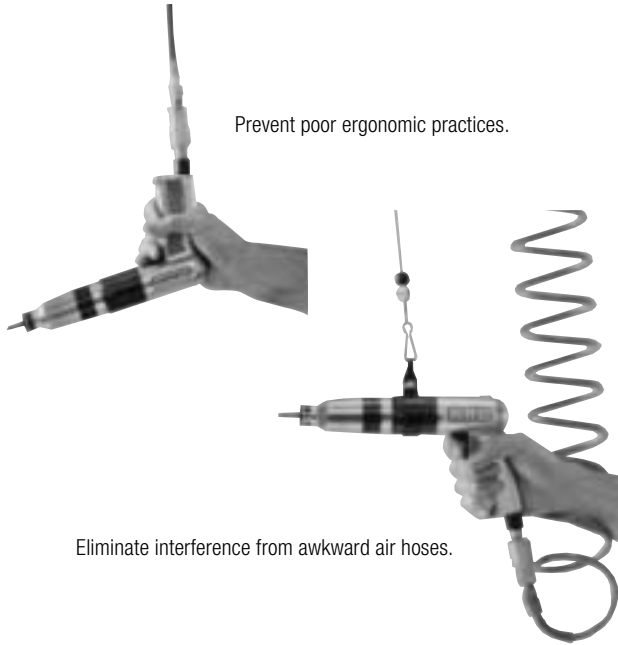

Prevent poor ergonomic practices.

Eliminate interference from awkward air hoses.



46467<sup>1</sup>  
47795<sup>2</sup>



46328

- (1) Use on Series 50 with No. 46467 ring gear.
  - (2) Use on Series 41 with No. 48904 ring gear.
- See side notes.



**Ingersoll-Rand IRAX Hose Reel Balancer**



ARO Series 20 or 50 Pistol Grip, Push-To-Start Screwdriver

ARO Air Transfer Ball

The Ingersoll-Rand IRAX Hose Reel Balancers are a convenient combination of a tool balancer and an air supply. There's no need for a separate suspension balancer and yoke. Hose tension is easily adjustable to match the weight of the tool used.

- BHR15 1<sup>1</sup>/<sub>2</sub> – 3<sup>1</sup>/<sub>3</sub> lbs load capacity, 4<sup>1</sup>/<sub>4</sub> ft. of lift
- BHR25 2<sup>5</sup>/<sub>8</sub> – 5<sup>1</sup>/<sub>2</sub> lbs load capacity, 4<sup>1</sup>/<sub>4</sub> ft. of lift

**Suspension Bails**

Bails are used to position tools above the immediate work area within easy reach of the operators. They are effective in minimizing the physical effort and time required to handle tools.

- 47795 for Series 20 pistol grip and right angle models.
- 46472 for Series 50 pistol grip and right angle models. Not with ASOs and some ball clutch tools.
- 46328 for Series 20 and 50 in-line model (included as standard equipment with each tool).
- 48934 for IR Series 41 and ARO ASO pistol grip tool and some ball clutch tools.

**Balancers**

Balancers can be used to suspend a tool from a workstation jib arm or from an overhead fixture. An external adjustment permits matching the extension to the weight of the tool, virtually eliminating the weight of the tool from the operator to reduce fatigue.

- 8375-2, 2 lbs (.9 kg) capacity, equipped with 5 ft. of cable.
- 8375-4, 4 lbs (1.5 kg) capacity, equipped with 5 ft. cable.
- 7472, 5 lbs (2.3 kg) capacity, equipped with 8 ft. cable.

# Industrial Tool Accessories

## Assembly Tools

### Custom Covers

The ARO Custom Cover Tool Wraps are yet another ergonomic advantage of ARO Tool and Hoist Products. Made of a unique engineered foam material, Custom Covers have been proven effective in minimizing the effects of tool vibration. The textured finish and insulating properties provide a comfortable, warm-to-the-touch grip surface, requiring less gripping force, for improved handling and less fatigue. And unlike many other tool wraps, ARO Custom Covers contain no mercury, eliminating concerns about possible worker exposure and environmental issues over proper disposal. They're die cut for a perfect fit and are available for many of the most popular ARO air tools.



### Features and Benefits

- Effective vibration damping
- Comfortable, non-slip grip surface
- Die cut for perfect fit
- Also available in sheet form
- No-mess self-adhesive backing

### Ordering Information

ARO Custom Cover Kits are available for the following ARO air tools. See chart below.

Tool Model	Description	Kit No.
DG021B-(-)-(-)	Series 20 P.G. Drill	49040-13
DG022B-(-)-(-)	Series 20 P.G. Drill	
DG051B-(-)-(-)	Series 50 P.G. Drill	
DG052B-(-)-(-)	Series 50 P.G. Drill	
SG021B-(-)-(-)	Series 20 P.G. Screwdriver	49040-13
SG022B-(-)-(-)	Series 20 P.G. Screwdriver	
SG023B-(-)-(-)	Series 20 P.G. Screwdriver	
SG029B-(-)-(-)	Series 20 P.G. Screwdriver	
SG051B-(-)-(-)	Series 50 P.G. Screwdriver	
SG052B-(-)-(-)	Series 50 P.G. Screwdriver	
SG053B-(-)-(-)	Series 50 P.G. Screwdriver	
SG059B-(-)-(-)	Series 50 P.G. Screwdriver	
AG024A-(-)-(-)	Series 20 P.G. Screwdriver	
AG027A-(-)-(-)	Series 20 P.G. Screwdriver	
AG028A-(-)-(-)	Series 20 P.G. Screwdriver	49040-18 <sup>1</sup>
AG054A-(-)-(-)	Series 50 P.G. Screwdriver	
AG057A-(-)-(-)	Series 50 P.G. Screwdriver	
AG058A-(-)-(-)	Series 50 P.G. Screwdriver	
-	Other Tool Models	

(1) Kit includes one (1) 5 1/2" x 8 1/2" sheet of wrap material and seam tape which can be cut to fit a variety of power tools.

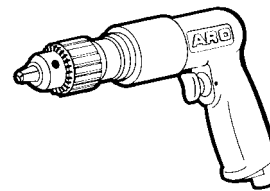

Series 20/50 Pistol Grip Drill

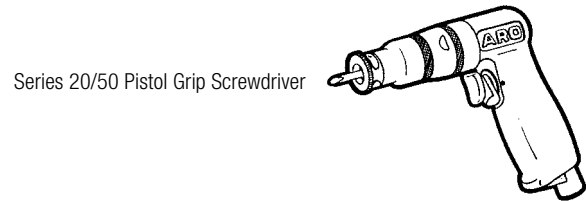

Series 20/50 Pistol Grip Screwdriver

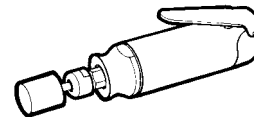

Die Grinder

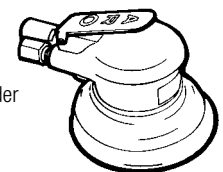

Random Orbital Sander

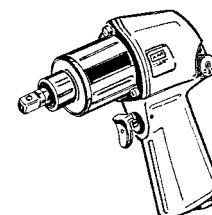

Impact Wrench





47618 Bio-Grip

47822 Bio-Mechanical Flange



46724 Rubber Grip

### Grips and Flanges

Rubber grip and plastic bio-grip provide a more comfortable surface to hold. Bio-grip and bio-mechanical flange reduce the amount of gripping pressure required to hold a tool when applying downward force.

- 47618 Bio-Grip for all Series 20 in-line models.
- 47822 Bio-Mechanical Flange for all Series 50 in-line models.
- 49040-13 Custom Cover™ Tool Wrap for all Series 20 & 50 pistol grip models.

Note: Grips and Flanges cannot be used on models with Skinsulate™. Consult factory.



46831 Side Handle

### Side Handle

Using a Side Handle on a straight/lever throttle screwdriver or drill reduces the amount of pressure required to grip a tool when applying downward force. On a pistol grip tool it enables the operator to apply added pressure to the screwdriver or drill bit and maintain proper wrist positioning. It also helps to effectively minimize the strain on the wrist from reaction torque, especially in higher torque applications.

- 46831 Side Handle for all Series 50 models.

Note: Recommended for use on all Series 50 auto shutoff and adjustable clutch screwdrivers. No extra cost when ordered with tool.

- 48931 Side Handle for IR Series 41



### Swivel Fitting

An ARO Swivel Fitting reduces the amount of effort and strain often required to maneuver a tool by minimizing the "drag" caused by the air hose. Air flow can also be regulated from 0 to 25 cfm by the external adjustment knob.

Swivel	Thread Size	Weight	Recommended Air Flow	Pressure Range
ASA 1/4	1/4" NPT	3 oz.	Up to 25 cfm	0-150 psi
ASA 3/8	3/8" NPT	3 oz.	Up to 25 cfm	0-150 psi

# Industrial Tool Accessories

## Assembly Tools

### Piped Exhaust Assemblies

An ARO Piped Exhaust System is an effective method to help keep dirt and oil contaminants out of the work area while reducing operating sound levels. Each system comes complete with air inlet and exhaust hoses, all necessary fittings and adapters, and a muffler.

Piped Exhaust No.	Tool Model / Series Used On	Length
44360-(-)	Model 7014 & 7015 Grinders	(1)
	Model 8317 & 8318 Grinders	
	Model 8299 Screwdrivers & Nutsetters	
	Models 7456 & 7453 Nutsetters for all random orbital sanders	
44361-(-)	Models 8506, 8509, 8515, 8521	(1)
	QRT Screwdrivers	
44561-(-)	Models 7840, 7843 Grinders	(1)
	Models 7874, 8067 Grinders	
	Models 7939, 7944, 7945 Sanders	
	Models 784X, 785X Drills	
	Models 785X, 786X, 788X, 789X Screwdrivers	
	Model 8038, 8039, 8040 Electrode Dressers	

(1) Add dash number to Piped Exhaust No. to indicate the desired length in feet.



### Overhose Assemblies

An ARO Overhose Assembly is a simple, economical means to deflect tool exhaust away from the immediate work area. It reduces operating sound levels and helps keep dirt and oil out of the immediate work area.

Overhose <sup>1</sup> No.	Tool Model / Series Used On	Standard Length	
		ft	m
46373 <sup>2</sup>	Series 20 Straight Screwdrivers & Drills	2	0.6
46490 <sup>2</sup>	Series 20 Pistol Grip Screwdrivers & Drills	2	0.6
-	All Series 50 Screwdrivers & Drills	-	-

(1) Add dash number to Overhose No. to indicate the desired length in feet.

(2) Use 46513 Clamp to secure 46373 hose and use 46477 Clamp to secure 46490 hose to straight tools. Order separately.

# Warranty Information

---

ARO provides three different product warranties. Each warranty is designed to give you the maximum coverage and protection for your ARO products. Check the warranty card(s) provided with your ARO tool(s) for the appropriate warranty information.

The following information outlines the three basic warranties provided by ARO and the products they cover.

## One-Year Warranty

Products Covered: All products (except automatic shutoff tools-see below)

## Two-Year Warranty

Products Covered: Random Orbital Sanders.

## Warranty Statement

ARO Tool Products warrants the original user of the Product (Tool) to be free of defects in material and workmanship for a period of (one year, two years) from the date of purchase. ARO will repair, without cost, any Tool found to be defective, including parts and labor charges, or at its option, will replace such Tools or refund the purchase price less a reasonable allowance for depreciation in exchange for the Tool. Repairs or replacements are warranted for the remainder of the original warranty period.

If this Tool proves defective within its original (one year, two years) warranty period, it should be returned to any Authorized ARO Tool Distributor, transportation prepaid with proof of purchase or warranty card.

This warranty does not apply to Tools which ARO has determined to have been misused or abused, improperly maintained by the user, or where the malfunction or defect can be attributed to the use of non-genuine ARO repair parts.

ARO makes no other warranty, and ALL IMPLIED WARRANTIES INCLUDING ANY WARRANTY OF MERCHANTABILITY OR FITNESS FOR A PARTICULAR PURPOSE ARE LIMITED TO THE DURATION OF THE EXPRESSED WARRANTY PERIOD AS SET FORTH ABOVE. ARO's maximum liability is limited to the purchase price of the Tool and in no event shall ARO be liable for any consequential, indirect incidental, or special damages of any nature arising from the sale or use of the Tool, whether in contract, tort, or otherwise.

Note: Some states do not allow limitations on incidental or consequential damages or how long an implied warranty lasts so that the above limitations may not apply to you.

This warranty gives you specific legal rights and you may also have other rights which may vary from state to state.

## One/Five-Year Warranty

Products Covered: One Year — “20” and “50” series automatic shutoff tools.

Five Year — “20” and “50” series automatic shutoff clutch.

## Warranty Statement

ARO Tool Products warrants the original user of any ARO Series 20 and 50 automatic shutoff screwdriver and nutsetter, (Tool), to be free of defects in material and workmanship for a period of one year from the date of purchase, and with respect to the automatic shutoff clutch contained therein, five years from date of purchase. ARO will repair, without cost, any Tool found to be defective, including parts and labor charges, or at its option, will replace such Tools or refund the purchase price less a reasonable allowance for depreciation in exchange for the Tool. Repairs or replacements are warranted for the remainder of the original warranty period.

If this Tool proves defective within its original warranty period, it should be returned to any Authorized ARO Tool Distributor, transportation prepaid with proof of purchase or warranty card.

This warranty does not apply to Tools which ARO has determined to have been misused or abused, improperly maintained by the user, or where the malfunction or defect can be attributed to the use of non-genuine ARO repair parts.

ARO makes no other warranty, and ALL IMPLIED WARRANTIES INCLUDING ANY WARRANTY OF MERCHANTABILITY OR FITNESS FOR A PARTICULAR PURPOSE ARE LIMITED TO THE DURATION OF THE EXPRESSED WARRANTY PERIOD AS SET FORTH ABOVE. ARO's maximum liability is limited to the purchase price of the Tool and in no event shall ARO be liable for any consequential, indirect incidental, or special damages of any nature arising from the sale or use of the Tool, whether in contract, tort, or otherwise.

Note: Some states do not allow limitations on incidental or consequential damages or how long an implied warranty lasts so that the above limitations may not apply to you.

This warranty gives you specific legal rights and you may also have other rights which may vary from state to state.

Remember, to ensure that your ARO tool products are fully protected by our power tool warranties, registration cards must be filled out entirely at time of purchase and returned to ARO Tool Products.









# Warning Information

	<b>⚠ WARNING</b>
	Always wear eye protection when operating or performing maintenance on this tool.

	<b>⚠ WARNING</b>
	Always wear hearing protection when operating this tool.

	<b>⚠ WARNING</b>
	Always turn off the air supply and disconnect the air supply hose before installing, removing or adjusting any accessory on this tool, or before performing any maintenance on this tool.

	<b>⚠ WARNING</b>
	Air powered tools can vibrate in use. Vibration, repetitive motions or uncomfortable positions may be harmful to your hands and arms. Stop using any tool if discomfort, tingling feeling or pain occurs. Seek medical advice before resuming use.

	<b>⚠ WARNING</b>
	Do not carry the tool by the hose.

	<b>⚠ WARNING</b>
	Do not use damaged, frayed or deteriorated air hoses and fittings.

	<b>⚠ WARNING</b>
	Keep body stance balanced and firm. Do not overreach when operating this tool.

	<b>⚠ WARNING</b>
	Operate at 90 psig (6.2 bar / 620 kPa) maximum air pressure.

**Note: Always read the operators' manual before using any air tool.**

### In General...

- Always install, operate, inspect and maintain tools in accordance with American National Standards Institute Safety Code for Portable Air Tools (ANSI B186.1).
- Always use clean dry air at 90 psig (6.2 bar/620 kPa) maximum air pressure at the inlet. Higher pressure may result in hazardous situations, including excessive speed, rupture, or incorrect output torque or force.
- Air powered tools can vibrate in use. Vibration, repetitive motions or uncomfortable positions may be harmful to your hands and arms. Stop using any tool if discomfort, tingling feeling or pain occurs. Seek medical advice before resuming use.
- Always turn off the air supply and disconnect the air supply hose before installing, removing or adjusting any accessory on a tool, or before performing any maintenance on a tool.
- Keep hands, loose clothing, long hair and jewelry away from working end of tool.
- Keep body stance balanced and firm. Do not overreach when operating tool. Anticipate and be alert for sudden changes in motion, reaction torques, or forces during start up and operation.
- Tool and/or accessories may briefly continue their motion after throttle is released.
- Do not lubricate tools with flammable or volatile liquids such as kerosene, diesel, or jet fuel. Use only recommended lubricants.
- Do not remove any labels. Replace any damaged label.
- Use accessories recommended by ARO Tool Products.

# Contact Information

## When Using Grinders...

- Do not use tools if actual free speed exceeds the nameplate rpm.
- Tachometer to make certain its actual speed at 90 psig (6.2 bar/620 kPa) does not exceed the rpm stamped or printed on the name plate. Grinders in use on the job must be similarly checked at least once each shift.
- Always use the ARO wheel guard furnished with the grinder. Failure to do so could result in injury.
- Do not use a grinder without the recommended wheel guard. Do not use any wheel for which the operating speed listed on the blotter is lower than the actual free speed of the grinder.
- Inspect all grinding wheels for chips or cracks prior to mounting. Do not use a wheel that is chipped or cracked or otherwise damaged. Do not use a wheel that has been soaked in water or any other liquid.
- Make certain the grinding wheel properly fits the arbor. The wheel should not fit too snugly or too loosely. Plain hole wheels should have about 0.007" (0.17mm) maximum diametral clearance. Do not use reducing bushings to adapt a wheel to any arbor unless such bushings are supplied by or recommended by the wheel manufacturer.
- After mounting a new wheel, hold the grinder under a steel workbench or inside a casting and run it for at least 60 seconds. Make certain no one is within the operating plane of the grinding wheel. If the wheel is defective, improperly mounted or the wrong size and speed, this is the time it will usually fail.
- When starting a cold wheel, apply it to the work slowly until the wheel gradually warms up. Make smooth contact with the work, and avoid any bumping action or excessive pressure.
- Always replace a damaged, bent or severely worn wheel guard. Do not use a wheel guard that has been subjected to a wheel failure.
- Make certain the wheel flanges are at least  $\frac{1}{3}$  the diameter of the grinding wheel, free of nicks and burrs and sharp edges. Always use the wheel flanges furnished by the manufacturer; never use a makeshift flange or a plain washer.
- Guard opening must face away from operator. Bottom of wheel must not project beyond guard.
- Always use a wheel blotter between each wheel flange and the wheel. The blotters must be at least as large in diameter as the wheel flanges.
- Do not attempt to disassemble the controller. The controller is available only as a unit and is guaranteed for the life of the tool if it is not abused.

## For Sales Information . . .

### United States

**Ingersoll-Rand  
Productivity Solutions Headquarters**  
1467 Route 31 South,  
Annandale, NJ 08801  
Telephone: (908) 238-7000  
Fax: (908) 238-7052

**ARO Tool Products**  
1725 U.S. Hwy 1 North, P.O. Box 8000  
Southern Pines, NC 28387  
Telephone: (910) 632-8700  
Fax: (910) 692-7822

### Distribution Center

**Ingersoll-Rand/ARO Tool Products**  
510 Hester Drive,  
White House, TN 37188  
Telephone: (615) 672-0321  
Fax: (615) 672-7555

### Detroit/Metro Regional Office

**Ingersoll-Rand Tool and  
Hoist Division**  
23192 Commerce Drive,  
Farmington Hills, MI 48335  
Telephone: (248) 476-6677  
Fax: (248) 476-6670

### Canada

**Production Equipment Group**  
Ingersoll-Rand/ARO Canada Inc.  
51 Worcester Road, Toronto,  
Ontario M6W 4K2  
Telephone: (416) 213-4500  
Fax: (416) 213-4510

### Regional Office

**Ingersoll-Rand/ARO Canada Inc.**  
1430-5555 Calgary Trail, N.W.,  
Edmonton, Alberta T6H 5P9  
Telephone: (403) 438-5039  
Fax: (403) 437-3145

### Regional Office

**Ingersoll-Rand/ARO Canada Inc.**  
3501 St. Charles Blvd.  
Kirkland, Quebec H9H 4S3  
Telephone: (514) 695-9040  
Fax: (514) 695-0963

**Ingersoll-Rand/ARO Canada Inc.**  
201-6351 Westminster Highway  
Richmond, B.C. V7C 5C7  
Telephone: (604) 274-0459  
Fax: (604) 654-1706

### International

#### Latin America

**Ingersoll-Rand/ARO Tool Products**  
730 N.W. 107th Ave., Suite 300  
Miami, FL 33172-3107  
Telephone: (305) 559-0500  
Fax: (305) 222-0864

**Ingersoll-Rand Company  
Production Equipment Group**  
Centro Profesional Eurobuilding  
Piso 6, Oficina 6-B  
Chua, Caracas, Venezuela  
Telephone: (582) 92-47-37  
Telephone: (582) 92-75-53  
Fax: (582) 99-39-276

#### Europe / Middle East / Africa

**Ingersoll-Rand Sales Company, Ltd.  
ARO Tool Products**  
Swan Lane  
Hindley Green, Wigan  
Lancashire WN2 4EZ, United Kingdom  
Telephone: 44-(1) 942 257131  
Fax: 44-(1) 942 526255

#### Asia / Pacific

**Ingersoll-Rand Asia Pacific Ltd.  
Production Equipment Group**  
Suite 1201-03, 12/Floor  
Central Plaza, 18 Harbour Road  
Wanchai, Hong Kong  
Telephone: (852) 2527-0183  
Fax: (852) 2592-5976



**Toll-Free 1-866-763-6226 Phone: 905-672-5557  
Fax: 905-672-5559 Email: sales@dobcoeqp.com**



**IR** ARO®

**DOBCO** EQUIPMENT LTD. Toll-Free 1-866-763-6226 Phone: 905-672-5557  
Fax: 905-672-5559 Email: [sales@dobcoeqp.com](mailto:sales@dobcoeqp.com)